

***Modelling the Transfer
of Radionuclides from
Naturally Occurring
Radioactive Material
(NORM)***

***Report of the NORM Working Group
of EMRAS Theme 3***

***Environmental Modelling for
RAdition Safety (EMRAS) Programme***

FOREWORD

Environmental assessment models are used for evaluating the radiological impact of actual and potential releases of radionuclides to the environment. They are essential tools for use in the regulatory control of routine discharges to the environment and also in planning measures to be taken in the event of accidental releases; they are also used for predicting the impact of releases which may occur far into the future, for example, from underground radioactive waste repositories. It is important to check, to the extent possible, the reliability of the predictions of such models by comparison with measured values in the environment or by comparing with the predictions of other models.

The International Atomic Energy Agency (IAEA) has been organizing programmes of international model testing since the 1980s. The programmes have contributed to a general improvement in models, in transfer data and in the capabilities of modellers in Member States. The documents published by the IAEA on this subject in the last two decades demonstrate the comprehensive nature of the programmes and record the associated advances which have been made.

From 2002 to 2007, the IAEA organised a programme titled “Environmental Modelling for Radiation Safety” (EMRAS). The programme comprised three themes:

Theme 1: Radioactive Release Assessment

Working Group on the revision of IAEA Handbook of parameter values for the prediction of radionuclide transfer in temperate environments (Technical Reports Series (TRS) 364).

Working Group on model testing related to countermeasures applied to the intake of iodine-131 from the Chernobyl accident.

Working Group on testing of models for the environmental behaviour of tritium and carbon-14 following routine and accidental releases.

Working Group on testing of models for predicting the behaviour of radionuclides in freshwater systems and coastal areas.

Theme 2: Remediation Assessment

Working Group on testing of models for the remediation of the urban environment.

Working Group on modelling the transfer of radionuclides from naturally occurring radioactive material (NORM).

Theme 3: Protection of the Environment

Working Group on the review of data and testing of models for predicting the transfer of radionuclides to non-human biological species.

This report describes the work of the NORM Working Group under Theme 2. The IAEA wishes to acknowledge the contribution of the Working Group Leader, R. O’Brian of Australia, to the preparation of this report. The IAEA Scientific Secretary for this publication was P. Waggitt of the Division of Radiation, Transport and Waste Safety.

CONTENTS

SUMMARY	1
CHAPTER 1. INTRODUCTION	3
1.1. Background	3
1.1.1. Ubiquity of NORM	5
1.1.2. Waste or residue issues	5
1.1.3. Awareness issues	5
1.1.4. Inconsistencies in international standards	6
1.1.5. Previous work	6
1.2. NORM industries	7
1.3. Types of assessment involving NORM wastes and residues	8
1.3.1. Regulatory	8
1.3.2. Operational monitoring	8
1.3.3. Retrospective – legacy wastes and residues from past practices	8
1.3.4. Exposure situations/scenarios	9
1.4. Current trends in NORM residue management	10
1.5. Objectives	10
1.6. Scope	11
1.7. Structure of this report	12
CHAPTER 2. MODELLING	13
2.1. Overview of current status of international experience	13
2.2. Models and Their Uses	13
2.2.1. Screening models	14
2.2.2. Compliance models	14
2.2.3. Detailed impact assessment models	14
2.3. Models used in this work	14
2.4. Model Descriptions	14
2.5. Model Documentation	14
2.6. Use of Models to Develop Screening Dose and Risk Lookup Tables and Graphs	15
CHAPTER 3. SCENARIOS	16
3.1. Overview and rationale	16
3.2. Legacy sites	16
3.2.1. Contaminated urban areas	16
3.2.2. Remediation actions	16
3.2.3. Difficulties with remediation of legacy sites	16
3.3. Hypothetical scenarios	17
3.3.1. Point source	17
3.3.2. Area source	17
3.3.3. Area source plus river	17
3.4. Real Scenarios	18
3.4.1. Lignite power plant (LPP II) scenario	18
3.4.2. Former gas mantle production plant (Camden) scenario	18
3.4.3. Phosphogypsum disposal site (PGDS1)	18
3.4.4. Phosphogypsum disposal site (PGDS2)	18

CHAPTER 4.	TESTING OF HYPOTHETICAL SCENARIOS	20
4.1.	Point source.....	20
4.1.1.	COMPLY/CAP-88	20
4.1.2.	PC-CREAM.....	20
4.1.3.	Comparison of results	20
4.2.	Area source	21
4.2.1.	DOSDIM + HYDRUS.....	21
4.2.2.	RESRAD (Version 6.2)	21
4.2.3.	RESRAD-OFFSITE	22
4.2.4.	Comparison of results from different models.....	22
CHAPTER 5.	TESTING OF REAL SCENARIOS	23
5.1.	Lignite power plant (LPP II) Scenario.....	23
5.1.1.	PC-CREAM calculations.....	23
5.1.2.	COMPLY calculations.....	23
5.1.3.	CROM calculations	23
5.1.4.	Comparison of results	23
5.2.	Former gas mantle production plant (Camden) scenario.....	23
5.3.	Phosphogypsum stack – PGDS1	23
5.4.	Phosphogypsum stack – PGDS2.....	23
CHAPTER 6.	DISCUSSION	24
CHAPTER 7.	RECOMMENDATIONS	26
7.1.	Suitability of models	26
7.2.	Pitfalls in using models.....	26
7.2.1.	Conceptual model assumptions	26
7.2.2.	Misuse of models.....	26
7.2.3.	Training.....	27
7.2.4.	Ease of use	27
7.2.5.	Data sets for model testing	27
7.2.6.	Guidance on use of models.....	27
7.3.	The overall assessment process	27
7.3.1.	Importance of communication.....	28
7.4.	Follow-up of this work.....	28
APPENDIX I.	DESCRIPTION OF NORM INDUSTRIES	29
I.1.	Extraction and processing of mineral sands.....	29
I.1.1.	Niobium and ferro-niobium production.....	29
I.1.2.	Manufacture of rare earths.....	30
I.1.3.	Titanium dioxide pigment industry	30
I.2.	Metal mining and smelting	30
I.2.1.	Tin mining and processing.....	30
I.2.2.	Bauxite processing (aluminium production)	31
I.2.3.	Copper refining.....	31
I.2.4.	Iron and steel production	31
I.3.	Zircon production.....	32

I.4.	Phosphate industry	32
I.4.1.	Mining and milling of phosphate ore.....	33
I.4.2.	Phosphate ore: wet process.....	33
I.4.3.	Phosphate ore: thermal process	33
I.4.4.	Fertilisers, and biosolids from wastewater treatment	33
I.5.	Coal mining and power production from coal	34
I.6.	Oil and gas extraction industry	34
I.7.	Natural gas production.....	35
I.8.	Disposal of building materials	35
I.9.	Applications of radium and thorium.....	35
I.10.	Manufacture and applications of thorium compounds.....	35
APPENDIX II.	MODELS	36
II.1.	Models used in this work	36
II.1.1.	COMPLY.....	36
II.1.2.	CAP88.....	36
II.1.3.	PC-CREAM.....	37
II.1.4.	CROM.....	37
II.1.5.	RESRAD (onsite)	37
II.1.6.	RESRAD-OFFSITE	39
II.1.7.	DOSDIM + HYDRUS.....	45
II.1.8.	PRESTO-CPG ver. 4.2	45
II.1.9.	AMBER	46
II.2.	Other models.....	46
II.2.1.	RESRAD-BUILD	46
II.2.2.	FRAMES	47
II.2.3.	GENII	48
II.2.4.	ROOM	49
II.2.5.	MILDOS	49
II.2.6.	MICROSHIELD	49
II.3.	Screening Models.....	49
II.3.1.	Soil Screening Guidance for Radionuclides	49
II.3.2.	Preliminary Remediation Goals for Radionuclides	50
II.3.3.	RCLEA	50
II.3.4.	BPRG.....	51
APPENDIX III.	SPECIFICATIONS FOR THE HYPOTHETICAL SCENARIOS	52
III.1.	Guidance for modellers.....	52
III.2.	Hypothetical point source scenario.....	52
III.2.1.	Site Description	52
III.2.2.	Data tables and figures for hypothetical point source scenario	53
III.3.	Hypothetical area source scenario	55
III.3.1.	Site Description	55
III.3.2.	Data.....	55
III.3.3.	Data tables and figures for hypothetical area source scenario.....	57
III.4.	Hypothetical area source + river scenario.....	62
III.4.1.	Site Description	62
III.5.	Data tables and figures for hypothetical area source + river scenario	63

APPENDIX IV.	TESTING OF HYPOTHETICAL POINT SOURCE SCENARIO	64
IV.1.	COMPLY, CAP-88.....	64
IV.1.1.	Introduction.....	64
IV.1.2.	Point Scenario – Scenario Description	64
IV.1.3.	Default data for the COMPLY model	65
IV.1.4.	Results.....	65
IV.2.	PC-CREAM.....	67
IV.2.1.	Methodology used with PC-CREAM.....	67
IV.2.2.	PC-CREAM Results	68
IV.2.3.	CROM results	70
APPENDIX V.	TESTING OF THE HYPOTHETICAL AREA SOURCE SCENARIO	73
V.1.	DOSDIM and HYDRUS.....	73
V.1.1.	Methodology used with DOSDIM and HYDRUS	73
V.1.2.	Exposure pathways to be considered.....	73
V.1.3.	Modelling of the ²²² Rn concentrations in the air due to exhalation from the waste.....	77
V.1.4.	External irradiation from the waste and inhalation of resuspended dust.....	80
V.1.5.	Calculation of water concentration in the aquifer.....	81
V.1.6.	Calculation of dose impact due to water and food ingestion.....	81
V.1.7.	Dealing with decay chains in the biosphere model	84
V.1.8.	Calculating the activity of daughter nuclides with intermediate half-lives	85
V.1.9.	Results – concentrations of radionuclides in environmental media.....	87
V.1.10.	Results – Annual Doses (Sv a ⁻¹).....	90
V.1.11.	Concluding Tables/Graphs	92
V.2.	RESRAD (onsite), RESRAD-OFFSITE.....	96
V.2.1.	RESRAD (onsite)	96
V.2.2.	RESRAD-OFFSITE	97
V.2.3.	Summary for House #2.....	102
V.2.4.	RESRAD-OFFSITE results for House #3	103
V.2.5.	PRESTO	104
APPENDIX VI.	TESTING OF HYPOTHETICAL AREA SOURCE PLUS RIVER SCENARIO	109
VI.1.	RESRAD-OFFSITE.....	109
VI.1.1.	Results for house #1.....	109
VI.1.2.	Results for house #2.....	113
APPENDIX VII.	DESCRIPTION OF REAL SCENARIOS.....	115
VII.1.	Lignite power plant (LPP II).....	115
VII.1.1.	Power plant description	115
VII.1.2.	Dust deposition	116
VII.1.3.	Meteorological data	116
VII.1.4.	Sample collection.....	117
VII.1.5.	Dietary Consumption.....	118
VII.1.6.	Further information.....	118

VII.2.	Phosphogypsum stack scenario (PGDS1).....	119
VII.2.1.	Basic figures and tables for PGDS1	119
VII.3.	Phosphogypsum stack scenario (PGDS2).....	125
APPENDIX VIII.	Testing Of Real Scenarios	128
VIII.1.	Power Plant Scenario – LPPII.....	128
VIII.1.1.	LPPII scenario summarised.....	128
VIII.1.2.	PC-CREAM calculations	128
VIII.1.3.	COMPLY calculations	135
VIII.1.4.	CROM calculations	136
APPENDIX IX.	DEVELOPMENT OF LOOKUP TABLES AND GRAPHS TO EVALUATE GENERIC RADIATION RISKS	138
IX.1.	On-Site Recreation.....	138
IX.2.	Use of Uranium Mine Waste in Building Materials	141
REFERENCES.....		143
BIBLIOGRAPHY		149
LIST OF PARTICIPANTS		161

SUMMARY

This working group was established to improve the modelling of the transfer of radionuclides from residues containing naturally occurring radioactive material (NORM) for the purposes of radiological assessment.

Almost all naturally occurring materials contain radionuclides from the primordial decay chains (for example, uranium-238, uranium-235, thorium-232 and their daughter products radium-226 and radium-228), plus some individual long-lived radionuclides such as potassium-40. Extraction and/or processing of minerals containing these materials results waste containing such radionuclides. Often the processing can enhance the concentration of the NORM in the waste as compared with the original material. The extraction and processing of minerals usually involves large volumes of material and the resulting waste is also present in large volumes which are usually left on the earth's surface. Human exposure to radionuclides from such waste piles can occur as a result of gaseous emanation from the waste (radon-222) or as a result of the leaching by rainfall of radionuclides from the waste into water courses and, possibly, food chains.

There are a variety of situations involving NORM that require potential radiation doses to be assessed, they include:

- (1) surface storage of residues from the extraction and processing of minerals;
- (2) remediation of NORM-containing waste piles; and
- (3) the use of NORM-containing waste for backfilling, building materials, road construction etc.

In all of these situations there is a need to understand the present and future behaviour of the radionuclides which may be released from NORM so that steps can be taken to ensure that humans are adequately protected from exposure to radiation. Because of the long-lived nature of many of the radionuclides, the assessments must be carried out over long times into the future.

This is the first time that the modelling of NORM-containing radionuclides has been examined in this IAEA format and the working group spent much of its time exploring the global situation and determining the availability of modelling tools.

In contrast with other EMRAS working groups, the participants of the NORM working group generally chose to apply existing models from the literature to the test scenarios. These models had been developed by other organizations and so the participants were usually model **users** rather than model **developers/users**, as was the case in most of the other working groups. For these reasons, the issue of 'ease of use' of the models was an important issue for the working group. It was noted that several of the models examined were not very 'user friendly' with insufficient explanation provided for the user. It was concluded that ease of use could be greatly enhanced by the provision of good documentation and 'help screens', databases containing default values of environmental parameters, and facilities for plotting the results of calculations. It is also extremely important to provide the model user with simple procedures for changing the default values and for adding extra data to existing databases.

Predictions were made for the three hypothetical scenarios using several models. The results for the point source scenario showed that the simple models (COMPLY, CROM) predicted higher radionuclide concentrations than the more realistic model PC-CREAM.

Predictions were made for the area source scenario using two models (RESRAD-OFFSITE and DOSDIM + HYDRUS). In general, the results obtained from the two models (which use different methodologies for groundwater transport) were consistent with each other. RESRAD was “calibrated” by estimating the natural background radiation level and comparing it to the existing natural background radiation levels.

The limited amount of model testing which was conducted within the working group does not allow proper conclusions to be drawn about the state of modelling in this area. It is clear that more model testing, especially using the real scenarios, is needed and that specific model components and techniques may need to be developed to allow some of the more complex features of the real scenarios to be modelled.

This is a subject of importance for many countries and for them competence in predicting the behaviour of radionuclides in situations involving NORM needs to be developed.

CHAPTER 1. INTRODUCTION

The EMRAS (Environmental Modelling for Radiation Safety) project was set up to continue the work begun on environmental modelling in the BIOMOVs, VAMP and BIOMASS projects, and to look at some areas of environmental modelling that were not covered in detail in those earlier projects. The earlier projects concentrated mostly on anthropogenic radionuclides generated as part of the nuclear fuel cycle, such as tritium (^3H), radio-iodine (^{131}I) and radionuclides such as carbon-14 (^{14}C) and caesium-137 (^{137}Cs).

For the EMRAS project a working group was established to update the IAEA document TRS-364 [1], and other groups were set up to look at modelling of tritium, iodine, carbon-14, aquatic environments, urban remediation, naturally occurring radioactive material (NORM), and biota. This report describes the work carried out by the NORM working group.

There are many models already available. However, guidance on how and when to apply specific models is lacking in many cases. Development of models has often been carried out without a clear understanding of the possible applications of the models. Some models have been developed only for specific applications in specific industries, and are not generally useful.

There is no consistent approach to modelling requirements. Most models can calculate/predict concentrations and/or doses. However, there is no “standard” approach as to which outputs are required, or on guidance documentation, and verification and validation reporting.

1.1. Background

Many products, wastes and residues contain radionuclides which occur in the natural environment. These materials are collectively known as NORM. The radionuclides include the members of the primordial decay chains resulting from the decay of uranium-238 (^{238}U), uranium-235 (^{235}U) and thorium-232 (^{232}Th), and single extremely long-lived (primordial) radionuclides such as potassium-40 (^{40}K), indium-117 (^{117}In), and rubidium-87 (^{87}Rb). In the case of the primordial decay chains, the first member of each chain has an extremely long half-life (10^8 years or longer).

In the case of ^{40}K , homeostatic processes tend to keep the concentration within the body at a constant level. Therefore changes in the environmental concentration of ^{40}K do not usually have a significant impact on the total dose delivered to humans. Most of the other single primordial radionuclides occur in very low concentrations and have little radiological impact.

There are also some radionuclides that occur in the atmosphere as the result of collisions between cosmic rays and atmospheric atoms (spallation). These include tritium (^3H), beryllium-7 (^7Be) and carbon-14 (^{14}C). These radionuclides are outside the scope of this work.

The primordial decay series are summarised in Table 1.1. This table highlights the features of NORM that distinguish the study and assessment of the impact of NORM on human health and the environment from that of anthropogenic radionuclides. These features are:

- a large number of radionuclides and hence a wide range of chemical properties;
- an extremely wide range of radioactive half-lives; and
- a range of physical forms.

Table 1.1. The primordial radioactive decay series.

²³⁸ U series		²³⁵ U series		²³² Th series	
Nuclide	Half-life	Nuclide	Half-life	Nuclide	Half-life
²³⁸ U	4.51×10 ⁹ a	²³⁵ U	7.1×10 ⁸ a	²³² Th	1.41×10 ¹⁰ a
↓		↓		↓	
²³⁴ Th	24.1 d	²³¹ Th	25.6 h	²²⁸ Ra	5.8 a
↓		↓		↓	
²³⁴ Pa	1.17 min	²³¹ Pa	3.4 ×10 ⁴ a	²²⁸ Ac	6.13 h
↓		↓		↓	
²³⁴ U	2.47×10 ⁵ a	²²⁷ Ac	21.6 a	²²⁸ Th	1.910 a
↓		↓		↓	
²³⁰ Th	8.0×10 ⁴ a	²²⁷ Th	18.6 d	²²⁴ Ra	3.64 d
↓		↓		↓	
²²⁶ Ra	1602 a	²²³ Ra	11.7 d	²²⁰ Rn	55 s
↓		↓		↓	
²²² Rn	3.823 d	²¹⁹ Rn	3.9 s	²¹⁶ Po	0.15 s
↓		↓		↓	
²¹⁸ Po	3.05 min	²¹⁵ Po	1.8×10 ⁻³ s	²¹² Pb	10.64 h
↓		↓		↓	
²¹⁴ Pb		²¹¹ Pb	36 min	²¹² Bi	60.6 min
↓		↓		↓	
²¹⁴ Bi	19.7 min	²¹¹ Bi	2.2 min	²⁰⁸ Pb	Stable
↓		↓			
²¹⁰ Pb	21 a	²¹¹ Pb	0.5 s		
↓		↓			
²¹⁰ Bi	5.01 d	²⁰⁷ Pb	Stable		
↓					
²¹⁰ Po	138.4 d				
↓					
²⁰⁶ Pb	Stable				

The wide range of chemical properties, particularly solubility, can have a major effect on the behaviour of mixtures of these radionuclides in the environment, and hence on the number of potential exposure pathways. It should be noted, however, that in many situations this behaviour is controlled by the properties of the matrix (the material containing the radionuclides), particularly when this matrix material is extremely insoluble.

The wide range of half-lives is also very important. In addition, some of the radionuclides are gaseous (radon) and some are volatile (polonium, lead).

In the absence of processes such as dissolution, gaseous diffusion or volatilisation, the members of the decay chains will be in approximate secular equilibrium with the parent radionuclide. However, in many situations the effect of these processes is to selectively remove some radionuclides (for example water can dissolve the isotopes of radium, and polonium isotopes can be volatilised during mineral smelting) from the point of origin and introduce disequilibrium within the decay chain(s).

A consequence of this is that atmospheric dispersion (short-term) has to be considered as well as surface water transport (short-term to medium-term) and groundwater transport (long-term) when assessing the potential impact of NORM on the environment and on human health.

NORM gives rise to the largest collective doses to the global population [2], and is therefore important from a radiological perspective.

There are several additional factors which distinguish the NORM issue from other contamination situations involving radionuclides:

- re-use of materials (large volumes);
- exposure situations may involve materials with radionuclides in their natural state, or radionuclides which have been concentrated as a result of human actions;
- materials with small volumes of highly concentrated radionuclides, and large volumes of materials with low levels of radiation;
- projected land use (large tracts of land are used to store NORM residues);
- regulatory issues – emphasis is shifting from limitation to optimisation and acceptable risk;
- uranium ore is a mineral which is exploited specifically for its radionuclide content. However, other minerals which give rise to NORM residues and products are exploited for entirely different reasons, and the presence of radionuclides in these products and residues resulting from the processing of these minerals has the potential to complicate the management (particularly the potential for re-use) of these materials; and
- generation of radon gas through radionuclide decay of the principal NORM radionuclides creates a specific, secondary hazard to be considered in residue management.

1.1.1. Ubiquity of NORM

Although only a small number of countries use nuclear power or have industries or mining and processing operations associated with the nuclear fuel cycle, the ubiquitous occurrence of naturally occurring radionuclides in the environment means that all countries are likely to have some industries which produce NORM wastes and residues. The processing of raw materials containing these naturally occurring radionuclides can produce changes in the radionuclide concentrations in products, residues and wastes, relative to the original concentrations in the raw materials. Due to the large number of countries, sites, and materials involved, a bibliography is attached as at the end of this report, to avoid having to refer to large numbers of reports on similar work from different countries.

1.1.2. Waste or residue issues

Modern practice has tended to define a waste as a material for which no further use is foreseen. Many industries now try to re-use or re-cycle material from non-product streams as much as possible, to minimise the generation of wastes and keep operating costs as low as possible, and therefore regard these materials as residues rather than wastes.

1.1.3. Awareness issues

Until recent times, there was little awareness of NORM as a potential environmental and human health issue. The operations of many industries which produced products, wastes and residues containing NORM were not regulated or assessed for their potential radiological impact on human health and the environment. This has two major implications for the present work:

- many countries now have problems with legacy wastes, particularly from mining and mineral processing operations;

- for many legacy sites, the currently available data do not provide a good basis for modelling studies, because monitoring of such sites and their surroundings has not been required in the past; and
- misuse of some NORM wastes or legacy sites can result in unacceptable radiation exposures to members of the public (e.g., construction of housing using uranium mining or mill wastes, or siting residential buildings on NORM contaminated sites).

1.1.4. Inconsistencies in international standards

Although regulatory regimes have now been put in place in a large number of countries, the regulatory situation varies from country to country, and there are no accepted international standards for managing wastes and residues containing NORM. This lack of uniformity has implications for international trade [3], but, for the purposes of this report, it also has implications for assessing the behaviour of NORM in the environment and its potential risks. In countries where the regulatory system encourages awareness of potential issues involving NORM there is likely to be a systematic approach to monitoring and assessing the behaviour of NORM in the environment, and when and how an intervention may be required. However, where there is no regulation, the generation of wastes and residues containing NORM is unlikely to be controlled, with the result that more contaminated sites are likely to come into existence.

In 1999 the U.S. National Academy of Sciences [4] evaluated existing international guidances for NORM, their scientific bases, and resulting risk management recommendations. The resulting effort determined that nearly all guidances were based on the same epidemiological studies (for example the underground uranium miners cohort study), but the recommendations for risk management varied depending on organizational or national policy determinations on acceptability of risk. Thus, while one advisory body might find the risk of long-term mortality from exposure to a source of NORM acceptable for a member of the public at 1 in 1000 (1×10^{-3}), a regulatory body might find that risk level to be unacceptable and prefer that the risk be limited to mortality of 1 in 10,000 (1×10^{-4}). Such a situation could lead to different regulatory requirements from one nation to another for the same industry (zircon producers for example).

1.1.5. Previous work

Previously, the IAEA has run several programs which looked at the transport of radionuclides in the environment. These included the BIOMOVs (BIOSpheric Model Validation Study), BIOMOVs II ([5], [6], [7], [8], [9], [10]); VAMP (VALidation of Model Predictions) ([11], [12]); and BIOMASS (BIOSpheric Modelling and ASSessment) programs [13], [14], [15], [16], [17], [18]. These programs evaluated and used a number of models, including DOSDIM, HYDRUS and RESRAD, which are appropriate for simulating the behaviour of NORM in the environment. Although the Remediation Assessment Working Group under Theme 2 of the BIOMASS project looked at the application of models to a site contaminated with radium, the emphasis in these programs was on those radionuclides produced during the nuclear fuel cycle. Most of these radionuclides have relatively short half-lives, and are therefore not found in the natural environment. They also do not give rise to long decay chains. Therefore some of the models which have been developed for simulating the behaviour of these anthropogenic radionuclides in the environment have to undergo considerable adaptation for use in assessing the impact of NORM in the environment.

1.2. NORM industries

There are many industries and processes that produce residues containing NORM. These include:

- extraction and use of rare earth elements;
- production of niobium and ferro-niobium;
- manufacture of titanium dioxide pigments;
- the zircon and zirconia industry;
- mineral processing and metal production (refining);
- tin;
- bauxite (aluminium);
- copper;
- iron and steel;
- zinc;
- lead;
- uranium and thorium;
- vanadium;
- precious metals;
- tungsten;
- molybdenum;
- fluorspar;
- phosphate industry;
- fertiliser (product);
- phosphogypsum (by-product/residue);
- power generation (coal burning);
- oil and gas industry;
- geothermal industry;
- drinking water and wastewater treatment industry; and
- paper and pulp industry.

Detailed descriptions of many of these industries are given in [2], [19], and [20], and many of the articles listed in the bibliography. More detailed information on some of the more important NORM industries can be found in Appendix I.

Many ores which are mined and processed commercially contain naturally occurring radionuclides. In many of these ores the radionuclide concentrations are very low. In ores containing minerals such as the rare earths, the uranium or thorium concentration can be considerably elevated. One mechanism that can produce these elevated concentrations is the substitution of a uranium or thorium ion for a calcium or phosphorus ion in the mineral (lattice). In some cases elevated concentrations of radionuclides occur because of the presence of accessory minerals containing elevated concentrations of radionuclides.

The range of industries that generate NORM products and residues, the types of residues to be considered for these operations, and the typical environments in which these operations tend to occur are summarised in Table I.1 in Appendix I.

1.3. Types of assessment involving NORM wastes and residues

1.3.1. Regulatory

A growing awareness of NORM issues has led to the requirement in many regulatory jurisdictions for an environmental impact statement to be prepared as part of any application for a licence or permit to handle materials containing NORM, in particular surface or near-surface waste and/or residue disposal. Such an impact statement should be based on measurements of the characteristics of the disposal site, a sound knowledge of the materials to be handled, and a useful assessment of the impact of the operation on the surrounding environment and on the health of the workforce and members of the public who live near the site. The predictive part of this work necessitates the use of models. However, it must be noted that at the start of an operation, an environmental impact assessment is largely speculative. Once the operation starts and site-specific monitoring data are available, the original assessment can be refined and adjustments made to the operation to ensure that the impact of the operation on human health and the environment remains within acceptable limits. This means that, at the start of a NORM residue management or waste disposal project, the models required for predictive assessment are largely generic. However, as the project continues, and site-specific monitoring data become available, the models can become more site-specific in terms of the parameter values used and the environmental transfer processes simulated in the models. This should improve the predictive capability of the models with respect to that specific site and disposal operation. This iterative improvement process is particularly important for NORM because of the long half-lives of the radionuclides relative to the operational (and institutional) life-time of the management facility.

1.3.2. Operational monitoring

Modern practice in many countries requires an operator to carry out routine monitoring programs when handling, processing, or disposing of materials which may contain elevated concentrations of naturally occurring radionuclides. The data from such monitoring programs can be used to check the on-going effectiveness of waste and residue management procedures, and can also be used in computer models to assess the on-going environmental and health impacts of the operations.

1.3.2.1. On-site assessments

These assessments are primarily carried out to assess the impact of an operation on the workers at the site.

1.3.2.2. Off-site assessments

These assessments are carried out to determine the impact of an operation on the surrounding environment and on the health of members of the public.

1.3.3. Retrospective – legacy wastes and residues from past practices

In many situations, past operations involving the handling of wastes and residues containing NORM were not under regulatory control. This has resulted in the existence of so-called legacy sites which are contaminated as a result of past operations and which have not been assessed. In evaluating options for management of a legacy site, models can be used:

- as an aid in assessing the health and environmental impact of the site in its current state, and if remediation may be warranted;
- for assessing the effect of proposed remediation strategies, if the initial assessment indicates that some form of remediation is desirable; and
- for assessing the impact of mis-use of NORM residues (for example, the use of NORM residues as building materials).

However, because there was little or no attention paid to the characterisation of the sites or the design of facilities where the wastes and residues were placed, the geometry and hydrogeology of many of these sites are such that models are not easy to apply. The modern approach is to recommend that environmental impact prediction and monitoring should be a component of the design and operation of any new waste/residue management facility. This requires the use of models, and implies that waste/residue storage and disposal sites should be chosen where possible with characteristics (soil type, hydrogeology, etc.) that facilitate the use of models in assessing the health and environmental impacts of the disposed or stored material.

In adopting such an approach, it is important to have two classes of models for use in environmental and health impact assessment:

- (1) generic (or screening) models, which can be used when the available data do not allow a detailed site-specific assessment; and
- (2) site-specific models, which can be modified and refined as more data become available from monitoring programs.

Many of the models that are currently available can be used for both screening and site-specific assessment, in that they specify default values for the model parameters, and allow the user to modify the values of these parameters if site-specific data are available from monitoring programs.

1.3.4. Exposure situations/scenarios

The following section gives a brief description of some typical situations which can result in exposure to NORM:

- power station discharges of ^{210}Po and ^{210}Pb ; these isotopes are volatile at the temperatures commonly encountered in conventional power stations; therefore they can vaporise, pass up the stack and be discharged to the surrounding environment;
- storage of wastes and residues in waste stacks, waste rock piles, tailings dams, and retention ponds;
- recycling of scrap metal;
- re-use of NORM residues in building materials (fly ash, phosphogypsum); and
- re-use of NORM residues for land fill (fly ash and waste rock) and land spreading (phosphogypsum and red mud); in these situations, the future land use has to be considered when assessing the potential radiological risk associated with the re-use of the residue; typically land can be used for residential, industrial, recreational; and agricultural purposes.

Each of these situations can give rise to a range of possible exposure scenarios that have to be considered.

1.4. Current trends in NORM residue management

In recent years emphasis has been placed on development of methodologies for management of contaminated residues and sites [21]. The aim of this approach is two-fold:

- to put in place an iterative process for managing the issue, which allows for changes to be made as more information (health impact, environmental monitoring) becomes available; and
- to build confidence among all stakeholders, by ensuring that the process is clearly understood by all stakeholders, and that all stakeholders are involved in decision making.

1.5. Objectives

The stated objectives of the NORM Working Group were “modelling of naturally occurring radioactive material (NORM) releases and of the remediation benefits for sites contaminated by extractive industries (U/Th mining and milling, oil and gas industry, phosphate industry, etc)”.

With these objectives in mind, the working group identified four major groups of stakeholders that have a strong interest in problems involving NORM. Each group of stakeholders has expected outcomes from a study of this type. These are summarised in Table 1.2.

Table 1.2. Stakeholders and expected outcomes for NORM modelling.

Stakeholders	Expected Outcomes
Industry	A list of models that can be used for assessment of the impact of manufacturing or disposing of materials containing NORM that result from the operations of the particular industry, together with an evaluation of the suitability and reliability of the models. Environmental impact assessment. Occupational health and safety. Data sets that can be used to check and/or verify an available model, together with an evaluation of the reliability of the data and the uncertainties in the data.
Public	Proof of safety Environmental impact assessment. Trust in the procedures (models, data acquisition, assessment procedures, regulatory decisions)
Governments/ Regulators	Proof of compliance with acceptable levels of risk, e.g. remediation targets. Environmental impact assessment. Occupational health and safety. Trust in the procedures
Modellers Scientists	A clear statement of the problem(s) Validated and appropriate data sets for model development, testing and verification

The overall objectives of the working group could be met by meeting the aims summarised below:

- to present a brief review of the currently available information on NORM modelling;
- to summarise the similarities and differences between NORM and anthropogenic radionuclides in the environment;
- to determine what models are already available;

- to develop guidance on whether models should be
 - industry specific;
 - micro-scale or macro-scale;
- to develop guidance on remediation issues.

Additional aims of the present work are to deliver the expected outcomes, as far as is possible; or develop procedures that will assist in meeting these outcomes.

1.6. Scope

The IAEA Safety Glossary [22] defines NORM as “*Radioactive material containing no significant amounts of radionuclides other than naturally occurring radionuclides*”.

The glossary also notes that:

- The exact definition of ‘significant amounts’ would be a regulatory decision;
- Material in which the activity concentrations of the naturally occurring radionuclides have been changed by a process is included in NORM [22].

The theme of this report is the modelling of naturally occurring radioactive material (NORM) releases, and the remediation of sites contaminated by NORM as a result of mineral extraction and processing (uranium and thorium mining and processing, the oil and gas industry, the phosphate industry, etc.).

The major processes that can lead to detrimental impacts on the environment and on human health are:

- Discharge of material into the atmosphere;
- Dispersion of material in the atmosphere;
- Deposition of material on the ground surface;
- Resuspension of deposited material;
- Burial of material in the ground;
- Transport by surface water;
- Transport by groundwater;
- Radionuclide decay (generation of radon and its progeny); and
- Uptake into the food chain and drinking water.

There are two major detrimental effects that contaminants can have on the environment. The first of these is direct effects on biota (flora and fauna) from exposure to radiation from radionuclides in the environment. The second is land degradation, which can result in loss of habitat for flora and fauna and/or the loss of agricultural land.

The basic questions concerning the scope of this work can be summarised as:

- Which pathways are important for transfer of NORM, both in release to the environment and transfer through the environment?
- Which transfer processes are important?
- How should local/site-specific factors/issues be addressed?

Situations involving NORM which should be considered in the context of the EMRAS program include:

- management of wet and dry tailings;
- shallow ground burial of wastes;
- volatilisation of polonium and lead isotopes in smelters and coal-fired power stations, and discharge of these isotopes to the atmosphere from plant chimney stacks;
- management of waste rock piles;
- management of retention ponds;
- management of scales and sludges;
- management of other NORM residues and legacy wastes;
- recycling/re-use of NORM residues in building materials;
- use of NORM residues in landfill and products.

1.7. Structure of this report

The general principles of modelling as applied to NORM are presented in Chapter 2. Chapter 3 discusses the different types of exposure scenarios that are appropriate in a discussion of NORM, particularly legacy sites which exist as a result of past operations. This section also introduces three hypothetical scenarios for testing models, and four real scenarios. Chapter 4 discusses the testing and further development of the hypothetical scenarios, and Chapter 5 discusses the testing of the real scenarios.

A discussion of the results of the development and testing the models, hypothetical scenarios and real scenarios is presented in Chapter 6.

Chapter 7 presents recommendations for further work.

Appendix I presents a discussion of many of the industries considered in this work, with particular attention given to situations where naturally occurring radionuclides can become concentrated in product, residue and waste streams during mineral extraction and processing.

Appendix II to Appendix VIII provide the detailed description(s) of the topics discussed in Chapter 2 to Chapter 5. The detailed specifications of the hypothetical scenarios are given in Appendix III, and the results of the testing of these scenarios are given in Appendices IV, V and VI. The detailed specifications of the hypothetical scenarios are given in Appendix VII and the results of the model testing work for these scenarios are presented in Appendix VIII.

A description of work done by the U.S. Environmental Protection Agency to develop methods for evaluating generic radiation risks for situations involving NORM is presented in Appendix IX.

A comprehensive bibliography is given at the end of this report.

CHAPTER 2. MODELLING

To perform an assessment of the impact of NORM in the environment, it is evident from the previous discussion that:

- (1) Models are a potentially useful part of the assessment process.
- (2) To provide more realistic predictions, it is important that models be used in conjunction with field measurements to the greatest extent possible.
- (3) Models can be used where there are gaps in the available data and where little or no data are available (e.g. for screening purposes or for predicting possible outcomes of a proposed action).
- (4) The limitations and appropriateness of the models and supporting data should be clearly understood by the user and clearly explained to the stakeholders.

The environment is very complex and the processes that move radionuclides through the environment are also complex. The natural variation in data and the associated collection processes may lead to additional uncertainty in the model results.

The complexity of the overall problem is such that to construct a useful model a number of assumptions and approximations have to be built into the model. Each of these assumptions and approximations has the potential to limit the range of application of the model and increase the uncertainty in the model predictions. Methods have been developed to deal with and explain these uncertainties. For the purposes of the present report only deterministic calculations have been examined.

2.1. Overview of current status of international experience

The purpose of this section is to describe some of the models currently available for NORM assessments, their strengths and weaknesses, and how they can be used. These models should be able to predict the effects of exposure to NORM in the environment, and assess any resulting environmental impact.

Historically most models of radionuclide transport in the environment have concentrated on nuclear power plant impacts, i.e. fission products (with short decay chains). Other models have been developed to examine the consequences of direct exposure (external and internal) to radionuclides, both natural and man-made, present in the environment either intentionally or accidentally. NORM includes a number of radionuclides that initiate very long decay chains. The nuclides in these decay chains have a very wide range of physical and chemical properties.

2.2. Models and Their Uses

A number of models were reviewed during the BIOMOVs, BIOMOVs II, VAMP and BIOMASS projects. However, most of these models were not considered suitable for the current project, because they only simulate the behaviour of single, specific radionuclides, and do not have the databases that would facilitate their use for simulating the behaviour of NORM in the environment. Models that could be used for NORM assessment fall into three categories:

- (1) screening models;
- (2) compliance models; and
- (3) detailed impact assessment models.

2.2.1. Screening models

These models are usually relatively simple, and are designed for preliminary screening, to see if the scenario being modelled warrants further investigation, to establish spatial boundaries of land areas requiring further field investigation and sampling, or to estimate exposures where the data available are incomplete and more complex models cannot be applied. Details of specific screening models are given in Appendix II.

2.2.2. Compliance models

These models are designed to test for compliance with regulatory requirements, and are usually simplified, to estimate upper limits to radionuclide concentrations and doses. Details of specific compliance models are given in Appendix II.

2.2.3. Detailed impact assessment models

These models are designed for detailed environmental impact assessment. Details of specific models are given in Appendix II.

2.3. Models used in this work

The models that were used in the work described in this report are listed in Table 2.1. A more detailed description of these models is given in section 2.4.

Table 2.1. A list of the hypothetical scenarios, the models that were applied to each scenario, and users.

Scenario	Models	Users
Point source	COMPLY [23]	J. Horyna, R. O'Brien
	CAP-88 [24], [25]	J. Horyna
	PC-CREAM [26]	P. McDonald, R. O'Brien, V. Amado
	CROM [27]	D. Perez Sanchez
Area source	DOSDIM + HYDRUS	T. Zeevaert, G. Olyslaegers
	RESRAD (onsite) [28], [29]	J. Horyna, R. O'Brien
	RESRAD-OFFSITE [30], [31]	C. Yu, P. McDonald, R. O'Brien, V. Amado, J. Horyna
	PRESTO v4.2	J. Horyna
Area source + river	RESRAD-OFFSITE	C. Yu, P. McDonald, R. O'Brien

2.4. Model Descriptions

The models that were used in this work are described in Appendix II. This Appendix also lists other models that were noted as potentially useful but not actually tested by project participants.

2.5. Model Documentation

To be useful to a wide range of users, and to comply with legal and regulatory requirements, modelling packages should be readily available to potential users and well documented. This documentation should include descriptions of the following:

- the purpose of the package;

- a clear statement of the conceptual model framework used as a basis for the software - what kind of situations the model was designed to solve;
- the mathematical procedures used to solve the equations used in the model(s) contained in the package;
- the verification and validation procedures used to test the model(s);
- the input parameters used in the model(s);
- the validation procedures used to test the values assigned to the different parameters in the model(s);
- the assumptions used to set up the model(s);
- the limitations of the model(s); and
- the availability of the package.

The project participants noted that many models are not readily available and many of those that are available are not well documented.

2.6. Use of Models to Develop Screening Dose and Risk Lookup Tables and Graphs

During the course of this investigation, an innovative methodology was presented on the use of both screening and environmental impact assessment model calculations to determine potential dose and risk from exposure to specific types of NORM residues. Using separate models, and assuming certain constant environmental conditions, types of NORM residue, and exposure scenarios, the radionuclide concentration and time of exposure were varied for performing multiple calculations.

Tables and graphs of the results were developed which could be used for fast screening evaluation of potential radiation dose and risk based upon annual time of exposure and concentration of NORM radionuclides at the waste site. Such lookup tools could be utilized in commonly encountered NORM exposure situations for screening the potential hazard of a site before taking next steps, including further site investigations and detailed modelling. The methodology and results for generic long term exposures to uranium mine wastes in recreational, and building material scenarios are provided in Appendix IX.

CHAPTER 3. SCENARIOS

3.1. Overview and rationale

It is already apparent that there are a very large number of possible situations involving NORM that may require the use of models for assessment purposes. These include sites with widely differing characteristics, a wide range of processes, and a wide range of materials. A preliminary literature search showed that many of the available data sets are not readily suitable for comparison with the predicted outcomes of computer models. Therefore it was decided to begin by developing a set of basic hypothetical scenarios which would approximate a wide range of real situations and which could be used to test and compare predictions from different models. Simultaneously, a more comprehensive search was undertaken for real scenarios that would meet the requirements of the study.

3.2. Legacy sites

The existence of a large number of historical sites contaminated with NORM has already been noted. These sites exist because of past operations which were largely carried out without regulatory control, and now pose a problem for governments for a number of reasons, including location, the possible need for remedial action, and difficulties in assessing the possible health and environmental impact of such sites.

3.2.1. *Contaminated urban areas*

Many historically contaminated sites, particularly those associated with product manufacture, are in urban areas. These sites were often originally developed in urban areas because of easy access to transport facilities, etc. In some cases the sites were originally in rural areas, but urban development has subsequently encroached on or enveloped the sites. Models are very useful tools for assessing the potential radiological impact of such sites.

3.2.2. *Remediation actions*

As awareness of the existence of historically contaminated sites has increased, the need for assessment of the radiological impact of such sites has also increased. Such assessments typically require measurements of radon exhalation rate, radionuclide concentrations in air, soil, surface water, ground water and locally grown foodstuffs, together with the modelling tools to assess the impact of the sites on the surrounding population and environment. If the assessment indicates that the impact is unacceptable, some form of remediation is required. This remediation may range from leaving the contaminated material where it is, burying it beneath clean soil, or removing it to another site for disposal. For completeness the effectiveness of the remediation action must be checked; this can be done by making post-remediation measurements and modelling assessments.

3.2.3. *Difficulties with remediation of legacy sites*

There are some awkward problems associated with assessment and remediation of historically contaminated sites:

- many of these sites are not easily amenable to modelling;
- in the past, many waste sites were frequently chosen with ease and economy of waste disposal, rather than safety requirements and minimal environmental impact, as priorities. Changing land use, particularly residential encroachment on or over such sites

complicates the potential problems. This means that remediation of such sites can be costly. The costs result from the efforts required to assess the impact of the sites on the surrounding environments, taking appropriate actions, and adverse publicity for the relevant industry.

In some cases it is not possible to determine who is legally responsible for any assessment and remedial work that is required. In these cases it is common practice for government agencies to bear the costs of any work that is required. In these instances, the use of compliance models becomes important in demonstrating potential radiation risks, and extent of necessary cleanups.

3.3. Hypothetical scenarios

Three basic scenarios which cover many practical situations are discussed in the following sections. These scenarios are based on a point source, an area source, and an area source close to a river.

3.3.1. *Point source*

This type of scenario is usually associated with chimney stack discharges from power stations, processing plants, factories, etc. The principal mechanism by which material is dispersed into the environment following discharge from a chimney stack is atmospheric dispersion. However, once any contaminants settle on the ground surface, other mechanisms such as surface water transport, migration of radionuclides in soil, groundwater transport, resuspension and uptake into the food chain become important. The hypothetical point source scenario is presented in Appendix III.2.

3.3.2. *Area source*

This type of scenario is usually associated with waste rock heaps, ore storage heaps, tailings heaps, and product storage heaps. Contaminants can be suspended into the atmosphere and dispersed, or dispersed by surface water and groundwater. Clearly the resuspension pathway can be neglected if the wastes or residues are buried. However in many legacy situations the material of interest has not been buried or the action of wind and surface water has eroded away some or all of the covering material. The hypothetical area source scenario is presented in Appendix III.3.

3.3.3. *Area source plus river*

In many historical situations mineral processing operations were often carried out near rivers. This was for easy access by water transport and/or because a convenient source of process water was needed. Rivers were also used in some cases as convenient drainage outlets for disposing of waste materials. Modern processing plants are built near rivers for similar reasons. Although disposal of waste by discharge into rivers is now strictly controlled in many countries, there are enough (historical) disposal sites near rivers to make this scenario important. The hypothetical area source plus river scenario is presented in Appendix III.4.

3.4. Real Scenarios

3.4.1. *Lignite power plant (LPP II) scenario*

In Greece, about 70% of the installed capacity of electrical energy is produced from two main lignite power plants (LPPI: 3020 MW and LPPII : plant A 550 MW and plant B 300 MW). A detailed description of this scenario is given in Appendix VII.1.

3.4.2. *Former gas mantle production plant (Camden) scenario*

Contamination resulting from the operations of a thorium processing facility and two former gas mantle manufacturing facilities in Camden, New Jersey, has been assessed [32], [33] Some remediation has been carried out.

This is a good, well-documented example of a legacy site in an urban area. The reports cited here provide considerable detail of the distribution and level of contamination, and the remedial work that has been carried out. Rather than attempt to reproduce the data here, the interested modeller is referred to the reports. The distribution of contamination is highly inhomogeneous, and modellers in the United States used both screening and compliance models to evaluate site radiation doses and risks. However, groundwater infiltration was generally not found to have affected the site, or resulted in migration of radionuclides.

3.4.3. *Phosphogypsum disposal site (PGDS1)*

This site consists of several contiguous phosphogypsum stacks positioned between a lake and the sea. The groundwater and surface water flows are predominantly in the direction of the lake. The details are given in Appendix VII.2.

3.4.4. *Phosphogypsum disposal site (PGDS2)*

This site consists of one large phosphogypsum stack approximately 1-2 km from the sea. The groundwater flow is towards the sea. The site has undergone some remediation work. A retaining wall surrounds the stack to restrict the flow of leachate. There is a series of monitoring points around the stack. There is also a series of wells on the downstream side of the stack. Leachate extracted from these wells is pumped back to the top of the stack. The details are given in Appendix VII.3.

With the available information the characteristics of the site can be summarised as follows:

- (1) phosphorite consumption: $350-400 \cdot 10^3 \text{ t a}^{-1}$;
- (2) type of process: mainly Prayon – wet process;
- (3) production of phosphoric acid: $60 - 100 \cdot 10^3 \text{ t a}^{-1}$;
- (4) production of slurry: $300 \cdot 10^3 \text{ t a}^{-1}$;
- (5) the concentration of phosphogypsum in the slurry was 10 – 20 %;
- (6) for at least two decades phosphogypsum was discharged directly into the sea, at some 100 m off the coast;
- (7) since the late 1970's phosphogypsum residues were collected in the landfill through pipes with water circulating in a closed circuit;
- (8) until 2,000 there was no regulatory requirements applicable to this site from a radiological point of view;
- (9) some components of the installation were decommissioned before 2,000; some other components were recycled or reused.

The site is within the premises of a refinery and related industrial area. The installations included in the remediation plan are:

- (1) one plant for phosphoric acid production, to be decommissioned;
- (2) three phosphorites stores, to be demolished;
- (3) four phosphoric acid tanks, to be decommissioned;
- (4) two pipes to transport slurry from the production plant to the phosphogypsum landfill and water from the landfill to the plant;
- (5) one phosphogypsum landfill, located a few kilometres from the plant and a few hundred metres off the seacoast.

Between 1967 and 1981, phosphogypsum residues were directly discharged into the sea; between 1981 and 1992, residues were cumulated in the landfill (see Figure VII.10). This landfill, composed of 4 basins (one is empty), is about 55 ha wide; the mean height of phosphogypsum residues is 14.5 m. In 2002 an external wall, made with bentonite cement, 60 cm thick, 3,550 m long, at a distance of about 5 m from the heap of residues was constructed; this wall penetrates 3 m into the slab of underground clay. A drainage trench between the wall and the heap was constructed, with a series of wells to collect rainfall percolate. In addition, an experimental station for chemical treatment of percolate was installed, in order to separate the dry component - to be deposited in the landfill - from purified water. The whole trench was lined with waterproof materials.

Future plans for the site include decommissioning of the phosphoric acid plant. This could be a useful modelling exercise for future studies. The landfill will be covered with a double plastic liner, which will in turn be covered by 2 metres of clean soil.

Measurements of uranium concentrations downstream of the wall indicate that the ratio $^{234}\text{U}:$ ^{238}U may be starting to increase. If this trend continues, it will indicate that the retaining wall is functioning as required.

CHAPTER 4. TESTING OF HYPOTHETICAL SCENARIOS

4.1. Point source

The models used for testing this scenario included CAP-88, COMPLY and PC-CREAM. A description of these models is given in Appendix II. CAP-88 and COMPLY are screening/compliance models, which make conservative assumptions and require simple input data. Two modellers used PC-CREAM; this is a much more complex model designed to carry out detailed assessments, and requires much more input data, particularly with respect to the food chain pathways.

4.1.1. COMPLY/CAP-88

Two modellers tested this scenario using COMPLY/CAP-88. Both modellers obtained the same results.

The wind rose data specified in the scenario description had to be modified for use in CAP88. No changes to the radionuclide database were required, as ^{210}Po and ^{210}Pb were already included in the CAP88 database.

The COMPLY software is available for downloading on the Internet at the website: <http://www.epa.gov/rpdweb00/assessment/comply.html#download> This package is a computerised screening tool for evaluating radiation exposure from atmospheric releases of radionuclides. It was developed originally for demonstrating compliance with some U.S. EPA and U.S. Nuclear Regulatory Commission regulations. However, although the U.S. EPA does make it available on the Internet, the agency no longer provides support for it; the model code CAP-88 is now the only software supported by the U.S. for these purposes.

4.1.2. PC-CREAM

Two modellers used PC-CREAM to test this scenario. Both modellers obtained the same results, and reported the same difficulties in using the package:

- The wind rose data specified in the scenario description was not appropriate for PC-CREAM, and had to be converted to the PC-CREAM format to be able to perform the model runs;
- The radionuclides in the PC-CREAM database did not include ^{210}Po and ^{210}Pb .

The required radionuclides were added to the PC-CREAM database. The process for doing this is not well documented.

4.1.3. Comparison of results

Results from the COMPLY/CAP-88 and PC-CREAM testing are given in Appendix IV. The doses calculated by COMPLY were higher than those calculated by PC-CREAM. This is consistent with the different nature of the two models; COMPLY/CAP-88 is designed to check compliance with regulatory requirements and is deliberately conservative, whereas PC-CREAM is a very detailed impact assessment model. In view of this, the higher doses predicted by COMPLY/CAP-88 are acceptable.

The fact that different modellers obtained the same results using COMPLY/CAP-88 is not surprising as this is a relatively simple model. The agreement between the results obtained by

different modellers using PC-CREAM is more interesting, as this is a much more complex package, and there are many places where different input data or different exposure pathways could be selected by the user. The agreement in the results suggests that the overall structure of the program is sound, and the choices required of the user are clear. However, it must also be noted that this scenario is relatively simple, with well-defined source-receptor geometry.

4.2. Area source

The models used for testing this scenario were DOSDIM (+ HYDRUS), RESRAD (onsite, version 6.2), and RESRAD-OFFSITE. These are all complex models, although RESRAD (onsite) is considerably simpler than the other two models. All three models have extensive databases and allow many of the default parameter values to be changed.

4.2.1. DOSDIM + HYDRUS

One modeller carried out the first set of calculations, and these were subsequently checked and revised by a second modeller. Several points were made:

- For the waste, the K_d value for the unsaturated soil (80 % sand and 20% clay) was used. Using the K_d value for clay in the waste (as proposed in the scenario) gave no leaching out of the waste.
- The specified hydraulic conductivity of 10 m a^{-1} was considered unrealistic for the current scenario. Therefore the HYDRUS standard value of 230 m a^{-1} (0.63 m d^{-1}) for 80 % sand and 20% clay (taken from the HYDRUS Rosetta database) was used in the calculations.
- Soil-plant uptake factors were not specified in the original scenario description. Therefore assumptions had to be made, in order to calculate doses resulting from ingestion of contaminated food.

4.2.2. RESRAD (Version 6.2)

Two modellers used RESRAD (Version 6.2) to look at the area source scenario. This package was not designed for offsite calculations, but was used to approximate offsite calculations as follows.

The model was run for the case of a waste pile as specified in the scenario description, plus a waste pile that extends under field # 2 and has waste with the same characteristics (depth, radionuclide concentration, K_d values, etc.) as those given in the scenario description, with a house situated as shown in Figure 9 (step 1).

The model was then run for the case of a waste pile under field #2 only, with the waste having the characteristics specified in the scenario description (step 2).

The results from step 2 were then subtracted from the results of step 1, to give the doses due to the waste pile as specified in the scenario description.

The results from these calculations are not presented, as they are similar to those presented in the following section on the use of RESRAD-OFFSITE.

4.2.3. RESRAD-OFFSITE

Four modellers tested the area source scenario using RESRAD-OFFSITE. This package allows the layout of the site being studied to be set up and modified by the user. The main points that arose from this work can be summarised as follows:

- the package is extremely flexible, and gives default values for many input parameters, but also allows the user to specify values for a large number of input parameters;
- the values of the input parameters can be easily modified;
- the physical layout of the site (house positions, location of waste, location of fields, use of fields, position of any surface water bodies, direction of groundwater flow, etc.) can be specified and easily modified by the user;
- it is extremely important to ensure that all modellers use the same values for the input parameters.

When early results were compared, it was found that different users had specified different values for some input parameters and different uses for the fields allowed in the site specification. When these differences were resolved and agreed values were used, the different modellers obtained the same results.

Some of the results of this work are presented in Appndix V.2.

4.2.4. Comparison of results from different models

The general agreement between the DOSDIM and RESRAD results was good, considering the differences between the models. However, whereas DOSDIM + HYDRUS predicted that there would be no leaching of radionuclides from the waste if the waste was assumed to be clay, RESRAD did predict slow leaching.

The HYDRUS standard value of 230 m a^{-1} (0.63 m d^{-1}) for the hydraulic conductivity of a mixture of 80 % sand and 20% clay (taken from the HYDRUS Rosetta database) was used in the HYDRUS calculations, whereas RESRAD used the values specified in the scenario.

Soil-plant uptake factors were not specified in the original scenario description. Therefore assumptions had to be made for both models, in order to calculate doses resulting from ingestion of contaminated food. The scenario specifications were subsequently revised to include the soil-plant uptake factors.

This scenario is much more complex than the point source scenario, in terms of specification and choice of input data. The importance of the leaching process and the ground water pathways when dealing with surface and near-surface disposal of waste means that there are many choices to be made by the user when setting up these packages to model this scenario. This was noted by the DOSDIM user, who pointed out several important omissions in the original scenario specifications, and by the RESRAD users, who had difficulty agreeing on the land use specifications for the calculations. The resolution of these difficulties led to two important conclusions:

- (1) it is not always possible to specify the scenario without going through an iterative process of testing and modification;
- (2) good communication between modellers is essential, to ensure that all modellers use the same site specifications and the same values for environmental parameters.

CHAPTER 5. TESTING OF REAL SCENARIOS

5.1. Lignite power plant (LPP II) Scenario

5.1.1. *PC-CREAM calculations*

This scenario was tested by one modeller, and checked by a second modeller, using PC-CREAM. Details of the data used in the calculations are presented in Appendix VIII.1, together with the model results. Some of the real data were presented in a format that could not be used directly in PC-CREAM, and default values were used in the calculations. The agreement between measured and calculated radionuclide concentrations was surprisingly good. However, it should be noted that the model predictions are based on the data given in Appendix VIII.1, and it was assumed that the discharge rate was constant over the 50-year period for which doses were estimated; it is known that annual discharge rates are variable.

5.1.2. *COMPLY calculations*

One modeler used the COMPLY code to test the scenario.

5.1.3. *CROM calculations*

One modeller used CROM to test this scenario.

5.1.4. *Comparison of results*

The doses estimated using PC-CREAM and COMPLY were similar in magnitude, which is encouraging, because of the uncertainties in the source terms and the differences between the models.

The predicted ground surface concentrations from CROM are higher than the measured values, but of approximately the same order of magnitude.

The model calculations could be improved if:

- more detailed wind rose data were available;
- appropriate (local) values for the wet and dry deposition coefficients were available;
- a better estimate of the conversion factor from power output to radionuclide discharge rate was available.

5.2. Former gas mantle production plant (Camden) scenario

This scenario has not been tested by the working group.

5.3. Phosphogypsum stack – PGDS1

This scenario has not been tested in great detail, but some preliminary testing has been carried out. This scenario has features that may require special attention by modelers, in that the phosphogypsum has been deposited into a lake.

5.4. Phosphogypsum stack – PGDS2

This scenario has also not been tested in detail, as the data were made available late in the program. However, some preliminary testing has been carried out. This scenario has two unusual features that may complicate the modeling work. These are the presence of the retaining wall, and the pumping back of leachate extracted from the sump wells to the top of the stack.

CHAPTER 6. DISCUSSION

A range of models and scenarios has been discussed in this report. The models range from simple screening models to complex environmental transport models, and include models designed specifically for demonstration of compliance with regulatory requirements.

The results of the work carried out can be summarized briefly as follows. Comparing results of a simple screening model with those of a complex transport model (the hypothetical point source scenario) showed that the radionuclide concentrations predicted by the simple model were higher (more conservative) than those predicted by the complex model. This is as expected as the simple models are designed to be conservative.

Comparison of the predictions from two complex models for the area source scenario showed that:

- it is important that all modellers use the same site specifications and the same values for environmental parameters;
- it is also important to specify values for the environmental parameters that are consistent with the results of observations in real environmental scenarios;
- the results from the two models were generally similar; and
- different modellers using the same model obtained the same results once the input data had been agreed.

In this report, the emphasis has been on deterministic calculations. Probabilistic calculations and uncertainty estimation have not been considered.

Some of the models considered in this work give the user little flexibility in terms of input data. This is particularly so for the screening and compliance models. The more complex models give the user much more access to the environmental parameter values and allow many of these values to be changed. However, in one case, the required radionuclides were not included in the model database, and considerable effort was required to add these nuclides to the database.

Important issues when using models are the capabilities of the model(s) being used, and the capabilities of the modeller(s). In general simple models require little training in their use, and little input data. However, these models have limited application (screening) and do not always give useful information. When carrying out detailed assessments, complex models are usually required. Considerable training and experience is needed to understand the requirements (in terms of input), use and limitations of these models, and to interpret the model predictions.

Models are often used to demonstrate compliance with regulatory requirements and as part of assessment and development methodologies designed to build and maintain confidence among project stakeholders (operators, workers and public). These models and appropriate documentation should be readily available to potential users. In many cases, the legal implications of an environmental assessment can be considerable. Therefore it is important that the available documentation should provide detailed descriptions of:

- development of the model;
- validation of the model;

- verification of the model; and
- validation of input parameter values.

The RESRAD programs appear to meet most of these requirements. DOSDIM and HYDRUS have been used on several occasions, but it is not clear that the detailed documentation described above is readily available to a wide range of potential users.

The methodologies used in PC-CREAM are described in detail [26], but as noted in this report, the databases in PC-CREAM do not include all the naturally occurring radionuclides, and these have to be added by the user.

There is a marked lack of models capable of handling area source situations where the geometry of the waste is complex (for example, varying waste thickness, or multiple waste stacks). Many legacy sites have these characteristics. This may not be important in most cases, because measurement involves averaging in both time and space, and inevitably tends to smooth out small-scale variations. Nevertheless, further work is needed on situations of this type, to determine whether the available models are suitable for assessing the impact of such sites.

CHAPTER 7. RECOMMENDATIONS

The work carried out during this program has resulted in the identification of several important issues that require consideration in the selection and utilization of computer models for NORM risk assessment. These issues discussed below cover suitability, selection, use and misuse of available models, as well as training and guidance for modelers, and acquisition of data for model inputs. In addition, a series of recommendations are made for future work, with particular emphasis on integration with other programs and needs.

7.1. Suitability of models

Considerable thought needs to be given to determining the suitability of models for particular applications/scenarios. This is partly due to the complexity of the environment, but also the difficulty of developing and testing detailed models. It is extremely important to understand the purpose for which a particular model was designed and to understand which model(s) don't work in particular cases.

7.2. Pitfalls in using models

There are many potential issues involved in developing, testing and using models. These include assumptions, misuse of models, training, development of data sets for model validation, ease of use, and understanding how and when models should be used.

7.2.1. *Conceptual model assumptions*

Many assumptions are made when developing mathematical models of environmental processes. These assumptions generally fall into three categories:

- (1) assumptions as to which processes to include in the model;
- (2) assumptions as to the level of detail of the processes that are included in the model;
- (3) assumptions that are included to simplify the mathematics involved in the development of the model.

In many cases model developers do not explicitly list all the assumptions in the model documentation. This can easily lead to models being misused, or their predictions being incorrectly interpreted.

7.2.2. *Misuse of models*

There are a number of screening models available. Since these models are often relatively easy to use, it is tempting to use screening models in applications where they are not appropriate. This can lead to situations where management decisions are made on the basis of model predictions that are not applicable to the particular situation. This tendency is exacerbated by the fact that there are very few models readily available for carrying out detailed health and environmental impact prediction and assessment.

It must also be noted that complex, detailed models are sometimes used in situations where a simple model would be more appropriate. In some cases, software developed for a particular (or group of) scenario(s) can be misused by a modeller who does not understand the underlying conceptual model, resulting in incorrect or inappropriate results.

7.2.3. Training

Modellers need to be well-trained in the use and application of the available models, and particularly in the interpretation of the results produced by the models. Many models calculate the values of environmental parameters at a point in space and time, whereas most measurements involve averaging in both space and time. This can lead to misinterpretation of model predictions. This problem can be mitigated by close cooperation between field measurement staff and modelling staff, so that each is aware of the other's difficulties and requirements.

7.2.4. Ease of use

Environmental models can be very complex, and therefore difficult to use. Ease of use can be greatly enhanced by the provision of good documentation and help screens, databases containing default values of environmental parameters, and facilities for plotting the results of calculations. It is also extremely important to provide the model user with simple procedures for changing these default values and for adding extra data to existing databases.

7.2.5. Data sets for model testing

There is an obvious need for well-documented, readily available data sets for NORM sites (both legacy sites and current operations), to facilitate assessment and model testing and to provide parameter values for the models. The choice of parameter values also needs to be well documented, as there may be a regulatory requirement to use a particular model to verify compliance with license requirements, or to use specified values for environmental parameters when carrying out assessments.

7.2.6. Guidance on use of models

Guidance needs to be developed on how and when to use models in specific situations, and which type of model is best suited to particular problems or groups of problems. Models can be used for many different purposes, including:

- as planning tools in order to suggest new measures or improvement of existing measures;
- to aid in the process of assuring compliance with regulatory requirements and public expectations;
- as screening tools;
- for safety assessment;
- for environmental impact assessment;
- for assessing occupational, public and environmental safety;
- for assessing options for remediation of legacy sites;
- as an aid to planning new operations.

7.3. The overall assessment process

Modelling should be treated as part of an iterative assessment process, which can involve planning, development, monitoring, and modification of procedures. This process should evolve as more information becomes available and as operational experience leads to an increase in understanding of the situation.

7.3.1. Importance of communication

In this type of approach to assessment, communication between all stakeholders is important. The overall objective and progress of any process/operation has to be clearly communicated to all stakeholders. Flexibility is also critically important, because procedures have to be modified as knowledge of the process increases.

There are many issues to be considered, including regulatory, legal, environmental, and economic issues, and public concerns.

Specialized models may need to be developed for specific situations such as modelling of groundwater flow and for specific industries such as the phosphate industry and the uranium mining industry. Good communication is essential for this process, so that all stakeholders understand and trust the process.

It is important to place strong emphasis on good communication between all stakeholders involved in a particular evaluation, and also on good communication and cooperation between the different groups of scientists (in particular field measurement experts and modelling experts) to ensure that the requirements of the different groups are clearly understood by everyone involved in the project.

7.4. Follow-up of this work

There are several important issues that have arisen from the work described in this report. These include:

- continuation of the work on development and application of models for use in NORM problems – these problems can include site-specific problems, process-specific problems and problems associated with planning future actions, such as the development of a new mine or processing plant, remediation of existing (legacy) contaminated sites and buildings, commissioning of new plant, decommissioning of existing plant, use of residues, and other situations where models can be useful;
- continuation of the work on development of real scenarios for model testing and validation;
- acquisition of more validated data sets from real sites, for model testing;
- testing of new models;
- development of the capability to carry out probabilistic calculations;
- development of rigorous methods of estimating uncertainties in model predictions and estimates;
- guidance for modellers on use and selection of models for certain purposes, illustrated with case studies;
- guidance for modellers on use and selection of data for model inputs;
- dissemination of results in scientific and technical publications, and to stakeholders; and
- integration of model output with other Agency safety assessment tools.

APPENDIX I. DESCRIPTION OF NORM INDUSTRIES

Products, wastes and residues contain radionuclides which occur in the natural environment are collectively known as NORM. The radionuclides include the members of the primordial decay chains resulting from the decay of ^{238}U , ^{235}U and ^{232}Th , and single extremely long-lived (primordial) radionuclides such as ^{40}K , ^{117}In , and ^{87}Rb . In the case of the primordial decay chains, the first member of each chain has an extremely long half-life (10^8 years or longer). The NORM industries considered here are those which extract and/or process natural materials, and which modify the activity concentration of naturally occurring radionuclides in the raw materials. These modifications may warrant the radiological assessment of such actions.

There is obviously a wide range of industries that generate NORM products and residues. The types of residues to be considered for these industrial operations are summarised in Table I.1. This table also shows the type of environment in which these operations tend to occur.

Table I.1. A list of the major industrial processes which generate NORM residues, their occurrence, and the types of products, wastes and residues generated.

Industry	Environment	Products	Form of Wastes or Residues	NORM wastes or residues
Mining and milling	Everywhere	Mineral	Liquids and solids	Tailings, process water, scales, evaporites
Mineral processing	Everywhere	Metal	Scales, sludges, volatiles	slags, tailings
Phosphate industry	Everywhere	Fertiliser, phosphoric acid	Liquids and solids	Phosphogypsum, scales
Power generation (fossil fuels)	Everywhere	Electricity	Solids and gases	Ash, mine water
Oil and gas production	Marine and on-shore	Oil, gas	Liquids and solids	Scales, sludges, process water
Water treatment	Everywhere	Potable water	Liquids and solids	Sludges, bio-solids, scales, contaminated filters and residuals

A more detailed discussion of these industries is given in the following sections.

I.1. Extraction and processing of mineral sands

I.1.1. Niobium and ferro-niobium production

Niobium is found together with other elements in ores such as tantalite $\text{Ta}_2\text{P}_6(\text{Fe},\text{Mn})$, columbite $\text{Nb}_2\text{P}_6\text{Fe}$, fergusonite $(\text{Nb},\text{Ta})\text{O}_4(\text{Y},\text{Er},\text{Ce})$, samarskite, pyrochlore $(\text{Na},\text{Ca},\text{Ce})_2\text{Nb}_2\text{O}_6\text{F}$, koppite and loparite. The ore is processed by melting with sodium or potassium hydroxide, dissolving in hydrochloric acid, and processing with chlorine at 750-800°C. The resulting powder is then further purified by a number of methods. Ferro-niobium may also be produced using a process involving a high temperature exothermic reaction between pyrochlore and aluminum powder.

Pyrochlore usually has a high activity concentration of both ^{238}U and ^{232}Th decay series radionuclides. Reported activity concentrations range from 7 to 80 kBq kg^{-1} of ^{232}Th and 6 to 10 kBq kg^{-1} of ^{238}U .

1.1.2. Manufacture of rare earths

The most important sources of rare earth elements are monazite (Ce, La, Nd, Th) PO₄ and bastnaesite (Ce, La,...)(CO₃)F. The monazite ore concentrate is obtained from suitable sands by a gravimetric and electromagnetic sorting. Strong acids or alkaline solutions are then used on the concentrate and lanthanides are precipitated. The bastnaesite ore concentrate is obtained by a wet process in which it is successively washed and separated in water. This concentrate is washed with hydrochloric acid and calcined in order to produce a crude oxide containing 90% of lanthanide oxides.

Monazite concentrates typically have a much higher activity concentration than bastnaesite concentrates as they include a ThPO₄ constituent. In the monazite concentrate, radionuclides in the ²³²Th decay chain are reported to have activities of 8 to 3000 kBq kg⁻¹, whilst radionuclides in the ²³⁸U decay chain are reported to have activity concentrations ranging from 6 to 40 kBq kg⁻¹. During the extraction process, isotopes of radium are co-precipitated with barium sulphate to form a radium-bearing by-product which has an activity concentration of around 3000 kBq kg⁻¹ of radium-228 (²²⁸Ra) and 450 kBq kg⁻¹ of radium-226 (²²⁶Ra). A second by-product with a typical activity concentration of about 20 kBq kg⁻¹ ²²⁸Ra and 3 kBq kg⁻¹ ²²⁶Ra can also occur.

1.1.3. Titanium dioxide pigment industry

The most significant raw materials containing titanium are rutile (TiO₂) and ilmenite (FeO.TiO₂), which contains monazite as an impurity. Tailings from bauxite and copper ore processing may also be sources of titanium. Rutile, and sometimes ilmenite concentrate is crushed and mixed with coal. Titanium tetrachloride TiCl₄ is obtained by chlorination in shaft furnaces. The TiCl₄ is then reduced to titanium sponge which is melted and remelted in a vacuum arc furnace.

The ore activity concentration of both ²³⁸U and ²³²Th decay chain members may range from 0.07 to 9 kBq kg⁻¹. Also, during the processing of ilmenite for the production of TiO₂ pigments, a radium-containing precipitate occurs. Activity concentrations of ²²⁶Ra in such precipitates have been reported to be around 400 kBq kg⁻¹.

1.2. Metal mining and smelting

Many metalliferous ores can contain minerals which have elevated concentrations of radionuclides. When these ores are extracted and processed the radionuclides can become concentrated in the waste streams. In addition, any large scale process which involves smelting metals at high temperatures may give rise to volatilized Pb and Po isotopes which can lead to radiological hazards to workers if they collect in flue precipitates or if workers are able to inhale them directly. Lead smelting is a notable exception because the radioactive isotopes of lead are vastly diluted by the stable lead that collects in the precipitates. Other radiological hazards may arise from the generation of slags containing elevated radionuclide concentrations.

1.2.1. Tin mining and processing

Cassiterite or tinstone (SnO₂) is the most important ore. Sulphide ores are also of commercial significance. The ore concentrate is mixed with charcoal and heated to 1000-1200°C. The tin is then remelted in a second furnace for further purification.

Production of tin can produce large volumes of slag. The main radiological hazards are the smelting slag, and the volatilized ^{210}Po which collects in dust precipitators. Typical activity concentrations of tin ore and slag in the UK were 1 kBq kg^{-1} of ^{238}U in both ore and slag, and about 0.3 kBq kg^{-1} and 0.4 kBq kg^{-1} in ore and slag respectively for the ^{232}Th chain.

1.2.2. Bauxite processing (aluminium production)

Bauxite, which contains 30 to 50% hydrated aluminium oxide, is the major source of aluminium. The original bauxite ores can contain significant levels of ^{238}U and ^{232}Th and their decay products. Typical levels of ^{238}U and ^{232}Th are in the range $0.01\text{-}9 \text{ kBq kg}^{-1}$ and $0.035\text{-}1.4 \text{ kBq kg}^{-1}$ [34], respectively, depending on the source of the bauxite ore. Bauxite is refined to produce alumina (anhydrous aluminium oxide). This processing also leads to the production of very large volumes of a material known as red mud, which can contain elevated levels of thorium. Approximately 1-6 tonnes of red mud are produced per tonne of alumina depending on the grade of bauxite (same ref). Nearly all the radioactivity in the bauxite is transferred to the red mud.

Disposal of red mud is usually carried out by spreading the material in layers over a large area to allow the material to dry. The land is then rehabilitated by mixing the waste with sand and re-vegetating the surface. Red mud has also been used as a soil conditioner [35] because of its water retention properties.

Alumina smelting does not produce substantial quantities of solid waste. The main residues are the fluoride-containing gases that are removed from the vapour discharges by scrubbing in an extraction system to remove in excess of 99% of the fluoride.

1.2.3. Copper refining

Copper ore is often found in association with other heavy metals, including silver, gold and uranium. Copper refining can produce residues containing elevated uranium concentrations. The copper is usually separated from the ore, after milling, by flotation to produce a concentrate. This concentrate is then smelted to remove volatile or less dense impurities, and then purified and electro-refined to produce high purity copper. Tailings and other associated minerals are removed at the flotation stage along with the tailings and are subject to additional processing.

Wastes consist mostly of the tailings from the flotation stage and furnace slags from the smelting stage.

The copper ore can contain significant quantities uranium. The uranium decay products ^{210}Pb and ^{210}Po tend to move with the copper concentrate during the flotation stage. These radionuclides are volatile and will vapourise at the smelting stage and may accumulate in dusts collected from off gases. Uranium tends to remain in the tailings from the flotation stage or in the slag from the copper smelter.

1.2.4. Iron and steel production

Iron ore, which consists primarily of iron oxides, is the main source of pig iron for the iron and steel industry. Iron ore is usually combined with coal or coke, and limestone to produce an iron rich porous clinker, called sinter. The sinter is added to a blast furnace, together with additional iron ore and coke. The melting process reduces the iron ore and sinter, and molten iron forms in the bottom of the furnace, while the limestone combines with the silica and

alumina impurities in the ore to form a liquid slag, which is separated from the molten iron. The molten iron is then added to an oxygen furnace where it is converted into steel.

The main waste material in the sinter plant is dust in the off-gases. The dust is removed from the gas stream by dry electrostatic precipitators. Wastes from the blast furnace smelting include slags and the dusts and fumes collected from the cleaning of the smelting off gases. Blast furnace slag is reused as landfill or road base, or in cement or concrete applications. Dust is normally disposed of as landfill.

Iron ores have geochemical properties that make them efficient scavengers of radionuclides and heavy metals. There are also trace levels of uranium in the main raw materials for iron-making, namely iron ore, coke, and limestone.

The main accumulation of radioactivity in the sinter plant is due to ^{210}Pb and ^{210}Po in the dust collected from the gas cleaning systems. Recycling of the waste gases through the sinter plant in order to reduce dust emissions can cause the concentrations of ^{210}Pb and ^{210}Po to become enhanced further.

I.3. Zircon production

Many countries produce zircon, for use in pigments, glazes, etc. Management of the residues resulting from zircon production is discussed in [36], and a detailed description of zircon production is given in [37].

The most common ores of zirconium are Zircon (ZrSiO_4) and Baddeleyite (ZrO_2), and most of the commercially useful deposits of zircon are in beach sands. Typically the sand is pre-processed in very large quantities by gravimetric and electromagnetic sorting to separate the zircon sands from the other mineral sands, which include monazite and bastnaesite. An important use of zircon sands is in the manufacture of refractory components. These are made by mixing zircon sand with alumina and sodium carbonate and smelting at high temperature. Such blocks or components are finished by grinding and polishing.

A wide range of activity concentrations are reported for zircon sand, from 0.4 to 40 kBq kg⁻¹ of ^{232}Th , and 0.2 to 74 kBq kg⁻¹ of ^{238}U

I.4. Phosphate industry

The processing of phosphate rock produces fertiliser as the major product and phosphogypsum as the main waste/residue. Phosphate rock generally contains elevated concentrations of uranium series radionuclides. During processing the uranium tends to become concentrated in the fertiliser, while radium concentrates in the phosphogypsum. Phosphogypsum has been used as a substitute for natural gypsum in building materials (plasterboard), as a cement additive, or as a soil conditioner.

Although there are few major sources of phosphate rock, many countries have facilities for processing phosphate rock to produce fertiliser, and the quantities of material handled in this process are very large, because of the widespread use of phosphate fertilisers in agriculture. Therefore the disposal of the (NORM) wastes and residues resulting from fertiliser manufacture is an important issue.

1.4.1. Mining and milling of phosphate ore

Most of the phosphate ore used is in the form of calcium phosphates ($\text{Ca}_3(\text{PO}_4)_2$) (phosphorites) and apatite ($3\text{Ca}_3(\text{PO}_4)_2 \cdot \text{CaF}_2$). Phosphorites have a typical activity concentration of natural uranium of 1.5 kBq kg^{-1} or less. Radionuclides in the ^{232}Th decay chain are typically present with activity concentration of between one or two orders of magnitude less. Some Russian deposits of apatite contain much less uranium (usually several tenths of kBq kg^{-1}) but roughly the same concentration of ^{232}Th and its progeny.

1.4.2. Phosphate ore: wet process

The wet process produces phosphoric acid (H_3PO_4) by reaction with sulfuric acid, with phosphogypsum (CaSO_4) being formed as a by-product. Alternatively, this process produces superphosphate (a combination of phosphoric acid and phosphogypsum). The phosphoric acid can be combined with ammonia (NH_3) to make ammonium phosphate, which is the basis of mixed fertilisers. Alternatively the phosphoric acid can be combined with phosphate ore to make triple superphosphates.

There is evidence to suggest that radium isotopes are more readily retained than other radionuclides in the phosphogypsum (about 80 % of the concentration in the ore). Phosphogypsum derived from central Florida rocks contains ^{226}Ra and its progeny at concentrations of approximately 0.9 to 1.3 kBq kg^{-1} .

1.4.3. Phosphate ore: thermal process

In the thermal process, the phosphate ore is crushed, mixed with silica (SiO_2 gravel) and coke, and heated to 1500°C in an electric furnace, to produce phosphorus. The elemental phosphorus is often converted into phosphoric acid, using nitric acid, for later use in the manufacture of artificial fertilizers. Fused calcium silicate slag (CaSiO_2) and ferro-phosphorous are produced as residues.

Most of the uranium (and associated decay products) originally contained in the phosphate ore are retained in the slag, giving ^{238}U and ^{230}Th concentrations of between 1 and 2.7 kBq kg^{-1} . Because of the high temperature of the process, about 95% of the relatively volatile radionuclides are released to the process air, giving typical concentrations of 50 to 500 kBq kg^{-1} of ^{210}Pb and ^{210}Po in some electrostatically precipitated dusts.

1.4.4. Fertilisers, and biosolids from wastewater treatment

The activity concentration of radionuclides in fertilizers varies widely, in part due to the different chemical compositions of fertilizers and also due to the variety of raw materials used in their production. Activities of ^{238}U vary from approximately 0.3 to 3 kBq kg^{-1} . ^{234}U and ^{230}Th are present at approximately the same activity. However ^{226}Ra and ^{210}Pb concentrations are typically between 30 % and 60 % of the ^{238}U activity concentrations (0.2 to 1 kBq kg^{-1}). ^{228}Th , ^{228}Ra (and presumably ^{232}Th) are present with activity concentrations typically between 8 and 40 Bq kg^{-1} .

Wastewater treatment plants receive through sanitary sewers a host of artificial and naturally occurring radionuclides from diverse sources. The suite of NORM radionuclides found may vary significantly depending on dischargers to the sewer system, as well as radionuclides found in ground and surface water entering the system. Processing of wastewater for public health and safety results in the production of solids termed “biosolids” which may contain a

concentration of radionuclides entering the facility. Many such facilities will use land spreading of biosolids as a soil amendment for agricultural use, or for disposal purposes. A survey and laboratory analyses, dose assessment using RESRAD-ONSITE, and guidance was developed by U.S. government agencies ([38], [39], [40]) after collecting samples from over 300 facilities across the country. As an example, concentrations of ^{226}Ra ranged from 0 to 1.7 Bq g^{-1} , with an average of 0.7 Bq g^{-1} in the samples analyzed.

I.5. Coal mining and power production from coal

Most coals (including lignite) contain radionuclides in similar concentrations to other rocks and soils. Burning of coal produces several kinds of ash. Fly ash comprises the largest component and is very fine in texture. Bottom ash is the other major component of the ash and is much coarser than fly ash. The ratio of ash volume to coal volume is approximately 1:6 for a typical coal. Most of the radionuclides in the coal remain with the ash, so the radionuclide concentration in the ash is higher than in the coal. Some of the volatile radionuclides such as polonium and lead isotopes volatilise during the burning of the coal and can be released to the atmosphere.

A 1 GW coal burning power station requires approximately 3 million tonnes of coal in one year. If this coal contains ^{238}U series radionuclides in similar concentrations to “normal” soil (approximately 30 Bq kg^{-1}) this can potentially result in the annual emission of approximately 100 GBq of the volatile radionuclides ^{210}Po and ^{210}Pb to the atmosphere.

Coal ash has been widely recycled in many countries as landfill, roadfill, as a cement extender, and in building materials.

I.6. Oil and gas extraction industry

In many oil-bearing geological formations, water is present at high temperature and under high pressure. Under these conditions radium isotopes are selectively dissolved in the water. When the oil and/or gas are brought to the surface, they are accompanied by this formation water. The sudden decrease in temperature and pressure on reaching the surface causes the dissolved radium isotopes to plate out on the inner surfaces of pipes, pumps and other equipment forming scales. These scales can contain high concentrations of radium. (up to approximately 1 MBq kg^{-1})

In many oil and gas exploration platforms the build-up of scale in pipe work and vessels constitutes a significant radiological hazard. Typically the scale is a result of mineral impurities and builds up because of the injection of incompatible water into the well, evaporation in gaseous wells, pressure changes and/or temperature drops. The material is either a barium/strontium sulphate (Ba/SrSO_4) or calcium carbonate (CaCO_3) precipitate. The chemical similarity of radium and barium leads to them selectively co-precipitating in the scale, which leads to a concentration of radium isotopes.

The main radiation protection problems associated with the scales are irradiation of staff in areas where scale is deposited, and internal contamination of those staff removing the scale. Therefore during removal processes, areas of scale should be copiously wetted, and workers equipped with a high standard of respiratory protection and other protective measures. Activity concentration is strongly dependent on site specific parameters such as the pressure and temperature variations in the facility. The activity concentration has been reported as being less than 1 kBq kg^{-1} to approximately 1 MBq kg^{-1} of ^{226}Ra , with typically rather less ^{228}Ra (depending on the age of the scale). There is anecdotal evidence that suggests the higher

concentrations ($> 100 \text{ kBq kg}^{-1}$) exist only in relatively small quantities of material (kg), and in large (tonne) quantities the concentration is around 1 to 10 kBq kg^{-1} .

I.7. Natural gas production

Natural gas can contain very high concentrations of radon (up to $100,000 \text{ Bq m}^{-3}$). This radon is released when the gas is used domestically or in industry.

I.8. Disposal of building materials

Industrial by-products and residues are used as raw materials in the building industry. When these materials contain NORM they can pose a radiological problem.

Fly ash from coal burning is used in concrete production and brick making. Phosphogypsum from the phosphate industry is used as a substitute for natural gypsum in the manufacture of plasterboard. Bottom ash from coal burning and furnace slag from metal smelters are used for road construction. These materials can contain elevated concentrations of uranium and thorium and their radioactive progeny. Potassium-40 will also be present in some materials because of the stable potassium content of the raw materials used.

I.9. Applications of radium and thorium

Rare earths, which contain elevated concentrations of uranium and/or thorium, are used in refractories, ceramics, paint manufacture, alloys, and thorium glass.

Radium is used on clock and watch hands and dials, to render the hands and dials visible in darkness.

I.10. Manufacture and applications of thorium compounds

Minerals with high concentrations of thorium oxide include monazite, thorite and thorianite. Thorium is extracted by first concentrating the minerals, then decomposing the concentrate with acids to obtain thorium salts. These are the raw materials for the production of metallic thorium.

Thorium is used in a number of materials, commonly as an additive. Examples include thoriated tungsten welding electrodes and magnesium-thorium alloys, used in jet engines, to improve the high temperature behaviour of compressor casings without significantly increasing the weight of the engine.

Thorium nitrate has been used in the manufacture of gas mantles. The production of such gas mantles used to be a widespread industry but now is much less common in Europe.

The activity concentration of thoriated tungsten welding electrodes has been variously reported but is around 100 kBq kg^{-1} of ^{232}Th and ^{228}Th . Gas mantles typically contain about 1000 Bq of ^{232}Th and ^{228}Th each. Special alloys such as those used in jets engines may have an activity of about 70 kBq kg^{-1} .

APPENDIX II. MODELS

II.1. Models used in this work

II.1.1. *COMPLY*

The COMPLY code is a computerized screening tool for evaluating radiation exposure from atmospheric releases of radionuclides. The code is designed to require only minimum input, using fixed data for environmental transport and food chain description. The COMPLY code calculates the effective dose from radionuclides released from stacks.

COMPLY includes 4 levels of complexity.

Levels 1-2 request the least amount of information; however "worst case" assumptions are used in the dose estimates.

Levels 3 and 4 request the most information, and use site specific meteorological and occupancy data instead of assuming the worst case.

Activity to dose conversion factors, fallout deposition velocities, food consumption rates and occupancy factors are fixed defaults. The total effective dose for given location is the only output.

The dose estimated by this code is used to demonstrate compliance with environmental standards and is not intended to represent actual doses to real people. More information is available in reference [23].

II.1.2. *CAP88*

CAP88 is a computer software system that is used for calculating dose from annual average releases of radionuclides to the atmosphere. The code computes radionuclide concentrations in air and their rates of deposition on ground surfaces. Atmospheric concentrations are estimated using a Gaussian plume model.

Assessments for Radon-222 include Working Level calculations. The calculation of deposition velocity and the default scavenging coefficient is also modified to incorporate current EPA policy. The deposition velocity is set to $3.5 \times 10^{-2} \text{ m s}^{-1}$ for iodine, $1.8 \times 10^{-3} \text{ m s}^{-1}$ for particulates, and 0.0 m s^{-1} for gases. The default scavenging coefficient is calculated as a function of annual precipitation. Activity to effective dose conversion factors are given as fixed default values.

The code calculates radionuclide concentrations in various foods by coupling the output of the atmospheric transport models with the food chain models.

The dose estimated by this code at any given location is used for comparison with environmental standards as required by US EPA regulations [41], and is not intended to represent actual doses to real people.

Dose estimates are applicable only to chronic exposures. More information is available in references [24] and [25].

II.1.3. PC-CREAM

PC CREAM (Consequences of Releases to the Environment: Assessment Methodology) is a suite of models and data for assessing the radiological consequences of the discharge of routine radioactive releases of aerial and liquid effluents to members of the population of concern [26]. This model was originally developed for the European Union but parts of the modelling suite have been used in other parts of the world. One feature of the model is that results can be expressed in terms of individual or collective doses.

PC CREAM consists of six modules:

- (1) ASSESSOR, the assessment program, has the central dose assessment function within the programs. Once having entered the appropriate radionuclide discharge rates, and the location and age group of the exposed individuals, the user then selects the exposure pathway(s) of interest. The assessment is then run after all of the data have been entered.
- (2) FARMLAND is a dynamic compartment model for evaluating the transfer of radionuclides through food chains following routine continuous releases to the atmosphere. The output is annual average radioactivity concentrations in the most popular foodstuffs.
- (3) PLUME is a Gaussian plume atmospheric dispersion model for calculating average radioactivity concentrations in air.
- (4) DORIS is a marine dispersion model for European waters capable of calculating radioactivity concentrations in seawater, and marine sediments.
- (5) GRANIS is a model for calculating external gamma exposure to an individual from deposited radioactivity in soil.
- (6) RESUS is a time dependent resuspension model for calculating annual average activity concentrations in air due to the resuspension of previously deposited activity.

PC-CREAM has complex file management protocols and is not simple to use. However, it is a powerful tool when used appropriately.

II.1.4. CROM

CROM is based on the generic model described in reference [27]. It is a screening model that can be used to estimate doses resulting from discharges of radionuclides to the environment from point sources.

II.1.5. RESRAD (onsite)

RESRAD is a computer code developed at Argonne National Laboratory for the U.S. Department of Energy to calculate site-specific RESidual RADioactive material guidelines as well as radiation doses and excess lifetime cancer risk to a chronically exposed on-site receptor. It is the first in a series of codes called RESRAD Family of Codes. To distinguish from other RESRAD Family of codes, the original RESRAD code is now called RESRAD (onsite) code.

A total of nine major exposure pathways are considered in the RESRAD (onsite) code (see Figure II.1):

- Direct exposure to external radiation from the contamination soil material;
- Internal exposure form inhalation of airborne radionuclides;

- Internal exposure from inhalation of radon progeny;
- Internal exposure from ingestion of:
 - Plant foods grown in the contaminated soil and irrigated with contaminated water;
 - Meat and milk from livestock fed with contaminated fodder and water;
 - Drinking water from a contaminated well or pond;
 - Fish from a contaminated pond;
 - Contaminated soil.

RESRAD was developed as a multifunctional tool and has many current and potential applications, including:

- Derivation of soil cleanup criteria for contaminated site remediation activities in compliance with DOE Order 5400.5 and other regulatory requirements;
- Compute potential radiation exposures in terms of annual doses and lifetime cancer risks to workers or members of the public resulting from residual radioactive materials in soil;
- Estimate future concentrations of radionuclides in various media (air, surface water, and groundwater) resulting from contamination in soil;
- Support an ALARA analysis or a cost benefit analysis for use in the decision making process concerning decontamination and decommissioning;
- Prioritize budget and effort in collecting data on soil properties and hydrogeological properties that affect the environmental distribution of radioactive waste and consequently, the decision on waste management.

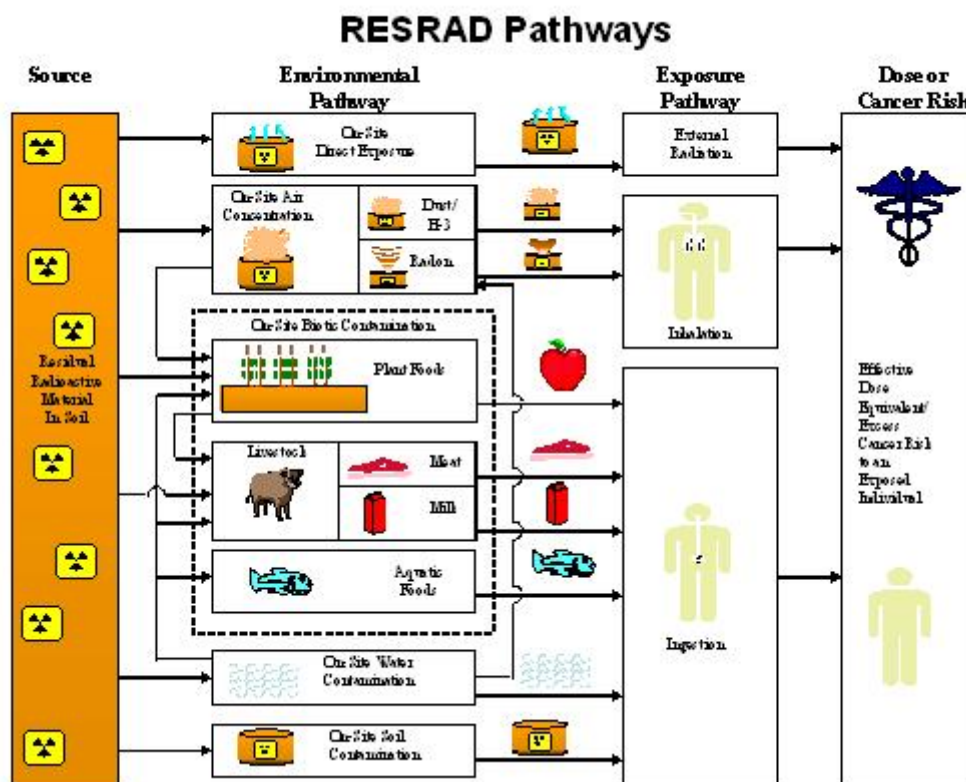

Fig. II.1. A diagrammatic summary of the pathways considered in RESRAD.

The RESRAD model can be used to handle situations such as buried waste and landfill (uncovered waste) ([28], [29]). It has limited source region geometry, and is not designed to predict off-site impacts (see RESRAD-OFFSITE descriptions in Appendix II.1.6). In spite of this limitation, the model is very useful, as it can be used to make conservative estimates of off-site impacts. The model handles a wide range of nuclides, and allows users to change the cut-off half-life for setting short-lived daughters in equilibrium with their parent radionuclide.

II.1.6. RESRAD-OFFSITE

II.1.6.1. Code development

RESRAD-OFFSITE was developed to estimate the radiological consequences to a receptor located either onsite or outside the area of primary contamination. It is an extension of the RESRAD (onsite) code. RESRAD-OFFSITE calculates radiological dose and excess lifetime cancer risk and outputs radionuclide concentrations in the environment and derives soil cleanup guidelines ([30], [31]).

Development of the code was sponsored by the DOE Office of Health, Safety and Security, and the Office of Environmental Management, with support from the U.S. Nuclear Regulatory Commission. The code was developed by Argonne National Laboratory (Argonne). Code and version control are currently maintained by DOE through Argonne as part of the RESRAD family of codes.

II.1.6.2. Exposure locations considered

RESRAD-OFFSITE considers initial contamination in soil. There may be a clean cover layer on top of it and up to five partially saturated layers below it. The code has a capability to model the radiation exposure of an individual who spends time directly above the primary contamination (onsite) and away from the primary contamination (offsite).

An individual might spend some time in buildings that are located either onsite or offsite. That individual could consume plant- and animal-based foods that are grown onsite or derived from offsite agricultural fields that are contaminated by material from the primary contamination. The water the individual drinks and uses can be drawn from a well or a surface water body located onsite or offsite. For a surface water body, it can also be the source where the individual obtained aquatic food for consumption.

II.1.6.3. Pathways

Nine exposure pathways are considered in RESRAD-OFFSITE:

- direct exposure from contamination in soil;
- inhalation of particulates and radon;
- ingestion of plant foods;
- ingestion of meat;
- ingestion of milk;
- ingestion of aquatic foods;
- ingestion of water, and
- incidental ingestion of soil.

II.1.6.4. Exposure scenarios considered

By selecting different pathways, RESRAD-OFFSITE can be used to simulate various exposure scenarios. Example scenarios that can be modelled include:

- rural resident farmer;
- urban resident;
- industrial worker; and
- recreational scenarios.

These features are represented graphically in Figure II.2.

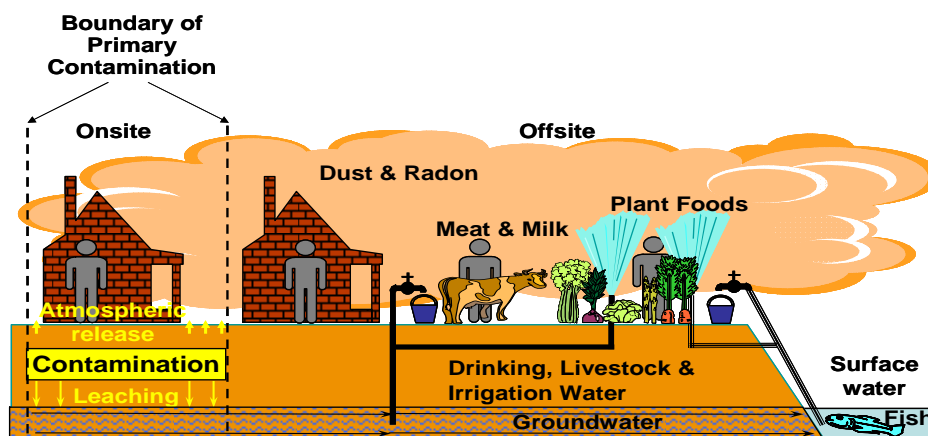

Fig. II.2. Graphic representation of the RESRAD-OFFSITE conceptual model.

II.1.6.5. Main features of the RESRAD-OFFSITE package

The main features of the RESRAD-OFFSITE package are:

- the package is user friendly with context-specific help and quick access to the users' guide in pdf format;
- there is a map interface that allows the primary contamination and the offsite areas to be specified and displayed on a map of the region of interest;
- the package includes all the exposure models in RESRAD (onsite), with minor changes. Extends these models to offsite locations to consider offsite exposure;
- different exposure scenarios can be specified by activating or suppressing pathways and by modifying usage and occupancy parameters;
- the code uses numerical methods to compute media concentration, dose, and risk progressively over time;
- text output reports are generated following each run, providing a listing of all input parameters, the maximum dose and the minimum soil guidelines;
- the package uses the ICRP38 database of radionuclides.

II.1.6.6. RESRAD-OFFSITE Data and Uncertainty Analysis Input Screen

- For each user-specified time, the text reports list doses, soil guidelines, and health risks by radionuclide and pathway;
- Generates temporal plots of dose, risk, concentration, soil guidelines and dose/source ratio;
- Can perform sensitivity and probabilistic analysis to study the influence of input parameters and generate graphic results for the analysis;
- Database includes the FGR11 [42], FGR12 [43], and ICRP72 [44] age specific dose factors, as well as FGR13 [45] and HEAST [46] morbidity or mortality slope factors. Allows users to choose dose and risk factors or to set up their dose/risk library;
- Can accept input of temporal data of (1) radionuclide concentrations in the primary contaminated zone and the mixing layer, (2) radionuclide fluxes to the groundwater, to the surface runoff, and to the atmosphere, (3) the dimensions of the cover, mixing layer, and primary contamination, and (4) the eroded soil mass.

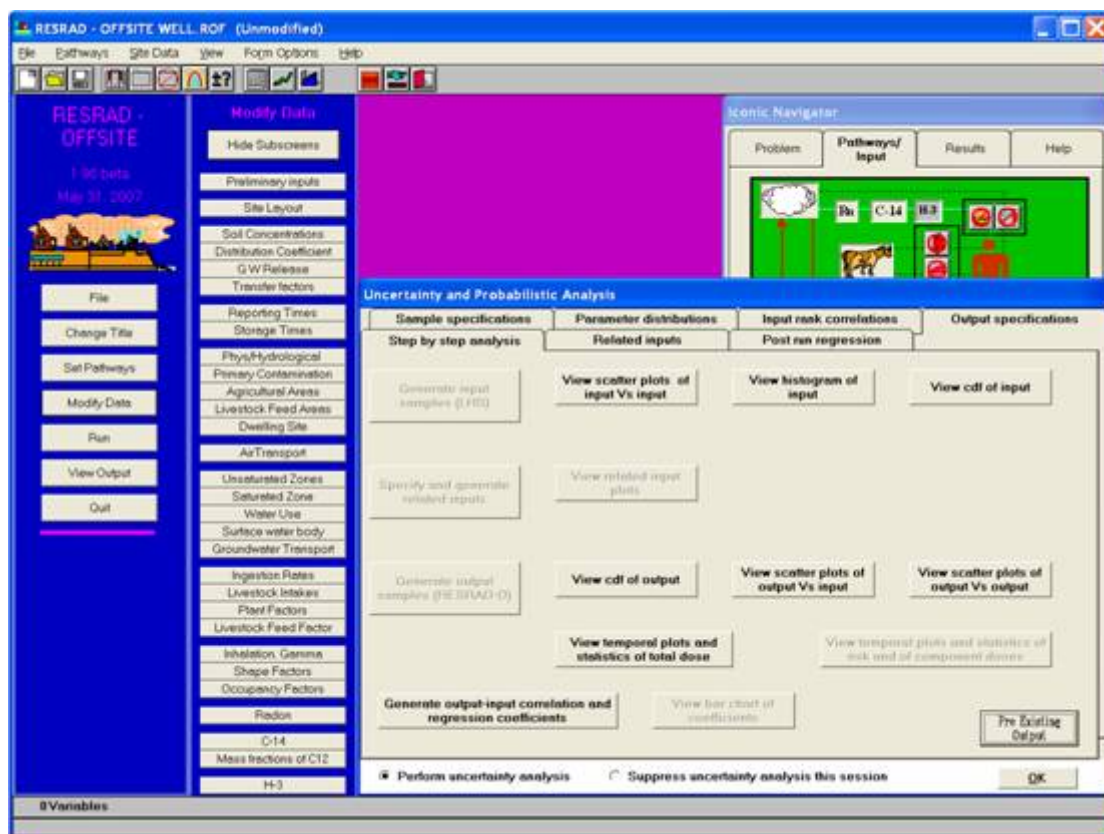

Fig. II.3. The data and uncertainty analysis input screen.

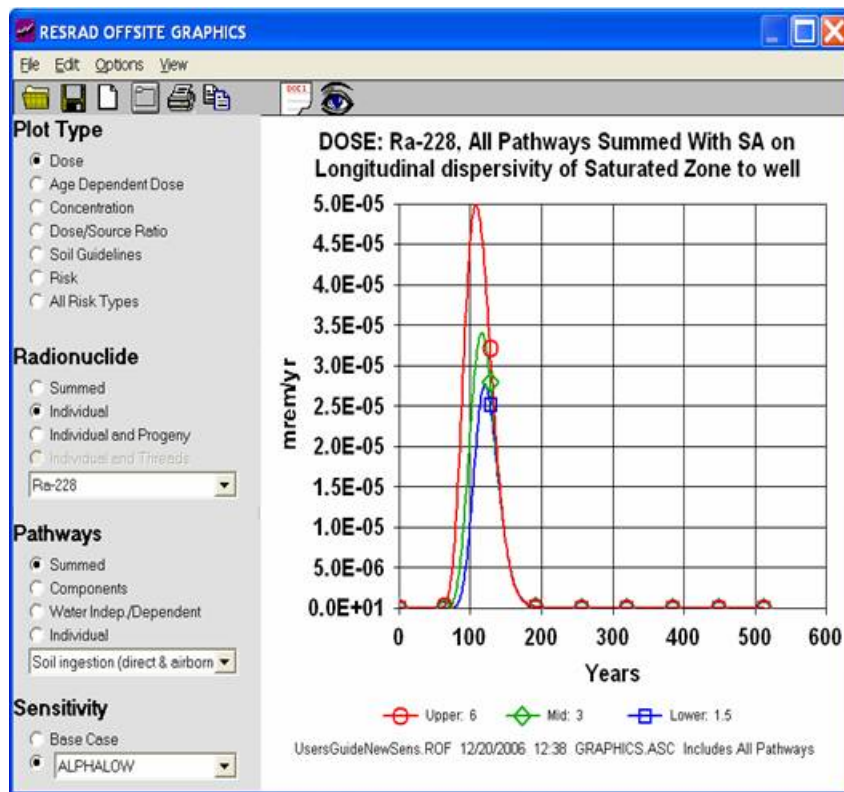

Fig. II.4. A typical RESRAD-OFFSITE sensitivity analysis result screen.

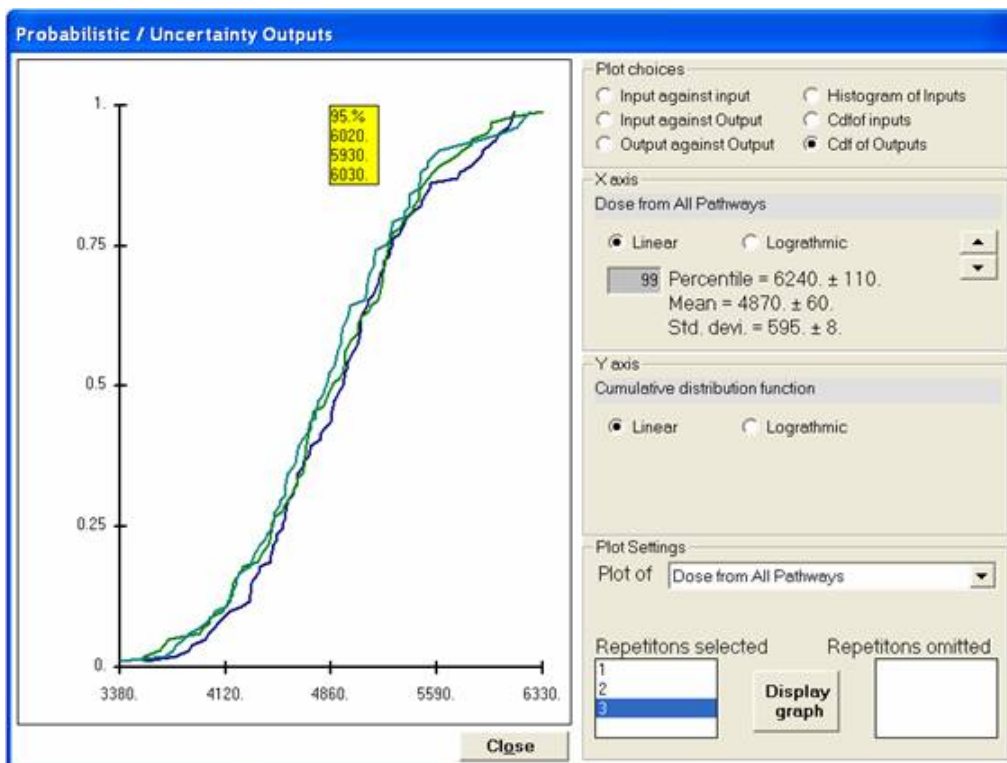

Fig. II.5. RESRAD-OFFSITE Probabilistic Analysis result.

II.1.6.7. New Models/Major Improvements Over RESRAD (Onsite)

- Air dispersion (Gaussian Plume) model to calculate concentrations at downwind locations;
- Groundwater transport model includes consideration of dispersion horizontally and vertically to calculate concentration at a down gradient off-site location;
- Off-site accumulation of radionuclides in soil from irrigation and in surface water from runoff;
- Graphical map interface for specification of receptor and agricultural field locations;
- Choice of two dwelling locations (onsite, offsite);
- Four agriculture fields at different locations;
- Well and surface water body can be located off the centerline of the groundwater plume; and
- Improved user interface for both deterministic and probabilistic analysis.

II.1.6.8. Types of Releases From Primary Contamination

The code considers three types of releases that lead to the contamination of the offsite locations. A rate-controlled release is used to model the quantity of contaminants that are removed by water that flows down through the primary contamination (leaching). A dust release-equilibrium model is used for the atmospheric release. The material that is eroded by surface runoff is modelled as a release to the surface water body. The atmospheric and runoff releases are effective once the surface soil layer becomes contaminated. Accumulation of radionuclides at the offsite locations are considered through deposition and irrigation.

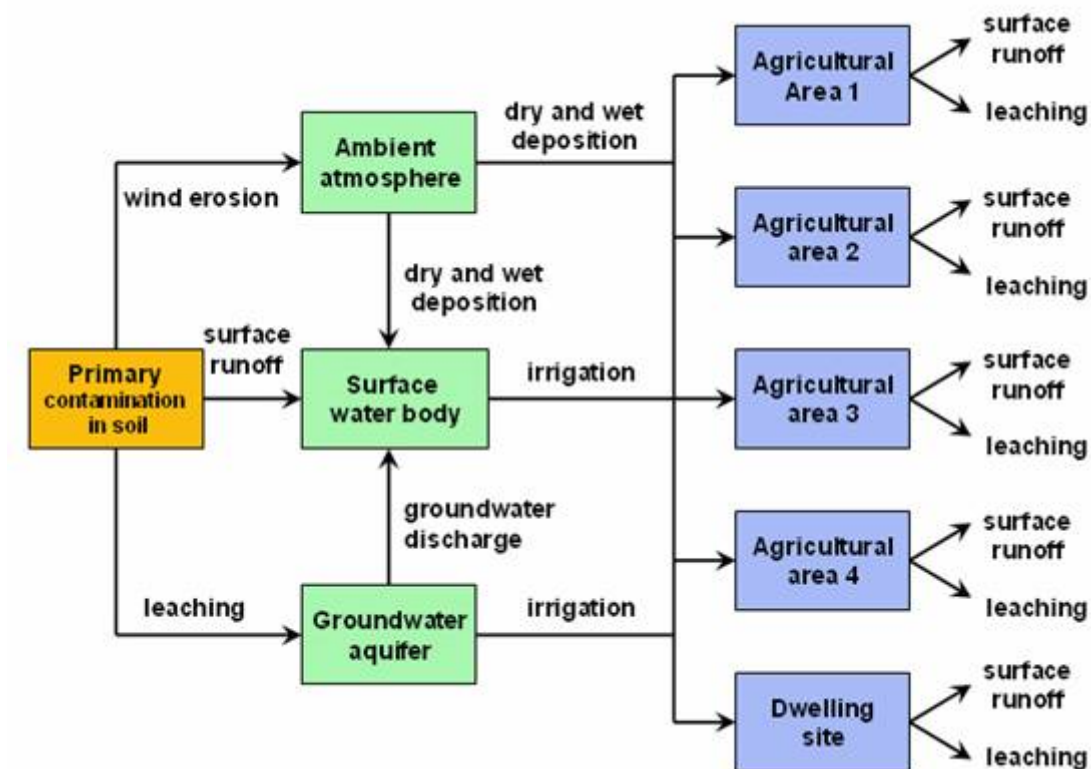

Fig. II.6. Environmental transport considered in RESRAD-OFFSITE.

II.1.6.9. Groundwater Transport In RESRAD-OFFSITE

In addition to convection and dispersion in the liquid phase, the RESRAD-OFFSITE groundwater transport model also considers the decay of the parent radionuclide, the ingrowth of progeny radionuclide(s), and their respective retardation due to sorption/desorption in the solid phase. Numerical analysis methods were employed to solve the differential equations that characterize the behaviour of radionuclides. To increase the precision of the calculation results, an option of further dividing each unsaturated zone and saturated zone to smaller sub-layers is provided. The use of sub-layers, although it would increase the precision of the results, would also increase the calculation time.

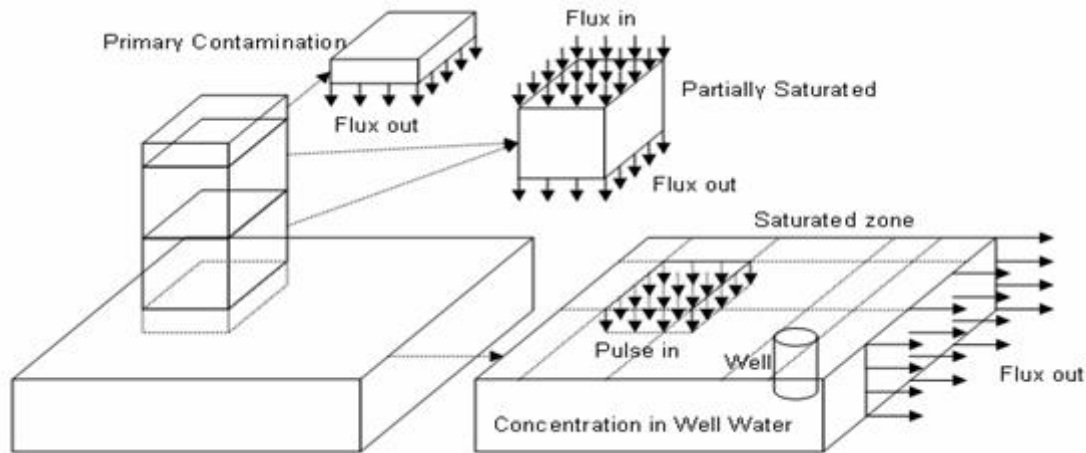

Fig. II.7. Schematic representation of the RESRAD-OFFSITE leaching and groundwater transport models.

II.1.6.10. Atmospheric Transport Model In RESRAD-OFFSITE

- Gaussian plume model based on area source release was incorporated to calculate air concentrations at offsite locations;
- Plume-rise model was employed to estimate the buoyancy-induced rise;
- Standard Pasquill-Gifford dispersion coefficients or the Briggs dispersion coefficients are accepted;
- Dry and wet deposition of the plume content are considered for vapour or particulate radionuclides; and
- Spatial integration over the area of consideration is performed via the use of spacing grids to obtain the average air concentration.

II.1.6.11. Availability of RESRAD-OFFSITE

RESRAD-OFFSITE is available free of charge and can be downloaded from the RESRAD Web site (<http://www.evs.anl.gov/resrad>) after completing the on-line registration. The RESRAD Web site contains useful information including the latest version of RESRAD family of codes, training workshop schedules, frequently asked questions, and many supporting documents for download.

II.1.7. DOSDIM + HYDRUS

Two different models were used to calculate the impact of the NORM waste:

DOSDIM (Dose Distribution Model) is a compartmental type of model of the biosphere, partly dynamic, depending on the time frame and on the exposure pathways considered. It has been expanded by the addition of a module which calculates radon concentrations in the air from large area sources. The calculations in this module are based on the equations used in the IFDM (Immission Frequency Distribution Model), which is a multi source Gaussian dispersion model developed to calculate ground level concentrations for pollutants released from point and area sources [47]. The DOSDIM model has been used several times in international biosphere model verification studies (see Table II.2).

Table II.1. List of international programs to which DOSDIM has contributed.

Programme name	Description	Reference
BIOMOVS	Scenario A4 – Multiple Model Testing using Chernobyl Fallout Data	[15]
VAMP	Multiple Pathways Assessment Working Group: Validation of models using Chernobyl fallout data, from the Central Bohemia region	[10]
VAMP	Validation of models using Chernobyl fallout data, from southern Finland	[12]
BIOMASS	Remediation Assessment Working Group (Theme 2):Testing of environmental transfer models using data from the remediation of a radium extraction site	[16]

For the modelling of the transport of the radionuclides in the variably saturated medium under the waste, the HYDRUS 1D programme has been used in combination with HYDRUS 2D. Both models can calculate water and solute transport in the saturated and unsaturated zone. The HYDRUS computer code numerically solves the Richards equation for variably-saturated water flow and convection-dispersion type equations for heat and solute transport. The program may be used to model water and solute movement in unsaturated, partially saturated, or fully saturated porous media. The governing flow and transport equations are solved numerically using finite element schemes [48], [49]. For this work, the one-dimensional version HYDRUS 1D is used for the modelling of the transport of the radionuclides through the vadose zone (unsaturated) under the waste, into the aquifer (saturated zone). The concentrations of the radionuclides in the aquifer at the location of the exposure point (a well at the house), are then calculated with HYDRUS 2D using the output values from HYDRUS 1D version as input.

II.1.8. PRESTO-CPG ver. 4.2

PRESTO (Prediction of Radiological Effects Due to Shallow Trench Operations) is a computer package for evaluating radiation exposure from contaminated soil layers, including waste disposal, soil cleanup, agricultural land application, and land reclamation.

The package is designed to calculate the maximum annual effective dose to a critical population group in several scenarios:

- near surface disposal trench containing low-level radioactive waste,
- residual radionuclides remaining in soil layers after cleanup,
- agricultural land application of NORM waste, and
- stripped land reclamation with applied NORM waste.

The models in the package simulate the transport of radionuclides in air, surface water, and groundwater pathways, and evaluate exposures through ingestion, inhalation, immersion and external exposure pathways. To avoid overly conservative results, the following approaches are used:

- a dynamic approach for the infiltration sub-model;
- a multi-phase leaching concept for the release sub-model;
- realistic transition flow from vertical transport reach to horizontal transport reach for the groundwater sub-model; and
- plausible scenario assumptions for the well mechanics sub-model.

The model of radionuclide migration assumes the same K_d values for parent and daughter radionuclides in decay chains. The waste is separated from the aquifer by one unsaturated soil layer. Simulation time is limited to 10,000 years.

More information is available on <http://www.epa.gov/radiation/assessment/presto.html>

II.1.9. AMBER

AMBER 5.1 is a generic Windows based compartment modelling package¹ designed as a flexible tool that allows users to implement their own dynamic compartment models to represent the migration, degradation and fate of contaminants in an environmental system. The code enables fully probabilistic and time-dependent models to be represented.

AMBER was considered by two participants in this project who both concluded that, without experience of using the code, considerable time was needed to develop the models suitable to represent the scenarios in AMBER. It was noted, however, that this approach to modelling has considerable potential and flexibility, because the package provides a wide range of modelling functions and tools, together with a choice of Laplace and time-dependent equation solvers. However, the onus is on the user to develop appropriate models for a specific application. An example of the use of AMBER is given in [50].

II.2. Other models

II.2.1. RESRAD-BUILD

RESRAD-BUILD is a model for analysing the radiological doses resulting from the remediation and occupancy of buildings contaminated with radioactive material. Features of the model include:

- calculation of doses for external exposure, inhalation of dust and radon, and ingestion of soil/dust pathways;
- up to 10 sources and 10 receptors can be modelled;
- point, line, plane, or volume source geometry;
- up to three compartments can be used to simulate the building structure;
- radioactive contamination on surfaces or in building materials;

¹ AMBER is developed and supported by Enviros Consulting Limited and Quintessa Limited. More information is available at www.quintessa.org/amber, together with a freely downloadable demonstration version.

- building occupancy (residential use and office worker) and building remediation (decontamination worker and building renovation worker) scenarios.

The code can perform uncertainty/probabilistic analysis [51], [52]. It incorporates default parameter distributions (based on national average data) for the selected parameters. The code can provide analysis results as text reports, interactive output, and graphic output. The results of an uncertainty analysis can be used as a basis for determining the cost-effectiveness of obtaining additional information or data on input parameters/variables [53].

The RESRAD-BUILD code allows users to calculate the time-integrated dose over the exposure duration at user-specified times. The instantaneous dose over the exposure duration can be calculated by setting the time integration point to one. The RESRAD-BUILD database includes inhalation and ingestion dose conversion factors from reference [42], direct external exposure and air submersion dose conversion factors from reference [43], and radionuclide half-lives from reference [54].

RESRAD-BUILD Version 3 incorporates many improvements made since the code was first released in 1994. A table for easier input and review of source/receptor shielding properties has been added. The code now has an improved 3-D display to illustrate source-receptor locations. Users can now input radionuclide activity in SI units, and the resultant dose can also be reported in SI units. The help file in the code and the table of contents of the text report have been improved and are now much easier to use and navigate. This latest version of the RESRAD-BUILD code can be run only on computers with Windows operating systems (Windows 95, 98, NT, XP, and 2000).

The RESRAD-BUILD code is part of the RESRAD family of codes, which now has its own Web site (<http://www.ead.anl.gov/resrad>). The site has information on updates to the codes, and users can download the most recent release of the code of interest. The site also contains information on upcoming training workshops and links to many documents relevant to application of the particular code. Users can get technical assistance via e-mail (resrad@anl.gov). Documentation for several of the RESRAD family of codes, including RESRAD-BUILD Version 3, can also be found on the RESRAD Web site.

II.2.2. FRAMES

FRAMES² (version 2.x) (Framework for Risk Analysis Multimedia Environmental Systems) is a Windows-based software system that allows several separate environmental transport and risk assessment models, along with user developed databases, to function together flexibly to accommodate user designed exposure scenarios and pathways. The program provides a common application programming interface to enable data transfer between models, either those provided with the software, or incorporated by the user. It also provides a way to perform sensitivity and uncertainty analysis on data from all kinds of deterministic models.

For each scenario the user selects the required models and databases. Once the model is set up for the scenario, the user can change a parameter or database and rerun the model. The package allows problems involving radionuclides, chemicals, ground water and surface water

² FRAMES was developed by the Pacific Northwest National Laboratory (PNNL) under the sponsorship of the U.S. Environmental Protection Agency (EPA) Offices of Radiation and Indoor Air (ORIA) and Research and Development (ORD), U.S. Army Corps of Engineers (ACOE) Engineer Research and Development Center (ERDC), U.S. Nuclear Regulatory Commission (NRC), U.S. Department of Energy (DOE), and American Chemistry Council (ACC).

flow, and atmospheric dispersion in an integrated operating package. No specialized programming knowledge is needed. This means that the user can concentrate on the environmental problem, rather than program development.

An advantage of the software is its capability to provide risk and dose assessment for radiation and/or hazardous substances in environmental settings using its multiple "medium-specific" models (for example: air, water, and human impacts) as well as a database of chemical properties with associated environmental parameters to solve risk analysis problems. The software, tutorial, and documentation can be found at <http://mepas.pnl.gov/earth/index.stm>

FRAMES was examined by one participant in this study who found that while extremely flexible and potentially useful for NORM site modelling, the requirements for inputting significant amounts of field analytical data can limit its application to locations which have been very well sampled. While the tutorial and other supporting materials are helpful, the lack of default selections for many data input screens may hinder inexperienced users.

II.2.3. GENII

GENII has been developed by the U.S. Department of Energy. Version 2 was developed in 2002, and incorporates improved transport models, exposure options, dose and risk estimation, and user interfaces. The software was peer reviewed in 2003, and can be downloaded from the web. The user can change specific parameters.

A version called GENII-NESHAPS was also developed in 2002 for demonstrating compliance with the dose limits specified in reference [41] for radionuclides. This version incorporates the internal dosimetry models recommended in references [44], [55] and [56], and the radiological risk estimating procedures of reference [57] into updated versions of existing environmental pathway analysis models. GENII-NESHAPS functions within FRAMES, so that GENII can run in conjunction with and provide inputs to related software.

The GENII-NESHAPS system calculates radiation doses from chronic atmospheric releases, using a chronic (annual average) plume model, which allows use of an effective stack height or calculation of plume rise from buoyant or momentum effects (or both).

The system calculates health risks to individuals or populations by applying appropriate risk factors to either the effective dose, the effective dose equivalent, or the organ dose. It also estimates cancer risk to specific organs or tissues using risk factors from reference [57].

GENII-NESHAPS allows the user to enter data via an interactive, menu-driven interface. Default exposure and consumption parameters are provided for the maximally exposed individual. The program allows radionuclide source term information to be entered in formats appropriate for different exposure scenarios. The model considers decay of parent radionuclides and in-growth of radioactive decay products prior to the start of the exposure scenario for either basic or derived concentrations. The system works sequentially on individual decay chains, which allows unlimited numbers of radionuclides, including the source term and accumulated decay products, to be processed in a single run.

GENII-NESHAPS uses a radial grid, which allows both the distance and direction from the source to target individuals and populations to be considered. The model handles chronic releases to air from both ground level and/or elevated sources. The exposure pathways incorporated in the model include direct exposure from surface sources (soil) and air (semi-infinite and finite cloud geometries), and inhalation and ingestion.

GENII is no longer supported by the U.S. EPA, and is not currently available for download on the software writer's website.

II.2.4. ROOM

The methodology used in the ROOM model is described in [58]. The model estimates indoor gamma doses from building materials, using the activity concentration of natural radionuclides in the building materials and geometrical and structural information of the modelled room (wall dimensions, etc) as input data.

II.2.5. MILDOS

MILDOS software is used by the U.S. Nuclear Regulatory Commission (NRC) to estimate radiological doses and risks from uranium mining licensing activities. This software package has been updated to reflect changes in four areas: regulations, in-situ leaching (ISL) mining technologies, graphical user inter-faces, and Internet software distribution technologies. Users can now specify ISL processes through a Windows object-based geographic information system interface that incorporates updated dose assessment methodologies. The MILDOS code and documentation are available for downloading at no cost through the MILDOS web site from Argonne National Laboratory.

II.2.6. MICROSSHIELD

MICROSSHIELD is a photon/gamma ray shielding and dose assessment program that is used for designing shields, estimating source strength from radiation measurements, minimizing exposure to people, and teaching shielding principles. The model is interactive and utilizes input error checking. Integrated tools provide graphing of results, material and source file creation, source inference with decay, projection of exposure rate versus time as a result of decay, access to material and nuclide data, and decay heat calculations. The model, available for purchase from Grove Software. Inc., has been used by the oil and gas industry, and other industries which have sought to evaluate direct exposure from contaminated equipment and materials.

II.3. Screening Models

II.3.1. Soil Screening Guidance for Radionuclides

This calculator was developed as a screening tool by the U.S. Environmental Protection Agency to help standardize and accelerate the evaluation and cleanup of soils contaminated with radioactive materials at sites with future potential residential land use. It is an Internet based calculator to determine risk-based, site specific, screening levels for radionuclides in soil to identify areas needing further investigation. However, it can provide a relatively simple means of determining if an area of contaminated ground exceeds the risk determined acceptable for radiation exposure by the national authority.

The model can be found on the Internet at: http://rais.ornl.gov/rad_start.shtml.

A user begins calculations by entering what is considered the acceptable risk level for exposure to radiation (e.g., national standards such as mortality of 1 in 10,000 from cancer from long-term exposure) which serves then as a limit for the maximum concentration of the radionuclide(s) present in the soil. After choosing the radionuclides which are known to be present at a site, the user determines the potential pathways of exposure, and can enter some

site specific data used by the calculator to then determine the soil concentration limit for each pathway at the site.

The model is easy to use, requires a minimum of data and offers default values if specific values have not been determined, has good accompanying documentation [59], and provides a simple means to assess contamination at a site.

II.3.2. Preliminary Remediation Goals for Radionuclides

This screening model was developed by the U.S. Environmental Protection Agency to set preliminary cleanup goals for a site which has been more extensively evaluated and sampled through a field investigation. It is an Internet based calculator found at http://epa-prgs.ornl.gov/radionuclides/prg_search.shtml

In order to set radionuclide-specific preliminary remediation goals in a site-specific context, assessors must answer fundamental questions about the site: information on the radionuclides that are present onsite, the specific contaminated media, land-use assumptions, and the exposure assumptions behind pathways of individual exposure. The calculator provides the ability to modify the standard default exposure parameters to calculate site-specific preliminary remediation goals. The calculator is relatively easy to use, provides default values if specific values have not been determined through site investigation, has a well documented user guide, and offers a number of risk assessment scenarios for evaluation. However, one drawback for international use is that particulate emissions require selection of a climatic zone and the only choices offered are U.S. cities; this may be circumvented if an international site has similar characteristics for the U.S. area.

II.3.3. RCLEA

RCLEA (The Radioactively Contaminated Land Exposure Assessment Methodology) is DEFRA's (U.K. Government Department for Environment, Food and Rural Affairs) recommended approach for the exposure assessment of a site under the extended Part 2A regime for managing contaminated land in the UK.

Information on RCLEA is available on <http://www.rclea.info/index.htm>

'RCLEA calculates potential doses for comparison with UK regulatory criteria. It can also be used to calculate 'Guideline Values' in terms of radionuclide concentrations if reliable measurements are not yet available. In addition to specifying radionuclides present (and concentrations, if known), initial generic calculations simply provide the user with four basic options to select from:

- reference land uses, including residential (with or without home-grown vegetables), allotments and commercial/industrial use;
- building type (timber framed or brick);
- age of the exposed individual (adult, infant or child); and
- sex of the exposed individual (male or female).'

II.3.4. BPRG

BPRG (Preliminary Remediation Goals for Radionuclides in Buildings) is a screening model calculator developed by the Oak Ridge National Laboratory for the U.S. EPA. It utilizes an Excel spreadsheet designed to evaluate preliminary remediation goals for contaminated buildings. It is a risk assessment and decision making tool for contaminated buildings. The contamination can result from radioactive material used in construction materials or brought into or manufactured in the building. The software enables a user to evaluate the risks posed to either indoor workers in an industrial building, or a member of the public in a contaminated house. Sources of exposure evaluated are direct external exposure (gamma), deposited dust (ingestion and external exposure) and ambient air (inhalation and submersion). A user may enter site-specific data as well as use model supplied default values if specific parameter values have not been determined previously. Outputs include preliminary estimates of remediation levels for the subject building in units of both activity per unit area and activity per unit mass. The model can be found at <https://epa-bprg.ornl.gov/>

APPENDIX III. SPECIFICATIONS FOR THE HYPOTHETICAL SCENARIOS

III.1. Guidance for modellers

Modellers who were interested in testing models using these hypothetical scenarios were asked to carry out a specific series of tests to facilitate intercomparison of results. The requests were:

- (1) To run the model using the wind rose given in the scenario specifications, and then repeating the calculation with the wind rose rotated 90, 180 and 270 degrees.
- (2) To use the data specified in the scenario tables, to enable the model outputs to be directly compared with each other;
- (3) To calculate radionuclide concentrations in air, soil, drinking water and foodstuffs;
- (4) To calculate committed effective dose to the individuals specified in the scenarios;
- (5) To calculate the model outputs at times of 10 years, 100 years, 1,000 years, and 10,000 years after placement of the waste;
- (6) To repeat the calculations using local data if such data are available, and send in the results, as this will provide a measure of the sensitivity of the model to changes in input data;
- (7) To repeat the calculations for the area source and area source plus river scenarios for the situation where there is no cover material in place. Use a resuspension factor of $k(T) = 10^{-5} / T \text{ } 10^{-5} \text{ m}^{-1}$ (with T = time after placement of the waste in days) and a total deposition velocity of 0.01 m s^{-1} .

III.2. Hypothetical point source scenario

III.2.1. Site Description

The site for this scenario is intended to represent a mineral smelting plant with a single chimney stack with an effective height of 100 m.

The plan of the site is shown in Figure III.1. This figure also shows the reference direction for the wind rose, the direction of groundwater flow, and the locations of two houses, at distances of 300 m and 1000 m from the edge of the waste pit.

The annual wind rose data and atmospheric stability data are shown in Table III.1 and Table III.2 respectively.

The stack discharge data are shown in Table III.3.

The dietary data are shown in Table III.4, and occupancy data are shown in Table III.5.

In this hypothetical point source scenario, assume that the time spent outdoors is spent in the field surrounding the house occupied by the person whose annual dose is to be estimated.

Partition coefficients (K_d) are given in Table III.6.

For soil, use values of porosity and effective porosity of 0.4 and 0.2 respectively (if applicable).

The aim is to estimate the annual doses to residents of the two houses shown in Figure 8, up to 50 years after the beginning of the stack discharge, assuming that each person spends 16

hours indoors and 8 hours outdoors (see Table III.5). Assume that a resident of House #1 works only in Field #1 and that a resident of House #2 works only in Field #2.

Assume that the stack discharge is continuous over the 50 year period.

At each house, drinking water is supplied from a well situated at the location of the house. Irrigation water is drawn from an uncontaminated source.

NOTE: the parameter values given in this report should not be considered as “standard” values for all NORM problems. They have been selected, for this report only, to facilitate the comparison of results and testing of models. For real scenarios, site-specific data should be used wherever possible.

III.2.2. Data tables and figures for hypothetical point source scenario

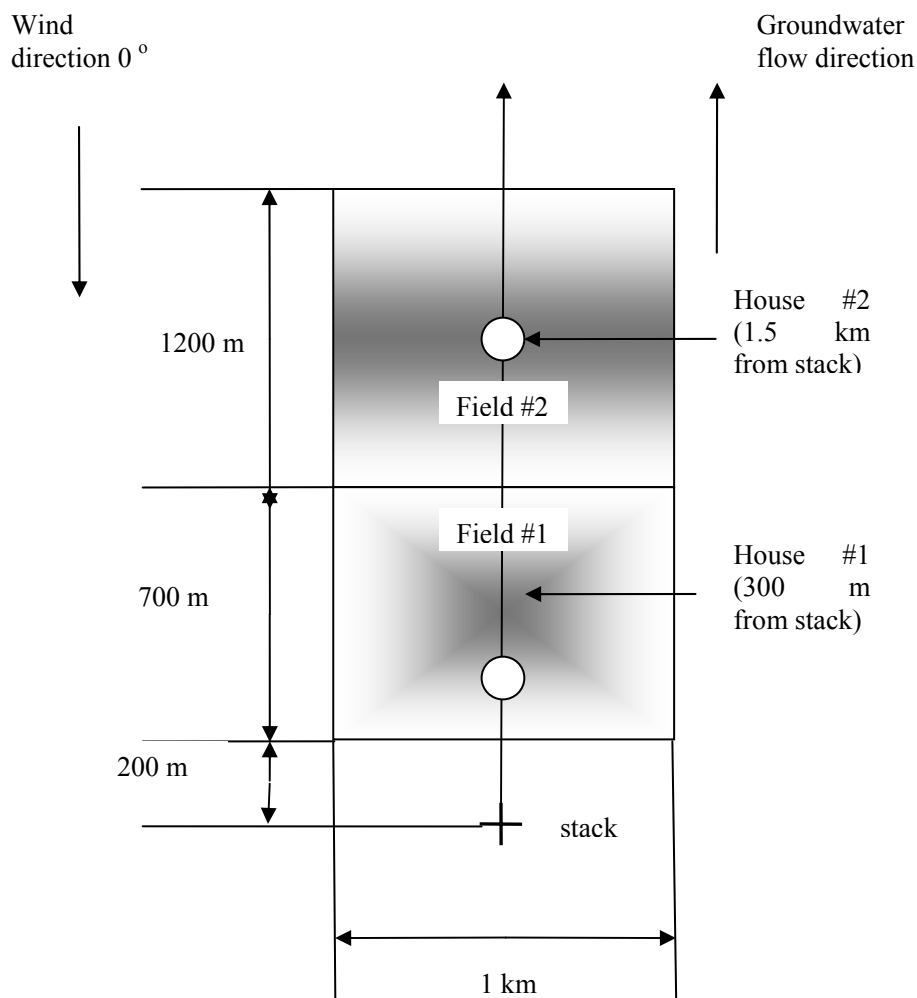

Fig. III.1. Plan of the site for the point source discharge scenario.

Table III.1. Annual wind rose data.

Sector	Wind Direction	Frequency (%)
1	345° - < 15°	4.6
2	15° - < 45°	5.4
3	45° - < 75°	7.6
4	75° - < 105°	5.4
5	105° - < 135°	3.8
6	135° - < 165°	7.4
7	165° - < 195°	14.1
8	195° - < 225°	20.3
9	225° - < 255°	13.3
10	255° - < 285°	7.5
11	285° - < 315°	6
12	315° - < 345°	4.1

Table III.2. Annual atmospheric stability and wind speed data.

Pasquill stability category	Frequency (%)	Mean Wind Speed (m s ⁻¹)
A	0.5	1
B	0.5	1.5
C	4	2.5
D	28	5
E	38	8
F	27	6
G	2	4

Table III.3. Stack discharge data for the point source scenario.

effective stack height	100	m
air discharge rate	100	m ³ s ⁻¹
²²² Rn discharge rate	10 000	Bq s ⁻¹
²¹⁰ Pb discharge rate	100	Bq s ⁻¹
²¹⁰ Po discharge rate	100	Bq s ⁻¹

Table III.4. Dietary data.

drinking water	well	400	L y ⁻¹
irrigation	river	1	L m ⁻² d ⁻¹ for 100 days
cattle	river	60	L d ⁻¹
sheep	river	6	L d ⁻¹
diet	fish	5	kg y ⁻¹
	grains + grain products	80	kg y ⁻¹
	fruits + juices	80	kg y ⁻¹
	vegetables	70	kg y ⁻¹
	meat + sausages	40	kg y ⁻¹
	milk + milk products	90	kg y ⁻¹
	root crops without tubers	70	kg y ⁻¹
	tubers	90	kg y ⁻¹

Table III.5. Occupancy data.

indoors – sleeping	8	h
indoors - light exercise	8	h
outdoors - light exercise	4	h
outdoors - heavy exercise	4	h

Table III.6. Partition coefficient KD of radionuclides in soils (L kg⁻¹) [1].

Nuclide	Soil type			
	Sand	Loam	Clay	Organic
Ac	450	1500	7400	5400
Bi	120	400	670	1500
Pa	540	1800	2700	6600
Pb	270	16000	540	22000
Po	150	400	2700	6600
Pu	540	1200	4900	1800
Ra	490	36000	9000	2400
Th	3000	3300	5400	89000
U	33	12	1500	400

III.3. Hypothetical area source scenario

III.3.1. Site Description

The site is an area source consisting of a layer of contaminated waste 1000 m long by 1000 m wide by 10 m thick, with a cover layer of soil 2 m thick.

The plan of the site is shown in Figure III.2. This figure also shows the reference direction for the wind rose, the direction of groundwater flow, and the locations of three houses, one in the centre of the waste pit, and the other two at distances of 200 m and 1000 m from the edge of the waste pit.

A diagrammatic representation of the vertical layout of the waste site is shown in Figure III.3. Below the waste is a 3 m thick unsaturated layer made up of a mixture of sand and clay. Below the unsaturated layer is a saturated layer of sand 15 m thick.

III.3.2. Data

Meteorological data: the annual wind rose data and atmospheric stability data are shown in Table III.7 and Table III.8 respectively.

Human dietary data: dietary data for humans are shown in Table III.9. It is assumed that the contaminated fraction for each type of food is 0.5.

Occupancy data: Occupancy data for the residents of the three houses are shown in Table III.10.

Animal dietary data: dietary data for beef cattle are given in Table III.11.

Water usage: At each house, drinking water for humans is supplied from a well situated at the location of the house. The consumption rate for drinking water is given in Table III.9.

Drinking water for cattle and sheep is drawn from an uncontaminated source. Drinking water rates for cattle and sheep are given in Table III.11.

Irrigation water is drawn from an uncontaminated source, and applied at the rate of 1 L m⁻² d⁻¹ for 100 days per year.

Water used for agriculture is also drawn from an uncontaminated source.

Plant and crop transfer factors: transfer and uptake factors for plants and crops (fruit, grains, leafy and non-leafy vegetables, pasture, and silage) are given in Table III.12.

Nuclide dependent transfer factors: Nuclide dependent soil to plant transfer factors are given in Table III.18. Nuclide dependent intake (fodder, silage, etc.) to animal product (meat and milk) transfer factors are given in Table III.14. Nuclide dependent water to aquatic food transfer factors are given in Table III.15.

Food and water storage times: Storage times for water and food stuffs are given in Table III.16.

Cover layer: data for the layer covering the waste are given in Table III.17.

Waste layer: data for the waste are given in Table III.18.

Water infiltration: in Table III.17, which gives the data for the cover layer, the run-off coefficient and evapotranspiration coefficient are defined such that the water infiltration rate is given by [28].

$$I = (1 - C_e)[P_r(1 - C_r) + I_{rr}] \quad (\text{III.1})$$

where:

C_e = evapotranspiration coefficient (0.5, dimensionless),

C_r = runoff coefficient (0.2, dimensionless),

P_r = precipitation rate (annual rainfall, 1.0 m/yr), and

I_{rr} = irrigation rate (0.2 m/yr).

Radon exhalation: the radon exhalation rate for soil/waste is known to depend on the moisture content of the soil/waste. As this dependence is complex, assume that the values given in Table III.17 (cover) and Table III.18 (uncovered waste) are annual average values.

Unsaturated and saturated zones: the data for the unsaturated zone and the saturated zone are given in table III.19 and Table III.20 respectively.

Partition coefficients: partition coefficients (K_d) are given in Table III.21. Several authors ([1], [28], [60]) have presented values for partition coefficients for specified radionuclides and a range of soil types. The principal feature of the data presented is the high variability, even for similar soil types. To enable results from different models to be directly compared, it is necessary to specify a single value for each radionuclide and each soil type. The values suggested are given in Table III.21.

Dose calculations: The aim is to estimate the annual doses to residents of the three houses shown in Figure III.2, assuming that each person spends 16 hours indoors and 8 hours outdoors (see Table III.10). Assume that a resident of House #1 works only in Field #1 (the waste pit area), that a resident of House #2 works only in Field #2, and that a resident of House #3 works only in Field #3.

III.3.3. Data tables and figures for hypothetical area source scenario

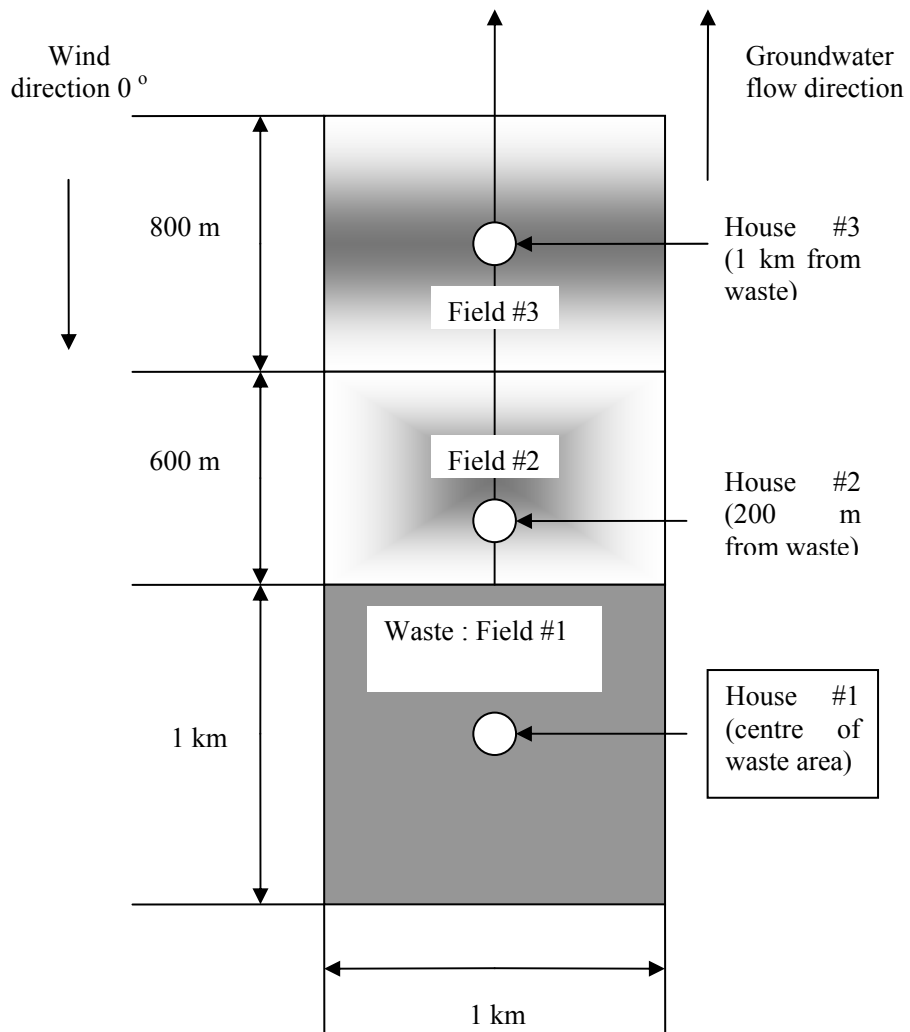

Fig. III.2. Plan of the site for the area source scenario.

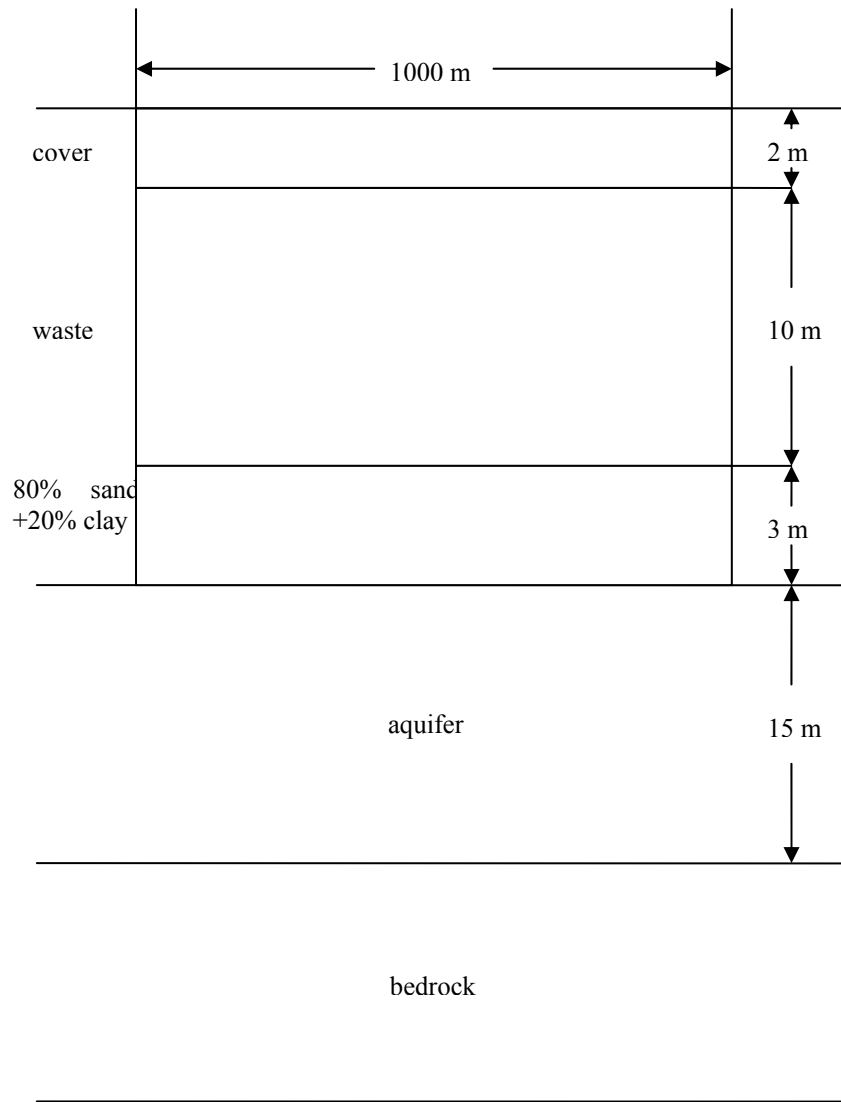

Fig. III.3. Vertical profile of the site for the area source scenario.

Table III.7. Annual wind rose data.

Sector	Wind Direction	Frequency (%)
1	345° - < 15°	4.6
2	15° - < 45°	5.4
3	45° - < 75°	7.6
4	75° - < 105°	5.4
5	105° - < 135°	3.8
6	135° - < 165°	7.4
7	165° - < 195°	14.1
8	195° - < 225°	20.3
9	225° - < 255°	13.3
10	255° - < 285°	7.5
11	285° - < 315°	6
12	315° - < 345°	4.1

Table III.8. Annual atmospheric stability and wind speed data.

Pasquill stability category	Frequency (%)	Mean Wind Speed (m s ⁻¹)
A	0.5	1
B	0.5	1.5
C	4	2.5
D	28	5
E	38	8
F	27	6
G	2	4

Table III.9. Dietary data (consumption rates) for humans.

drinking water	well	400	L a ⁻¹
fish		5	kg a ⁻¹
grains	+ grain products	80	kg a ⁻¹
fruits	+ juices	80	kg a ⁻¹
vegetables		70	kg a ⁻¹
meat	+ sausages	40	kg a ⁻¹
milk	+ milk products	90	kg a ⁻¹
root crops	without tubers	70	kg a ⁻¹
tubers		90	kg a ⁻¹

Table III.10. Occupancy data.

indoors – sleeping	8	h
indoors - light exercise	8	h
outdoors - light exercise	4	h
outdoors - heavy exercise	4	h

Table III.11. Dietary data (consumption rates) for beef cattle.

Water (surface)	60	L d ⁻¹
Pasture and silage	14	kg d ⁻¹
Grain	54	kg d ⁻¹
Soil from pasture and silage	0.1	kg d ⁻¹
Soil from grain	0.4	kg d ⁻¹

Table III.12. Plant and crop factors for human and livestock foods.

Crop factor	units	Leafy veg	Fruit, grain, non-leafy veg	Pasture, silage
Wet weight crop yield	kg m ⁻²	1.5	0.7	1.1
Duration of growing season	a	0.25	0.17	0.08
Foliage to food transfer coefficient		0.1	0.1	1
Weathering removal constant	a ⁻¹	20	20	20
Foliar interception factor (irrigation)		0.25	0.25	0.25
Foliar interception factor (dust)		0.25	0.25	0.25
Root depth	m	0.9	1.2	0.9

Table III.13. Nuclide dependent soil to plant transfer factors.

	Pb mBq kg⁻¹ (mBq kg⁻¹)⁻¹	Ra mBq kg⁻¹ (mBq kg⁻¹)⁻¹	Th mBq kg⁻¹ (mBq kg⁻¹)⁻¹	U mBq kg⁻¹ (mBq kg⁻¹)⁻¹
Fruit	0.01	0.04	0.001	0.0025
Grain	0.01	0.04	0.001	0.0025
Non-leafy veg	0.01	0.04	0.001	0.0025
Leafy veg	0.01	0.04	0.001	0.0025
Pasture, silage	0.01	0.04	0.001	0.0025
Livestock feed grain	0.01	0.04	0.001	0.0025

Table III.14. Nuclide dependent intake to animal product transfer factors.

	Pb mBq kg⁻¹ (mBq d⁻¹)⁻¹	Ra mBq kg⁻¹ (mBq d⁻¹)⁻¹	Th mBq kg⁻¹ (mBq d⁻¹)⁻¹	U mBq kg⁻¹ (mBq d⁻¹)⁻¹
Meat	0.0008	0.001	0.0001	0.00034
Milk	0.0003	0.001	0.000005	0.0006

Table III.15. Nuclide dependent water to aquatic food transfer factors.

	Pb mBq kg⁻¹ (mBq L⁻¹)⁻¹	Ra mBq kg⁻¹ (mBq L⁻¹)⁻¹	Th mBq kg⁻¹ (mBq L⁻¹)⁻¹	U mBq kg⁻¹ (mBq L⁻¹)⁻¹
Fish	300	50	100	10
Crustacean	100	250	500	60

Table III.16. Storage times for water and foodstuffs.

Consumable	Storage time	Units
Surface water	1	days
Well water	1	days
Fruits, grains, non-leafy vegetables	14	days
Leafy vegetables	1	days
Pasture, silage	1	days
Livestock feed grain	45	days
Meat	20	days
Milk	1	days
Fish	7	days
Crustacean, molluscs	7	days

Table III.17. Cover data.

Parameter	Value	Units
Depth	2	m
Porosity	0.4	
Effective porosity	0.2	
Density	1.5	g cm ⁻³
Rainfall	1	m a ⁻¹
Runoff coefficient ³	0.2	dimensionless
Evapotranspiration coefficient ⁴	0.5	dimensionless
Erosion rate	0.1	mm a ⁻¹
Exhalation rate ⁵	0.02 ⁶	Bq m ⁻² s ⁻¹

³ See text.⁴ See text.⁵ See text.

Table III.18. Waste data.

Parameter	Value	Units
Length	1000	m
Width	1000	m
Depth	10	m
²³⁸ U (in secular equilibrium with its progeny)	1	Bq g ⁻¹
Porosity	0.4	
Effective porosity	0.2	
Density	1.5	g cm ⁻³
Moisture content	0.3	8 months
	0.1	4 months
Erosion rate	0.1	mm a ⁻¹
Exhalation rate (uncovered) ⁷	1	Bq m ⁻² s ⁻¹

Table III.19. Unsaturated zone data.

Parameter	Value	Units
Thickness	3	m
Composition	sand	80 %
	clay	20 %
Porosity	0.4	
Effective porosity	0.2	
Hydraulic conductivity	10	m a ⁻¹

Table III.20. Saturated zone data.

Parameter	Value	Units
Thickness	10	m
Sand	1	
Porosity	0.4	
effective porosity	0.2	
Darcy velocity	0.1	m d ⁻¹

Table III.21. Partition coefficient KD of radionuclides in soils (L kg⁻¹) [1].

Nuclide	Sand	Loam	Clay	Organic
Ac	450	1500	7400	5400
Bi	120	400	670	1500
Pa	540	1800	2700	6600
Pb	270	16000	540	22000
Po	150	400	2700	6600
Pu	540	1200	4900	1800
Ra	490	36000	9000	2400
Th	3000	3300	5400	89000
U	33	12	1500	400

⁶ Depends on moisture content.⁷ See text.

III.4. Hypothetical area source + river scenario

III.4.1. Site Description

The site is an area source consisting of a layer of contaminated waste 1000 m long by 1000 m wide by 10 m thick, with a cover layer of soil 2 m thick. The waste is situated 300 m from a river (in the direction of the groundwater flow) and the river flows at right angles to the direction of groundwater flow. The plan of the site is shown in figure III.4. This figure also shows the reference direction for the wind rose, the direction of groundwater flow, and the locations of two houses.

Below the waste is a 3 m thick unsaturated layer consisting of a mixture of sand and clay. Below the unsaturated layer is a saturated layer of sand 10 m thick. The vertical layout of the waste is exactly the same as for the area source scenario and is shown in Figure III.3.

Many of the data specification tables for this scenario are the same as for the area source scenario, and are shown in the previous section. These include the annual wind rose data, the annual atmospheric stability data, dietary data (assume that the contaminated fraction for each type of food is 0.5), partition coefficients, unsaturated zone data, and saturated zone data.

In the run-off coefficient and evapotranspiration coefficient are defined such that the water infiltration rate is given by [28] as:

$$I = (1 - C_e)[P_r(1 - C_r) + I_{rr}] \quad (\text{III.2})$$

where:

C_e = evapotranspiration coefficient (0.5, dimensionless),
 C_r = runoff coefficient (0.2, dimensionless),
 P_r = precipitation rate (annual rainfall, 1.0 m/yr), and
 I_{rr} = irrigation rate (0.2 m/yr).

The radon exhalation rate for soil/waste is known to depend on the moisture content of the soil/waste. As this dependence is complex, assume that the values given in Table III.18 (cover) and Table III.21 (uncovered waste) are annual average values.

The aim is to estimate the annual doses to residents of the two houses shown in Figure III.4, assuming that each person spends 16 hours indoors and 8 hours outdoors (see Table III.10) working in the field surrounding the house occupied by that person. Each field is assumed to be 1 km by 1 km in area with the house at the North-east corner.

For soil, use the values of porosity and effective porosity given in Table III.19 (unsaturated zone data).

For each house, drinking water is supplied from a well situated at the location of the house. Irrigation water is drawn from the river.

The river data are shown in Table III.22.

III.5. Data tables and figures for hypothetical area source + river scenario

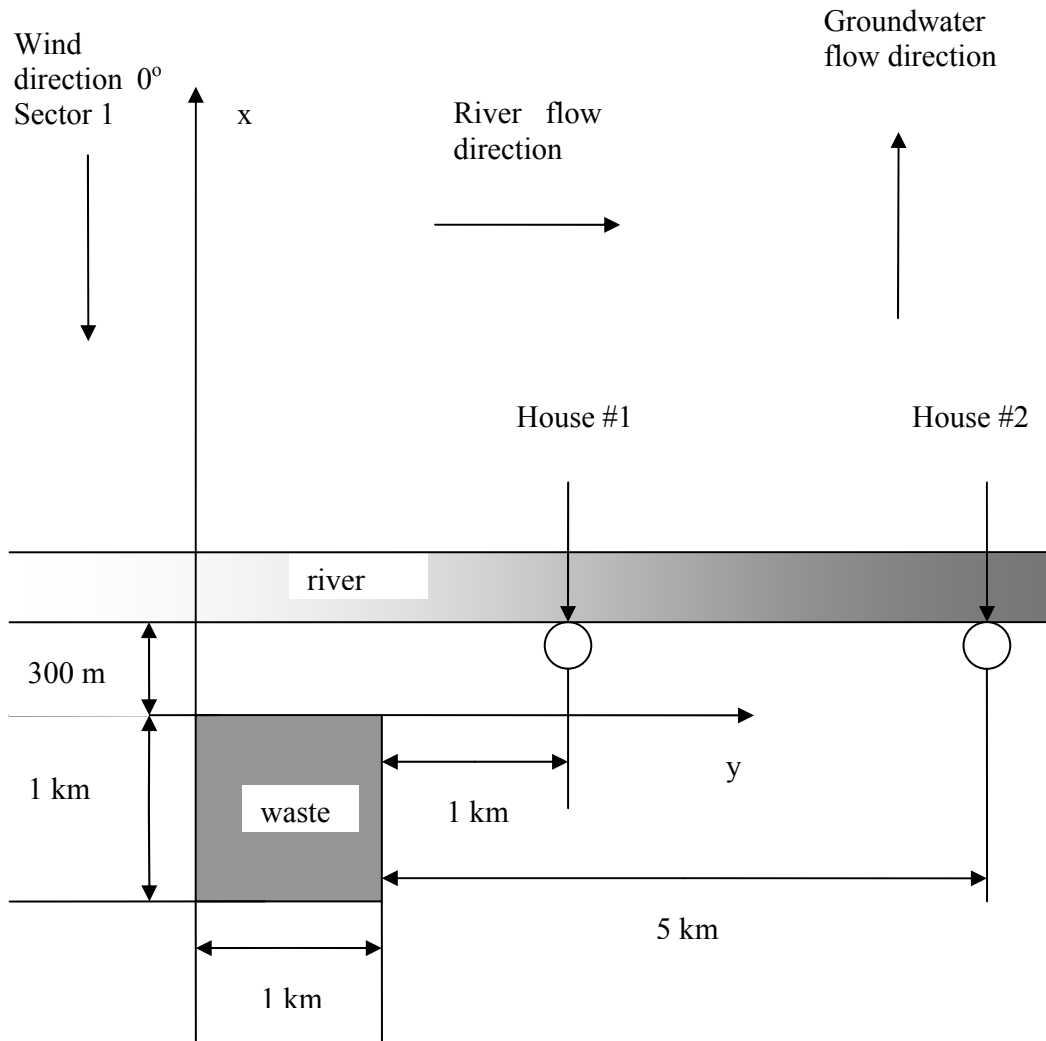

Fig. III.4. Plan of the site for the area source plus river scenario.

Table III.22. River data.

Parameter		Value	Units
distance from edge of waste		300	m
Flow rate		20	$\text{m}^3 \text{s}^{-1}$
Depth	water column	2	m
	top sediment	0.2	m
	thickness velocity	1	km a^{-1}
house #1	downstream distance	1000	m
	drinking water	well	
house #2	irrigation water	river	
	downstream distance	5000	m
	drinking water	well	
	irrigation water	river	

APPENDIX IV. TESTING OF HYPOTHETICAL POINT SOURCE SCENARIO

This testing was carried by two modellers using the COMPLY package, and by two modellers using the PC-CREAM package.

IV.1. COMPLY, CAP-88

IV.1.1. Introduction

The working group on “Modelling of naturally occurring radioactive materials (NORM) releases and of the remediation benefits for sites contaminated by extractive industries (U/Th mining and milling, oil and gas industry, phosphate industry, etc)” (i.e. the NORM working group) has developed a set of hypothetical scenarios for model validation and performing model calculations for comparing of models of different complexity. The first of the scenarios is the “Hypothetical Point Scenario” described below.

The purpose of this work is:

- to provide a means for comparing the predictions of different models obtained by participants of working group against each other; and
- for such comparison to present results obtained by easily available screening models.

IV.1.2. Point Scenario – Scenario Description

The scenario specifications are given in Appendix III.2. The site description is given in Appendix III.2.1, and the plan of the site is given in Figure III.1.

It is assumed that the contaminated fraction for each food type is 0.5.

It is also assumed that each person spends about 12 hours indoors each day.

The aim of the exercise is to estimate the annual doses to residents at distances of 300 m and 1500 m from the stack in every wind rose direction. It is assumed that residents live and work only in the close vicinity of their houses.

The COMPLY and CAP-88C models use wind-rose input data specified for 16 wind directions. The hypothetical point source scenario only specified 12 wind directions. Therefore the first step was to calculate suitable wind-rose data from the values specified in Table III.1. The results of these calculations are shown in Table IV.1.

Table IV.1. Annual data as given for the 12-direction wind rose and the corresponding 16-directions wind rose.

Sector	Wind Direction	Frequency for 12-direction wind rose (%)	Frequency for 16-direction wind rose (%)	Sector	Wind Direction
1	345° - < 15°	4.6	3.5	1	N
2	15° - < 45°	5.4	4.0	2	NNE
3	45° - < 75°	7.6	4.9	3	NE
			5.4	4	ENE
4	75° - < 105°	5.4	4.1	5	E
5	105° - < 135°	3.8	3.1	6	ESE
6	135° - < 165°	7.4	4.2	7	SE
			6.4	8	SSE
7	165° - < 195°	14.1	10.6	9	S
8	195° - < 225°	20.3	14.5	10	SSW
9	225° - < 255°	13.3	12.6	11	SW
			9.3	12	WSW
10	255° - < 285°	7.5	5.6	13	W
11	285° - < 315°	6	4.7	14	WNW
12	315° - < 345°	4.1	3.8	15	NW
			3.1	16	NNW

The stack height and discharge data are given in Table III.3.

IV.1.3. Default data for the COMPLY model

The COMPLY/CAP88 code uses the activity to dose conversion factors in Table IV.2. Consumption rates and occupancy factors are in default data files and have not been changed.

Table IV.2. Activity to dose conversion factors for ingestion and inhalation used by the COMPLY/CAP88 code.

Activity to Dose Conversion Factor	Ingestion (Sv/Bq)	Inhalation (Sv/Bq)
²¹⁰ Pb+D	1.5E-06	3.7E-06
²¹⁰ Po	5.1E-07	2.5E-06
²²⁶ Ra+D	3.6E-07	2.3E-06
²³⁰ Th	1.5E-07	8.8E-05
²³⁴ U	7.6E-08	3.6E-05
²³⁸ U+D	7.3E-08	3.2E-05

The code calculates radionuclide concentrations in various foods by coupling the output of the atmospheric transport models with the food chain models.

The dose estimated by this code at any given location is used for comparison with environmental standards [41] and is not intended to represent actual doses to real people.

Dose estimates are applicable only to chronic exposures. More information is available in references [23], [24] and [25].

IV.1.4. Results

The results of the calculations are shown in the next two figures.

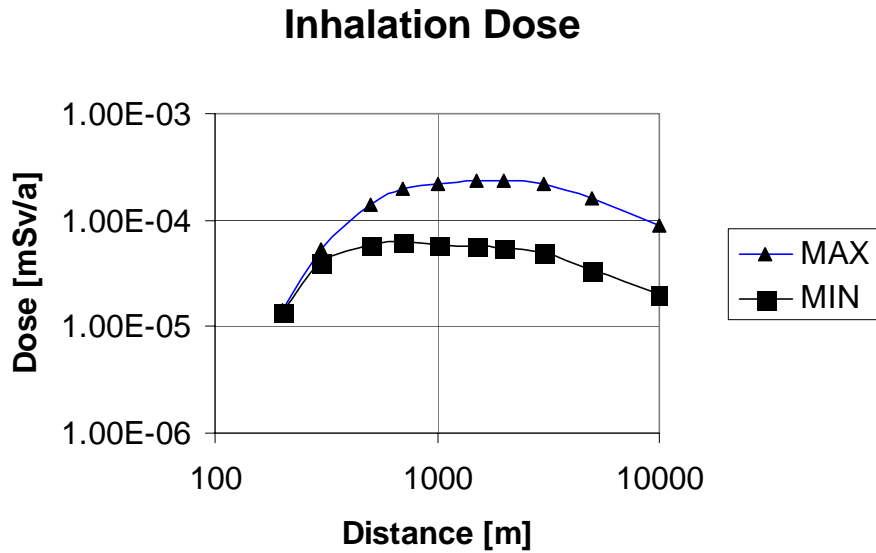

Fig. IV.1. Maximal and minimal total inhalation dose vs. distance from stack.

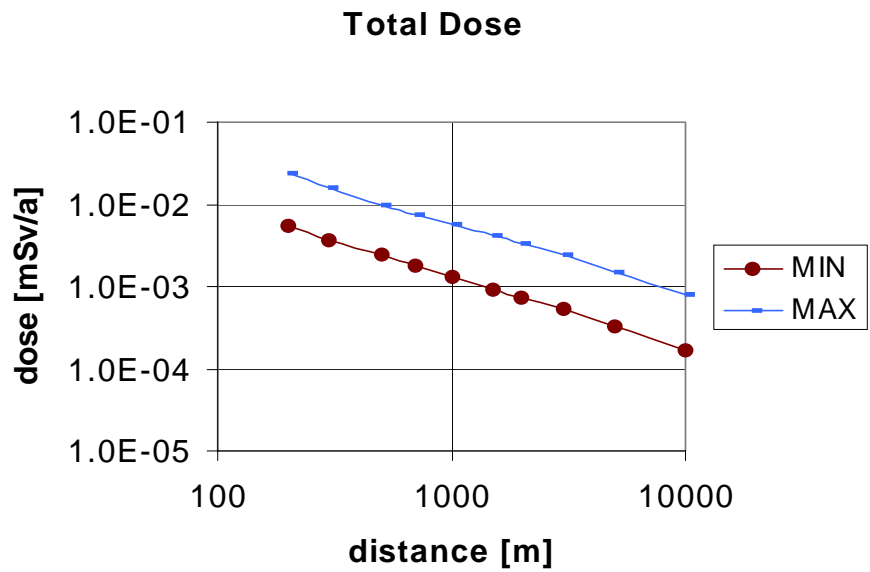

Fig. IV.2. Maximal and minimal total dose plotted vs. distance from stack.

Inhalation and total doses as a function of distance from the stack are plotted in Figure IV.1 and Figure IV.2. TableIV.3 shows the maximal doses for residents in house No. 1 and House No. 2 at distances of 300 m and 1500 m respectively from the stack.

Table IV.3. Maximal doses from airborne releases for 2 distances from the stack.

Computer Code:	CAP88-PC	COMPLY(Level 2)	COMPLY(Level 4)
Resident in House No.1			
Ingestion dose (%)	99	Not available	Not available
Inhalation dose (%)	< 1	Not available	Not available
Dose from Radon (%)	<0.1	<1	<1
Total Dose (mSv/a)	0.019	0.016	0.0087
Resident in House No.2			
Ingestion dose (%)	94	Not available	Not available
Inhalation dose (%)	5	Not available	Not available
Dose from Radon (%)	1	1	1
Total dose (mSv/a)	0.0047	0.016	0.0023

It should be carefully noted that doses obtained by COMPLY using Level 2 are the same for both distances. In this screening approach, the maximum value of radionuclide concentration in air for a given release height is used for all distances less than the distance corresponding to the maximal concentration.

Differences between numerical values of doses are attributed to the differences between the default values of model parameters used for each calculation, as expected.

IV.2. PC-CREAM

IV.2.1. Methodology used with PC-CREAM

The processes modelled in PC-CREAM that influence the transfer of radionuclides in the receiving terrestrial environment are:

- Deposition from the atmosphere;
- Migration of radionuclides in soil;
- Transfer to plants; and
- Transfer to animals.

In performing the Hypothetical Point Source (HPS) scenario, all of the supporting modules in PC-CREAM, with the exception of DORIS, were used. For the HPS scenario, to calculate the aerial dispersion factors, the PLUME program was used to generate the dispersion data libraries for ^{210}Po , ^{210}Pb and ^{222}Rn , using the meteorological data provided. Next, a library of concentrations of ^{210}Po and ^{210}Pb in foodstuffs was created using the FARMLAND module. In PC-CREAM, the migration of radionuclides in soil is represented by two distinct soil models: undisturbed soil, where the movement of the radionuclides is represented by a series of transfers between compartments of varying depth, and disturbed soil that is kept well mixed by frequent ploughing or cultivation [26]. For this assessment, the undisturbed soil model was selected. Food consumption rates were those provided in the HPS scenario description (Appendix III.2).

To calculate the gamma-dose rates resulting from the deposition of radionuclides, the GRANIS module was run to calculate a library of time integrated effective gamma doses resulting from the deposition of ^{210}Po and ^{210}Pb onto the ground surface. As with FARMLAND, GRANIS has two soil models available, undisturbed and ploughed. Again, the undisturbed soil model was used. The RESUS module was run to calculate a library of time

integrated resuspended activity concentrations in air of ^{210}Po and ^{210}Pb for the model's default integration times.

Finally, using the habit data and discharge data provided, and using the output library files created from the various modules within PC-CREAM, food concentrations were calculated using ASSESSOR, the dose assessment module of PC-CREAM. After all of these steps had been performed, ASSESSOR could then calculate the individual committed effective doses to the residents in the HPS scenario.

IV.2.2. PC-CREAM Results

Three modellers used PC-CREAM to test this scenario. All modellers obtained similar results.

For a uniform wind-rose, the predicted inhalation and total doses are shown in Figure IV.3. These calculations were made to improve familiarity with the operation of the program and to test that the radionuclides ^{210}Po and ^{210}Pb were being picked up by the ASSESSOR module. These radionuclides are not included in all the PC-CREAM radionuclide databases, and had to be added to test the scenario.

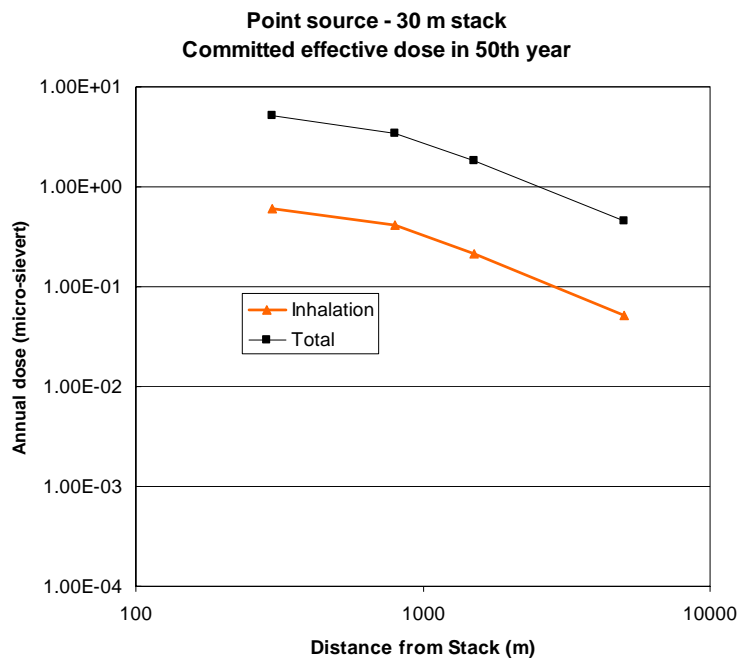

Fig. IV.3. Inhalation and total doses calculated for the hypothetical point-source scenario using PC-CREAM (radionuclides ^{210}Po , ^{210}Pb , ^{210}Bi).

The calculated inhalation and total doses for the hypothetical point-source scenario, for a discharge rate of 100 Bq s^{-1} for each radionuclide (^{210}Po , ^{210}Pb , ^{210}Bi , ^{222}Rn), are shown in Figure IV.4.

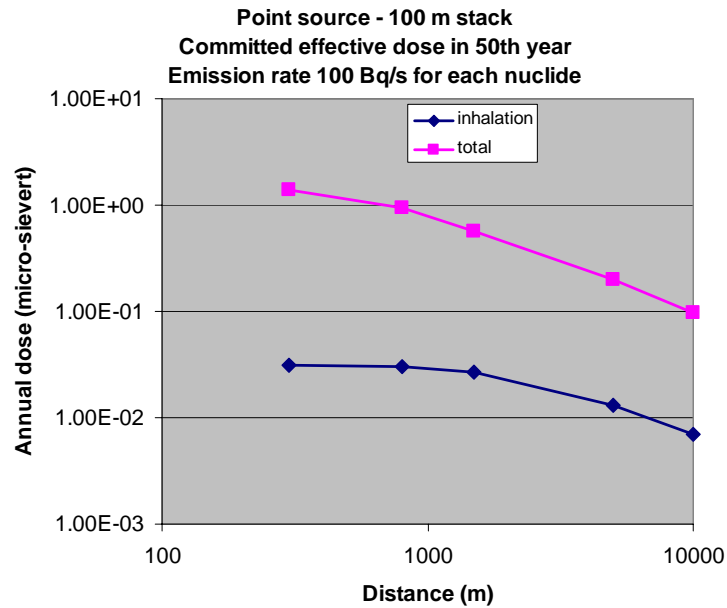

Fig. IV.4. Inhalation and total doses calculated for the hypothetical point-source scenario using PC-CREAM (radionuclides ^{210}Po , ^{210}Pb , ^{210}Bi , ^{222}Rn), for discharge rates of 100 Bq s^{-1} for each of ^{210}Po , ^{210}Pb and ^{222}Rn .

The calculated inhalation and total doses for the hypothetical point-source scenario, for the discharge rate given in the scenario specifications for each radionuclide (^{210}Po , ^{210}Pb , ^{210}Bi , ^{222}Rn), are shown in Figure IV.5.

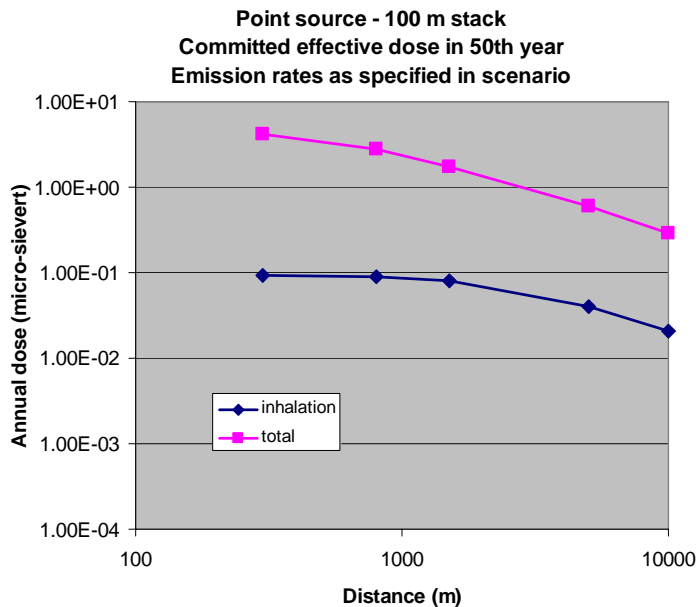

Fig. IV.5. Inhalation and total doses calculated for the hypothetical point-source scenario using PC-CREAM (radionuclides ^{210}Po , ^{210}Pb , ^{210}Bi , ^{222}Rn), for discharge rates of ^{210}Po , ^{210}Pb and ^{222}Rn as specified in the scenario.

These results are comparable with those calculated using COMPLY, but PC-CREAM predicts that both the inhalation and total doses will decrease with increasing distance whereas COMPLY predicts that the inhalation dose will increase with distance out to approximately 1000 m, then remain constant out to approximately 3000 m and then decrease with increasing distance.

Differences between the predictions of COMPLY and PC-CREAM are not unexpected. COMPLY is designed to check compliance with regulatory requirements and is deliberately conservative, whereas PC-CREAM is a much more detailed model that can be used for impact assessment purposes. In view of this, the higher doses predicted by COMPLY are acceptable.

IV.2.3. CROM results

CROM is based on the generic model described in the technical report series No.19 for the IAEA. The main considerations for running CROM for this scenario were:

- calculation for ^{210}Pb , ^{210}Bi , ^{210}Po with emission 100 Bq s^{-1} ;
- an assumed wet and dry deposition coefficient of 500 m d^{-1} ;
- the only atmospheric stability category considered was Pasquill-Gifford class D;
- an assumed mean wind velocity of 4 m s^{-1} ;
- the assumed fraction of time that the wind blows in the sector containing the receptor points was 0.46.

The results of the calculations are shown in the following tables and figures.

Table IV.4. Results of the dose calculations for different pathways as a function of the distance from the stack.

Pathways	Distance (m)					
	300	500	900	1500	5000	10000
	Doses (Sv a⁻¹)					
Immersion in Air	3.80E-15	5.35E-14	9.95E-14	7.11E-14	1.18E-14	3.48E-15
Deposition in Soil	4.15E-09	5.84E-08	1.09E-07	5.97E-08	1.28E-08	2.92E-09
Food Ingestion	3.40E-07	6.27E-06	8.91E-06	6.27E-06	1.05E-06	3.07E-07
Inhalation	4.75E-09	6.69E-08	1.25E-07	8.89E-08	1.47E-08	4.36E-09
Total	3.49E-07	6.40E-06	9.14E-06	6.42E-06	1.08E-06	3.14E-07

Pathways	Distance (m)					
	300	500	900	1500	5000	10000
	Doses (Sv a⁻¹)					
Immersion in Air	3.80E-15	5.35E-14	9.95E-14	7.11E-14	1.18E-14	3.48E-15
Deposition in Soil	4.15E-09	5.84E-08	1.09E-07	5.97E-08	1.28E-08	2.92E-09
Food Ingestion	3.40E-07	6.27E-06	8.91E-06	6.27E-06	1.05E-06	3.07E-07
Inhalation	4.75E-09	6.69E-08	1.25E-07	8.89E-08	1.47E-08	4.36E-09
Total	3.49E-07	6.40E-06	9.14E-06	6.42E-06	1.08E-06	3.14E-07

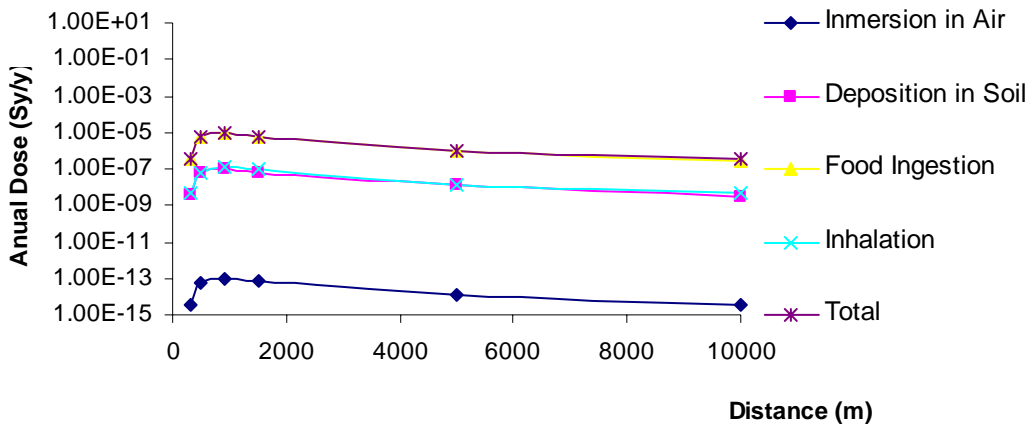

Fig. IV.6. Doses for the hypothetical point source, using CROM, for the radionuclides ^{210}Po , ^{210}Pb , ^{210}Bi , for different pathways, as a function of distance from the stack.

Table IV.5. Results for the receptor points (House 1 and 2) for the Point source hypothetical scenario.

Pathways	House 1		House 2	
	Dose Sv/y	%	Dose Sv/y	%
Immersion in Air	3.80E-15	<1	7.11E-14	<1
Deposition in Soil	4.15E-09	1.48	5.97E-08	1.16
Food Ingestion	2.72E-07	96.83	5.02E-06	97.12
Inhalation	4.75E-09	1.69	8.89E-08	1.72
Total	2.81E-07		5.17E-06	

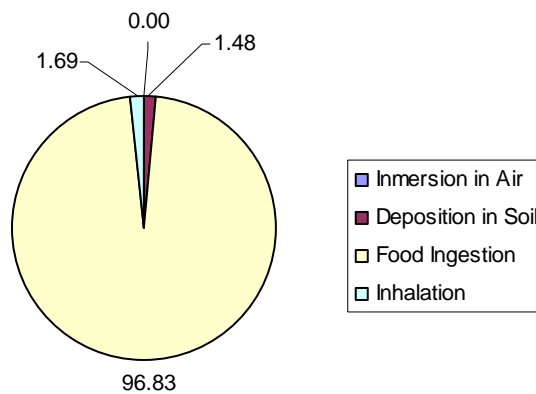

Fig. IV.7. Calculated doses for different pathways at receptor point House 2.

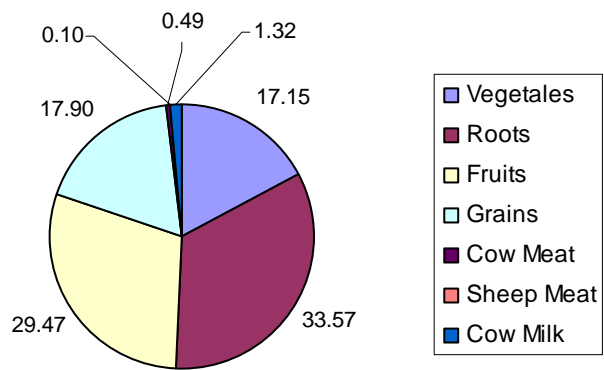

Fig. IV.8. Calculated doses for different ingestion pathways at receptor point House 2.

APPENDIX V. TESTING OF THE HYPOTHETICAL AREA SOURCE SCENARIO

V.1. DOSDIM and HYDRUS

A brief description of the DOSDIM + HYDRUS package is given in Appendix II.1.7. One modeller used DOSDIM & HYDRUS to test this scenario. A second modeller repeated and revised the calculations. The revised results are presented below.

V.1.1. Methodology used with DOSDIM and HYDRUS

The one-dimensional version HYDRUS 1D was used for the modelling of the transport of the radionuclides through the VADOSE zone (unsaturated) under the waste, into the aquifer (saturated zone). The concentrations of the radionuclides in the aquifer at the location of the exposure point (a well at the house), were then calculated with HYDRUS 2D using the output values from the 1D version as input.

The configuration of the site is shown in Figure V.1.

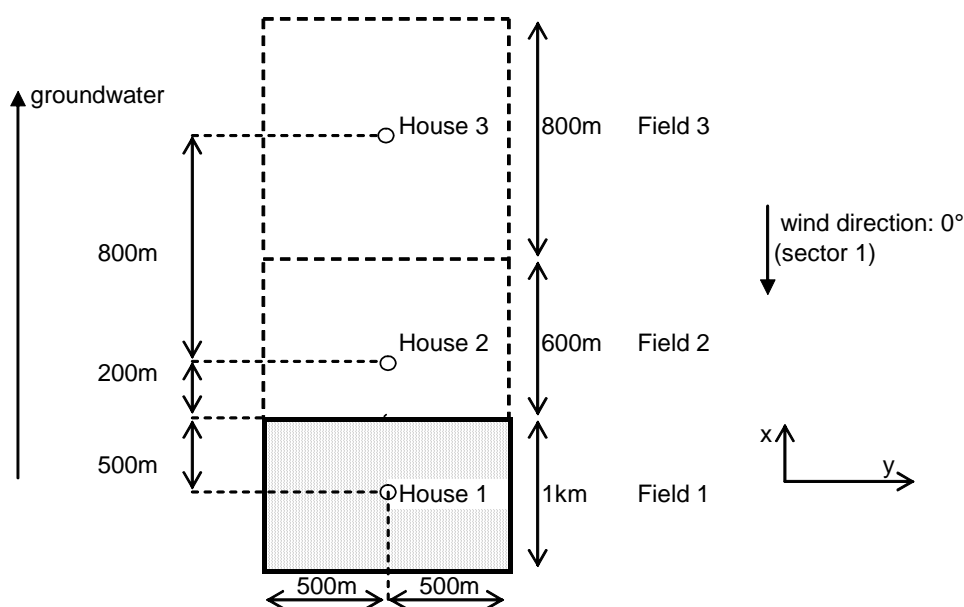

Fig. V.1. Configuration of area source and exposure points – the shaded part is the area source (location of waste), the exposure points are houses 1 and 2 (house 3 was not considered) and fields 1 and 2 (representative points in the centre of each field).

V.1.2. Exposure pathways to be considered

The exposure pathways considered are:

- Inhalation of radon exhaled from the waste;
- External irradiation from the waste;
- Inhalation of resuspended dust;
- Ingestion of water from a contaminated well.

V.1.2.1. Modelling of the ^{222}Rn concentrations in the air due to exhalation from the waste

The individual dose to the exposure group due to inhalation of radon decay products, has been assessed outdoors (on the field) and indoors (in the houses). Distinction has further been made between the exposure above the waste (see Figure V.2: field 1 and house 1) and at a distance of 700m and 1500m from the centre of the waste (respectively field 2 and field 3, and house 2 and house 3), and between covered and uncovered waste. For long time ranges (> 100a) the thickness of the uncontaminated cover layer is considered to diminish exponentially with time due to erosion; the effect of this is somewhat reduced due to downward migration of the contamination.

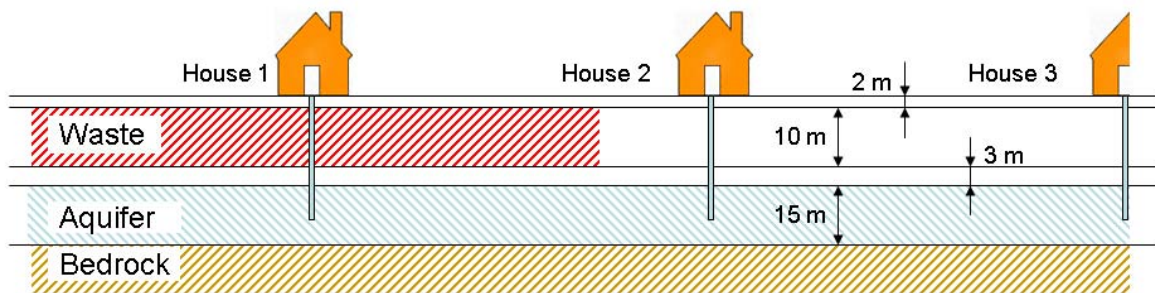

Fig. V.2. Cross-section through area source and exposure points.

The modelling of the ^{222}Rn concentrations in the air due to exhalation from the waste is performed with the extra module of the DOSDIM model. The extended area source, formed by the waste, is herein divided into elementary square sources of 100m x 100m (x 10m deep). The total impact from the waste is then calculated as the sum of impacts from all these elementary sources, which are considered to be located at their centres. The distances and directions to the exposure points are easily calculated, locating the latter at the centre of the houses and fields in the zones 1 (at the waste area), 2 and 3 (outside the waste area).

For modelling the atmospheric dispersion of the exhaled radon, and its daughter radio-nuclides, a 2-dimensional Gaussian model is used. The well-known Pasquill-Gifford dispersion parameters (i.e. the standard deviations of the cross-wind and vertical wind distributions) are expressed as a function of the Pasquill weather type and of the distance from the elementary source (centre) to the exposure point.

For each elementary source – exposure point configuration, the frequency of occurrence of the wind blowing in the sector, encompassing the exposure point considered, and of the wind blowing in the adjacent sectors, is calculated from a table of meteorological observations. For each elementary source – exposure point configuration, the frequency of occurrence of the wind blowing in the sector, encompassing the exposure point considered, and of the wind blowing in the adjacent sectors, is calculated from a table of meteorological observations. Then, for the same configurations, and for each stability class, the time-averaged dilution factor is calculated, taking into account the distribution of the wind direction.

The contributions for the wind blowing in the sector containing the receptor, and the "fringes" for the wind blowing in the adjacent sectors, are summed up, yielding the average dilution factor for the exposure point considered (for each elementary source and each stability class). Multiplying these average dilution factors with the frequency of occurrence of each stability

class and of the wind direction considered and summing up the weighted dilution factors results in the total average dilution factor for the exposure point, from the whole waste pit (= all the elementary sources).

Multiplication with the exhalation flux of radon yields the average radon concentration in the air at the exposure point, from which the individual dose due to inhalation of exhaled radon is calculated. The radon exhalation rate from the covered waste is lower than that of the uncovered waste. Consequently the individual dose from covered waste is lower. Due to the erosion, the thickness of the cover in the former case will decrease exponentially with time down to approximately 1m at 10 000 years.

V.1.2.2. External irradiation from the waste

This exposure pathway is only important on the fields and in the house above the waste. Both cases of covered (2m thick) and uncovered waste are considered. With respect to the location of the labourers on the field, working on the edge of the waste area would result in an external dose rate equal to half the value at the centre of the waste area, and in an inhalation dose rate from resuspension, varying between 0 and a certain maximum value (depending on the prevalent wind directions). Therefore the central point of the fields has been considered as the representative points, where the dose rates were assessed.

These two exposure pathways are easily modelled with DOSDIM, as described in the VAMP and BIOMASS reports mentioned above.

Only for the labourers working and living above the waste, the doses are relevant. A higher individual dose rate will be received above the uncovered waste than above the covered waste. The inhalation dose will be zero, and the external dose rate will be lower than for the uncovered waste, as long as the thickness of the covering layer has not been reduced to zero.

These two latter exposure pathways (inhalation of radon and external irradiation) are easily modelled with DOSDIM, as described in the VAMP and BIOMASS reports mentioned above. Only for the labourers working and living on the waste area, the doses will be relevant. A higher individual dose rate will be received on the uncovered waste than on the covered waste.

V.1.2.3. Inhalation of resuspended dust

This pathway is only relevant for uncovered waste. In the DOSDIM model the radionuclide concentrations in the resuspended dust are considered to be in equilibrium with the concentrations in the top soil, apart from an enhancement factor of 5 [61] because of the finer (more inhalable fraction) size of the particles in the air with respect to those in the top soil.

Inhalation of resuspended daughter radionuclides of ^{222}Rn , exhaled from the waste could also be taken into consideration; however, its radiological impact is estimated to be unimportant.

Intuitively it is expected that, for the covered waste, the inhalation dose will be zero, and the external dose rate will be lower than that for the uncovered waste, as long as the thickness of the covering layer has not been reduced to zero.

V.1.2.4. Ingestion of water from a contaminated well

The downward transport of the radionuclides of the ^{238}U decay chain through the unsaturated soil under the waste and the concentration of the radionuclides which leached into the aquifer at the location of the waste have been modelled with the HYDRUS 1D software programme. The dilution after the radionuclides entered into the aquifer, the advection of the contaminants with the groundwater flux from under the waste area in the direction of the houses and the concentrations of the radionuclides in a well located near each house were calculated using HYDRUS 2D. During the entire transport, the decay and ingrowth of the short-lived daughter radionuclides have been taken into account. The aquifer was presumed to be 15m thick and located on top of bedrock (see Figure V.2). The hydrological parameters, which were not given in the original scenario description and which were used as input in the HYDRUS models are illustrated in Table V.1.

Table V.1. Comparison of the hydrological input parameters used in the Hydrus 1D and 2D models.

Soil compartment			Unsaturated zone ^a	Saturated zone ^b
Model used			HYDRUS1D	HYDRUS2D
Symbol	Name	Units	Value	
Q_r	Residual soil water content	-	0.07	0.045
Q_s	Saturated soil water content	-	0.41	0.43
A	Parameter in the soil water retention function	d^{-1}	2.39	14.5
N	Parameter in the soil water retention function	-	1.56	2.68
K_s	Saturated hydraulic conductivity	m d^{-1}	0.63	7.128
v_{inf}	Vertical water flux	m d^{-1}	0.00137	0.00137
v_d	Darcy velocity	m d^{-1}	-	0.1
P	Bulk density	kg m^{-3}	1500	1500
D_L	Longitudinal dispersivity	m	0.1	2
D_T	Transverse dispersivity	m	-	0.2
K_d	Dispersion coefficient			
	^{238}U	$\text{m}^3 \text{kg}^{-1}$	0.3264	0.033
	^{234}U	$\text{m}^3 \text{kg}^{-1}$	0.3264	0.033
	^{230}Th	$\text{m}^3 \text{kg}^{-1}$	3.48	3
	^{226}Ra	$\text{m}^3 \text{kg}^{-1}$	2.192	0.49
	^{210}Pb	$\text{m}^3 \text{kg}^{-1}$	0.324	0.27

^a soil composition: 80% sand and 20% clay.

^b soil composition: 100% sand.

For the calculation of the radionuclide concentrations in drinking water, it was assumed that the pump extracts water from the central part of the aquifer (central 10 m). Radionuclide concentrations in the upper and lower 5 m of the aquifer were not taken into account. After calculation of the concentrations of radionuclides in the well, the DOSDIM model is used to calculate the radionuclide concentrations in the food products. Contamination of food products may be caused by growing crops and pasture on contaminated land or by indirect contamination due to irrigation with contaminated water. If the agricultural land is irrigated with contaminated well water, all food products in both zones might be contaminated due to irrigation. Direct contact with the radioactive waste is only possible on field 1 and this only in the uncovered waste scenario.

V.1.3. Modelling of the ^{222}Rn concentrations in the air due to exhalation from the waste

One of the possible exposure pathways for which calculations were performed is the exhalation of ^{222}Rn out of the waste repository. The dispersion of the radon was calculated by subdividing the area of the repository (1 km x 1 km) into cells of 100m x 100m. This produces a grid which contains 100 different cells (see Figure V.3).

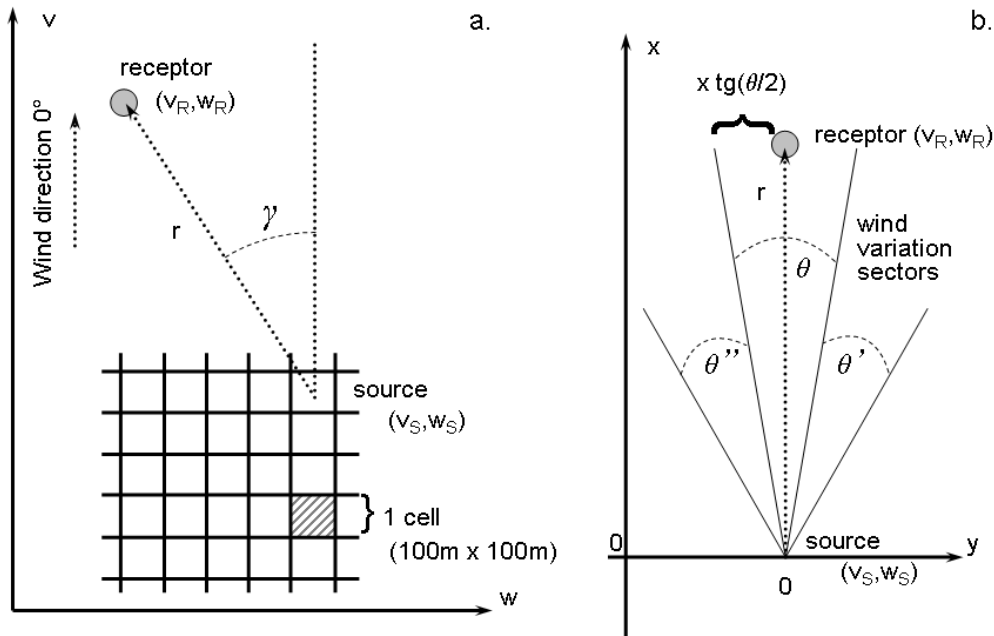

Fig. V.3. Schematic representations of the model formulations ($\text{tg}(\theta/2) = \tan(\theta/2)$).

From each of these cells, the distance r between the centre of this cell and a receptor point (house or field) was calculated, together with the angle of this line (γ) with a reference direction (wind direction 0°). This angle is used to determine in which sector, in relation to the wind direction, the receptor is located. For each of the cells the probability the wind blows over this cell in the direction of the receptor was calculated (P_θ). For each of the grids the dispersion parameter (σ_y and σ_z) between the centres of the cells and the house/field is calculated for different stability classes. Dispersion parameters are calculated using the following equations:

$$\begin{aligned} \sigma_y &= ax^b \\ \sigma_z &= cx^d + e' \end{aligned} \tag{V.1}$$

where x represents the distance between the source and the receptor (in meters), and the parameters a to e are empirically derived values, which depend on the different stability classes (see Table V.2).

Table V.2. Parameters used to calculate the stability class (given in the first column).

	100m < x < 400m			400m < x < 1000m			1000m < x < 10 000m				
	A	b	C	d	e	c	d	e	c	d	e
A	0.5269	0.8649	0.0060	1.5548	6.2686	0.0001	2.2217	16.3731	0.0002	2.0940	-9.6000
B	0.3710	0.8664	0.0371	1.1530	3.1914	0.0371	1.1530	3.1914	0.0540	1.0997	2.5397
C	0.2092	0.8971	0.0992	0.9289	0.2444	0.0992	0.9289	0.2444	0.0991	0.9255	1.7383
D	0.1277	0.9050	0.2066	0.7338	-1.3659	0.2066	0.7338	-1.3659	0.9248	0.5474	-9.0641
E	0.0975	0.9019	0.1975	0.6865	-1.1644	0.1975	0.6865	-1.1640	2.3441	0.4026	-16.3186
F	0.0653	0.9023	0.0984	0.7210	-0.3231	0.0984	0.7210	-0.3231	6.5286	0.2593	-25.1583

The average dilution is calculated using a Gaussian dispersion equation

$$DF'_{average} = \frac{P_{\theta}}{2 \cdot \pi \cdot u \cdot \sigma_z \cdot \sigma_y} \cdot \exp\left(-\frac{y^2}{2 \cdot \sigma_y^2}\right), \quad (V.2)$$

where:

P_{θ} = the probability the wind blows in the direction of the house/field (%);

y = the distance perpendicular to the wind direction (m);

u = the wind speed ($m s^{-1}$);

σ_z and σ_y = the dispersion parameter for the z- and y- directions.

When averaging over time, the mean wind directions are variable. Fluctuations around the average wind direction are taken into account by modifying the previous equation to:

$$DF_{average} = \frac{P_{\theta}}{2 \cdot \pi \cdot u \cdot \sigma_z \cdot \sigma_y} \cdot \frac{1}{2x \cdot tg(\theta/2)} \cdot \int_{-x \cdot tg(\theta/2)}^{x \cdot tg(\theta/2)} \exp\left(-\frac{y^2}{2 \cdot \sigma_y^2}\right) \cdot dy. \quad (V.3)$$

where θ represents the angle over which the wind variations are considered (Figure V.3).

By applying the error function and simplifying the equation by replacing $x \cdot tg(\theta/2)$ by $\pi \cdot r/n$, where n is the number of wind direction categories (see Table V.2), the formula can be rearranged to give:

$$DF_{average} = \frac{P_{\theta} \cdot n}{\sqrt{2\pi} \cdot \pi \cdot u \cdot \sigma_z \cdot r} \cdot erf\left(\frac{\pi \cdot r}{n \cdot \sigma_y \cdot \sqrt{2}}\right), \quad (V.4)$$

where r is the distance between centre of the grid and the house/field (m), and

$$erf(z) = \frac{2}{\sqrt{\pi}} \int_0^z e^{-t^2} dt \text{ with } z = \left(\frac{\pi \cdot r}{n \cdot \sigma_y \cdot \sqrt{2}}\right) \text{ and } t = \left(\frac{y}{\sqrt{2} \cdot \sigma_y}\right). \quad (V.5)$$

The concentration of radon in the air at the receptor is not only influenced by the wind coming from the sector, in which the receptor is located (θ), but might also be influenced, by the wind from the adjacent sectors (θ' and θ''). This phenomenon is called the fringe effects. Taking into account the fact that $erf(\infty) = 1$, the following approximation can be made for calculating these fringe effects:

$$DF_{fringe} = \frac{\left(\frac{P'_\theta + P''_\theta}{2}\right) \cdot n}{\sqrt{2\pi} \cdot \pi \cdot u \cdot \sigma_z \cdot r} \cdot \left[1 - erf\left(\frac{\pi \cdot r}{n \cdot \sigma_y \cdot \sqrt{2}}\right)\right], \quad (V.6)$$

where:

P'_θ = the probability that the wind blows $360^\circ/n$ out of the direction of the house/field (%),
and

P''_θ = the probability that the wind blows $-360^\circ/n$ out of the direction of the house/field (%).

For an elementary source the total dilution factor for a specific stability class is the sum of the average dilution factor ($DF_{average}$) and the dilution factor due to fringe effects (DF_{fringe}). The total annual dilution factors for each elementary source are calculated by multiplying the stability class specific dilution factors for each elementary source with the probability that a certain stability class occurs (Table III.8). The individual values are subsequently summed.

Two different scenarios were considered. For the covered waste scenario an exhalation rate of $0.02 \text{ Bq m}^{-2} \text{ s}^{-1}$ was used, while a value of $1 \text{ Bq m}^{-2} \text{ s}^{-1}$ was used for the uncovered waste scenario. The concentration in the air was calculated by multiplying the exhalation rate with the total dilution factor calculated for different locations.

The doses received due to residence in the house for both situations, covered and uncovered waste, is calculated on the basis of the exhalation of radon from the waste, followed by atmospheric dispersion, such as would be done for the open air (fields 1 and 2). However, for the house on the waste (house 1) another source of radon contamination has to be considered, namely the exhalation of radon from the waste directly into the house. This contribution is generally more important than the contribution from radon coming from the outside air.

For the calculation of the radon concentration in house 1 the method is different for both situations. In the case of the uncovered waste, the house is built on the same ground for which the exhalation and atmospheric dispersion has been calculated. In this case the radon concentration inside house 1 is higher than outside for two reasons, namely the smaller renewal rate of the air and the under-pressure in the house. Due to the first reason, the resulting radon concentration would amount to 4.8 Bq m^{-3} (equivalent to $14,400 \text{ Bq h}^{-1}$ for a ventilation flow rate of $300 \text{ m}^3 \text{ h}^{-1}$), which is 20 times higher than outside (0.24 Bq m^{-3}). The influence from the under-pressure is more difficult to quantify. However in field investigations (for example, at the storage plant at Olen) a global factor of 30 has been observed.

In the case of the covered waste, it is assumed that the house is built on a 30 cm thick layer of concrete. As before, the ratio of the radon concentration inside the house to that outside is assumed to be 30. The uncovered waste is considered to be so from the beginning since the gradual uncovering of the waste, due to erosion, lasts too long. ($> 20000\text{y}$) Over the period considered (1-1000 y), no radioactive decay is considered, because of the presence of the long-lived mother radionuclides of ^{226}Ra .

Radon inhalation for the critical group is calculated by multiplying the concentration of radon in the air (inside or outside) with the residence time at the location and the dose conversion factor for ^{222}Rn , given by:

$$H_{inh,Rn,out} = C_{a,Rn,out} \cdot T_{out} \cdot DF_{inh,Rn}, \quad (V.7)$$

and

$$H_{inh,Rn,in} = C_{a,Rn,in} \cdot T_{in} \cdot DF_{inh,Rn}. \quad (V.8)$$

For covered waste this dose is multiplied by a correction factor which accounts for the increase in radon exhalation due to the erosion of the shielding cover and the leaching of the waste. The correction factor is given by:

$$Corr_{Rn_exh}(t) = \exp \left[\sqrt{\frac{\lambda_{Rn}}{D_{Rn}}} \cdot (d_c(t_0) - d_c(t)) \right], \quad (V.9)$$

where:

λ_{Rn} = decay rate of ^{222}Rn (s^{-1});

D_{Rn} = exhalation rate of ^{222}Rn out of the waste ($\text{m}^2 \text{s}^{-1}$), and

$d_c(t)$ = thickness (m) of the cover layer at time t (a).

The thickness of the cover layer is given by

$$d_c(t) = d_c(t_0) - t \cdot rer + v_{Ra-226} \cdot t \quad (V.10)$$

where:

rer = relative erosion rate (m a^{-1})

v_{Ra-226} = leaching rate of ^{226}Ra out of waste, defined as:

$$v_{Ra-226} = \frac{v_w}{R_d} = \frac{v_w}{1 + \frac{\rho \cdot K_{d_Ra-226}}{\theta}} \quad (V.11)$$

where:

v_w = infiltration rate of water (m a^{-1});

ρ = soil bulk density (kg m^{-3});

K_{d_Ra-226} = distribution coefficient (m kg^{-1}), and

θ = soil moisture content (-).

V.1.4. External irradiation from the waste and inhalation of resuspended dust

The concentration in the air is calculated by multiplying the dust load factor with the concentration in the soil. Because of the finer (more inhalable fraction) size of the particles in the air with respect to those in the top soil, an enhancement factor of 5 is used [61]. The equations for the calculation of the dose are similar to those used for the effects of air radon concentrations, namely:

$$H_{inh,r,out} = B_{a,out} \cdot T_{out} \cdot \sum_r [C_{a,r,out} \cdot DF_{inh,r}] \quad (V.12)$$

$$H_{inh,r,in} = B_{a,in} \cdot T_{in} \cdot \sum_r [C_{a,r,in} \cdot DF_{inh_a,r}] \quad (V.13)$$

where:

$H_{inh,r,x}$ = individual effective annual dose for adults for inhalation of air (Sv a^{-1});
 $x = in$ for indoor exposure, $x = out$ for outdoor exposure;
 $B_{a,x}$ = inhalation rates for adults ($\text{m}^3 \text{h}^{-1}$);
 T_x = annual exposure time (h a^{-1}) for adults, and
 $DF_{inh,r}$ = effective dose factor for inhalation of radionuclide r for adults (Sv Bq^{-1}).

V.1.5. Calculation of water concentration in the aquifer

The radionuclide flow through the different soil layer is calculated using HYDRUS1D and 2D. HYDRUS is a Microsoft Windows based modelling environment for analysis of water flow and solute transport in variably saturated porous media. The software package includes computational finite element models for simulating the one- and two-dimensional movement of water, heat, and multiple solutes in variably saturated media. The model includes a parameter optimization algorithm for inverse estimation of a variety of soil hydraulic and/or solute transport parameters. The model is supported by an interactive graphics-based interface for data pre-processing, generation of structured and unstructured finite element meshes, and graphic presentation of the results. The program numerically solves the Richards' equation for saturated-unsaturated water flow:

$$\frac{\partial \theta}{\partial t} = \frac{\partial}{\partial z} \left[D_w(\theta) \left(\frac{\partial(\theta)}{\partial z} + K(\theta) \right) \right], \quad (\text{V.14})$$

and Fickian-based advection dispersion equations for heat and solute transport:

$$R \frac{\partial C_{liq}}{\partial t} = D \frac{\partial^2 C_{liq}}{\partial z^2} - v \frac{\partial C_{liq}}{\partial z} - \mu R C_{liq} - S_i \quad (\text{V.15})$$

The flow equation incorporates a sink term to account for water uptake by plant roots. The transport equation considers conduction as well as convection with flowing water. The solute transport equations consider advection-dispersive transport in the liquid phase, and diffusion in the gaseous phase. The transport equations also include provisions for nonlinear and/or non-equilibrium reactions between the solid and liquid phases, linear equilibrium reactions between the liquid and gaseous phases, zero order production, and two first-order degradation reactions (one which is independent of other solutes, and one which provides the coupling between solutes involved in sequential first-order decay reactions). The program may be used to analyze water and solute movement in unsaturated, partially saturated, or fully saturated porous media. More information on these models can be found at <http://www.pc-progress.cz/> or references [62] and [63].

V.1.6. Calculation of dose impact due to water and food ingestion

Drinking water extracted from a well is assumed not to undergo any treatment which can affect the radionuclide concentration in the drinking water. Therefore it can be assumed that the radionuclide concentration in the water in the receptor and the well compartments is the same, i.e.:

$$C_{wd,r} = C_{ww,r} \quad (\text{V.16})$$

where:

$C_{wd,r}$ = concentration of radionuclide r in drinking water (Bq m^{-3}); and
 $C_{ww,r}$ = concentration of radionuclide r in well water (Bq m^{-3})

Agricultural soil is assumed to be contaminated through irrigation with contaminated water extracted from the well. The concentrations of radionuclides in the soil (root zone soil) are determined from the input, characterised by the irrigation rate and irrigation period, and the losses, due to leaching out of the root zone soil and radioactive decay. According to reference [64] this leaching rate constant (λ_e) can be calculated by:

$$\lambda_e = \frac{Inf}{d_{s,v}(\varepsilon_s + \rho_s \cdot Kd_{s,r})}, \quad (\text{V.17})$$

where:

Inf = net infiltration rate of the water (m y^{-1});
 $d_{s,v}$ = thickness of the root zone soil for crop v (m);
 ε_s = volumetric water content of the root zone soil (-);
 ρ_s = bulk density of root zone soil (kg m^{-3}); and
 $Kd_{s,r}$ = distribution coefficient of radionuclide r in the root zone soil ($\text{m}^3 \text{kg}^{-1}$).

The annual averages of the radionuclide concentrations in the root zone soil are calculated for each radionuclide by taking the average of the radionuclide concentration at the beginning and the end of the irrigation period. This average is given by

$$C_{s,r} = C_{w,r} \cdot \frac{1}{2} \cdot \frac{I_{r,v}}{T_{ir,v}} \cdot \frac{1}{P_s \cdot \lambda_{e,r}} \left[\frac{\exp(-\lambda_{e,r} \cdot (1 - T_{ir,v})) - \exp(-\lambda_{e,r} \cdot T_{ir,v})}{(1 - \exp(-\lambda_{e,r}))} + 1 \right] \quad (\text{V.18})$$

in which:

$C_{s,r}$ = concentration of radionuclide r in root zone soil (Bq kg^{-1});
 λ_r = radioactive decay constant (y^{-1});
 $\lambda_{e,r}$ = effective decay constant (y^{-1}) = $\lambda_e + \lambda_r$;
 $T_{ir,v}$ = annual irrigation duration for food crop v (a a^{-1})
 $I_{r,v}$ = annual irrigation (m a^{-1})
 P_s = surface density of the root zone soil (kg m^{-1}) = $\rho_s \cdot d_s$

Food crops and pasture are considered to be contaminated through irrigation. Contamination is brought about through direct deposition on the external parts of the plants and through root uptake from the root zone soil. Interception is taken into account together with loss of radionuclides due to weathering during the irrigation period and between the end of the irrigation period and the harvest. The concentration of radionuclide r in crop v due to direct deposition (Bq kg^{-1}) is given by:

$$C_{v,l,r} = C_{w,r} \times I_r \times \frac{t_e}{T_{ir}} \times \frac{R}{Y} \times \frac{1 - \exp(-\lambda_w \times t_e)}{\lambda_{we}} \times \exp(-\lambda_w \times t_h) \quad (\text{V.19})$$

where:

$C_{v,1,r}$ is given as fresh weight (fw) for food crops, and dry weight (dw) for feed crops and pasture;

R = interception factor (-);

Y = herbage density of the plant (kg fw m⁻² for food crops; kg dw m⁻² for feed crops, pasture);

t_e = time during which the plant is externally exposed to irrigation (a a⁻¹);

λ_w = the weathering decay constant (a⁻¹); and

t_h = time between end of irrigation and harvest (a a⁻¹).

Other parameters are as indicated before. In case of root crops and tubers, the concentration of radionuclides in the external (above ground) parts of the plants is not relevant for consumption, but the concentration of the underground parts of the plants at harvest is. Only a certain fraction of the activity interception is assumed to reach these edible parts of the plant. This fraction is represented by a translocation factor ($Tf_{v,r}$).

$$C_{v,1,r} = C_{w,r} \times \frac{I_r}{T_{ir}} \times \frac{R}{Y} \times t_e \times Tf_{v,r} \quad (V.20)$$

In case of pasture, a perennial plant, also the growth period (t_{vg}) is considered (also in a a⁻¹). This results in the following formula:

$$C_{vg,1,r} = C_{w,r} \times I_r \times \frac{t_e}{T_{ir}} \times \frac{R}{Y} \times \frac{1 - \exp(-\lambda_w \times t_e)}{\lambda_w} \times \exp(-\lambda_w \times t_h) \times \frac{2(t_e + 2t_h)}{t_{vg}} \quad (V.21)$$

The last factor in this equation represents the fraction of the total grass production, which is contaminated through direct deposition during irrigation. For simplicity, it is assumed that the grass is growing at a constant rate during the growth period.

The radionuclide concentrations in plants are calculated from the ratios at equilibrium between the radionuclide concentration in the root soil zone and that in the plant due to root uptake:

$$C_{v,2,r} = \overline{C_{s,r}} \times B_{v,r} \quad \text{and} \quad C_{vg,2,r} = \overline{C_{s,r}} \times B_{vg,r} \quad (V.22)$$

where:

$C_{v,2,r}$ = concentration of radionuclide r in crop v due to root uptake (Bq kg⁻¹, fw);

$C_{vg,2,r}$ = concentration of radionuclide r in pasture due to root uptake (Bq kg⁻¹, dw);

$\overline{C_{s,r}}$ = concentration of radionuclide r in root zone soil, average over the year considered (Bq kg⁻¹);

$B_{v,r}$ = soil-to-plant concentration factor [kg dw (kg dw)⁻¹]; and

$B_{vg,r}$ = soil-to-pasture concentration factor [kg dw (kg dw)⁻¹].

The total radionuclide concentration in crops and pasture is given by:

$$C_{v,r} = C_{v,1,r} + C_{v,2,r} \quad \text{and} \quad C_{vg,r} = C_{vg,1,r} + C_{vg,2,r} \quad (V.23)$$

Radionuclides can be taken up by cattle and appear in contaminated milk and meat in three different ways:

- watering of the cattle with contaminated water;
- grazing of the cattle on pasture contaminated through irrigation; and
- uptake of contaminated soil by the cattle while grazing on the pasture.

The radionuclide concentrations in milk and meat are calculated directly from the radionuclide intakes by the cattle through factors determining the ratio between the radionuclide concentration milk and meat of the cattle and the daily radionuclide intake.

$$C_{mi,r} = [C_{w,r} \times U_{c_w} + (C_{vg,r} + \overline{C_{s,r}} \times X_s) U_{c_vg}] F_{mi,r} \quad (V.24)$$

where:

- $C_{mi,r}$ = concentration of radionuclide r in cow milk (Bq L⁻¹);
- $C_{w,r}$ = concentration of radionuclide r in water for the cattle (Bq m⁻³);
- U_{c_w} = daily water intake by dairy cows (m³ d⁻¹);
- $C_{vg,r}$ = concentration of radionuclide r in pasture or feed crops for the cattle (Bq kg⁻¹, dw);
- $\overline{C_{s,r}}$ = average concentration of radionuclide r in root zone soil, over the year concerned (Bq kg⁻¹);
- X_s = ratio of soil-to-pasture intake by the cattle (-);
- U_{c_vg} = daily pasture intake by dairy cows (kg dw d⁻¹); and
- $F_{mi,r}$ = cow to milk transfer factor (d L⁻¹).

The same formula can be used for calculating the concentration of radionuclide r in meat (Bq kg⁻¹), i.e.

$$C_{m,r} = [C_{w,r} \times U_{b_w} + (C_{vg,r} + \overline{C_{s,r}} \times X_s) U_{b_vg}] F_{m,r} \quad (V.25)$$

where:

- U_{b_w} = daily water intake by beef cattle (m³ d⁻¹);
- U_{b_vg} = daily pasture intake by beef cattle (kg dw d⁻¹);
- $C_{m,r}$ = concentration of radionuclide r in meat (Bq kg⁻¹);
- $F_{m,r}$ = meat transfer factor (d kg⁻¹).

V.1.7. Dealing with decay chains in the biosphere model

Short-lived daughter radionuclides (less than a few tenths of years) are assumed to come in equilibrium (the branching ratio always to be taken into account) with their longer-lived parent radionuclide in the biosphere. For the applicable exposure pathways the dose factor(s) of the daughter radionuclide(s) are added to that (those) of the parent radionuclide, assigning in this way the dose from the daughter to the parent radionuclide from which it is formed. In this case we implicitly assume that the behaviour of the parent and daughter radionuclide in the environment is similar.

For very short-lived daughter radionuclides (less than ½ hour) equilibrium is almost instantaneously realised, also in the human body. This means that the dose factors for inhalation and ingestion of the parent nuclide will already comprise the dose factors of the

daughter. Consequently the doses for inhalation and ingestion from these very short-lived daughter radionuclides are not taken into account. The dose factors of these radionuclides are only counted up to those of the parent radionuclides for the external exposure pathways.

The daughter radionuclides with intermediate half-life (larger than a few tenths of years) will only attain equilibrium with their parent radionuclide in the root zone soil, where the residence time of these radionuclides is sufficiently long. Consequently, for the exposure pathways passing through the soil, the dose factors of the daughter radionuclides may be added to those of the parent radionuclides. When the loss of daughter nuclides due to leaching may not be neglected in comparison to the radioactive decay, a reduction factor equal to the ratio of the radioactive decay constant with the effective decay constant (radioactive decay constant + environmental decay constant) is taken into account. This is the case for some daughter nuclides of ^{226}Ra , ^{210}Pb and ^{210}Po (daughters of ^{226}Ra) are leached to the deep soil before reaching equilibrium in the top soil. The concentrations of these daughter nuclides are calculated individually in this upper soil layer and multiplied by their proper soil-plant transfer factor to derive their concentration in the plants. Further in the model calculations they are treated as individual nuclides and multiplied with the proper dose conversion factor when deriving the annual effective dose.

V.1.8. Calculating the activity of daughter nuclides with intermediate half-lives

When dealing with daughter nuclides with a half-life greater than a few tenths of years and a parent nuclide with a long half-life, a certain ratio between the activities of the parent and daughter radionuclides is established in the soil. This ratio was calculated for the daughter radionuclides ^{210}Pb and ^{210}Po , both daughter radionuclides from ^{226}Ra . The method of determining this ratio is described here.

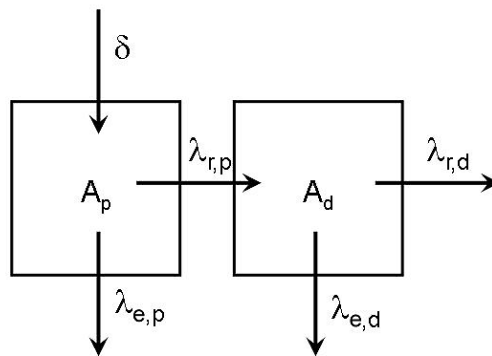

Fig. V.4. The production, transfer and loss processes for a parent and daughter radionuclide.

The rate of change of the activity of the parent nuclide is given by:

$$\frac{dA_p}{dt} = \delta - (\lambda_{e,p} + \lambda_{r,p}) \cdot A_p \quad (\text{V.26})$$

where:

δ = deposition rate of parent radionuclide through irrigation (Bq a^{-1});

A_p = activity of the parent radionuclide (Bq);
 A_d = activity of the daughter radionuclide (Bq);
 $\lambda_{e,p}$ = leaching rate constant of the parent radionuclide (a^{-1});
 $\lambda_{r,p}$ = decay constant of the parent radionuclide (a^{-1}); and
 t = time (a).

Integrating gives:

$$A_p(t) = \frac{\delta}{\lambda_{e,r,p}} \cdot [1 - \exp(-\lambda_{e,r,p} \cdot t)] \quad (V.27)$$

where:

$$\lambda_{e,r,p} = (\lambda_{e,p} + \lambda_{r,p}) \quad (V.28)$$

The rate of change of the activity of the daughter nuclide is given by:

$$\frac{dA_d}{dt} = \lambda_{r,p} \cdot A_p - (\lambda_{e,d} + \lambda_{r,d}) \cdot A_d \quad (V.29)$$

where:

$\lambda_{e,d}$ = leaching rate constant of the daughter radionuclide (a^{-1}); and
 $\lambda_{r,d}$ = decay constant of the daughter radionuclide (a^{-1}).

Integrating gives:

$$A_d(t) = \frac{\lambda_{r,p} \cdot \delta}{\lambda_{e,r,p} \cdot \lambda_{e,r,d}} \cdot \left[1 + \frac{\lambda_{e,r,p} \cdot \exp(-\lambda_{e,r,d} \cdot t) - \lambda_{e,r,d} \cdot \exp(-\lambda_{e,r,p} \cdot t)}{\lambda_{e,r,d} - \lambda_{e,r,p}} \right] \quad (V.30)$$

At equilibrium, when $t \gg \frac{1}{\lambda_{e,r,d}}$ and $t \gg \frac{1}{\lambda_{e,r,p}}$, then $(V.31)$

$$A_p(t) \approx \frac{\delta}{\lambda_{e,r,p}} \text{ and } A_d(t) \approx A_p(t) \cdot \frac{\lambda_{r,p}}{\lambda_{e,r,d}} \quad (V.32)$$

When using this equation for calculating the activity of daughter radionuclides of ^{226}Ra , one also needs to correct for the exhalation of ^{222}Rn . In this case the activity for ^{210}Pb , for instance, is given by:

$$A_{210\text{Pb}}(t) \approx A_{226\text{Ra}}(t) \cdot \frac{\lambda_{r,226\text{Ra}}}{\lambda_{e,r,210\text{Pb}}} \cdot 0.75 \quad (V.33)$$

The dose due to ingestion of drinking water and food crops is calculated by using:

$$H_{\text{ing},r,dw} = I_{dw} \cdot \sum_r [C_{dw,r} \cdot DF_{\text{ing},r}], \text{ and} \quad (V.34)$$

$$H_{ing,r,t} = \sum_t I_{food,t} \cdot \sum_r [C_{food,t,r} \cdot DF_{ing,r}], \quad (V.35)$$

where:

$H_{ing,r,x}$ = individual effective annual ingestion dose for adults ($Sv a^{-1}$):

for drinking water ($x = dw$), and for food product t ($x = t$);

I_f = annual individual consumption rate of substance f for adults ($f = dw$, or $x = t$) ($m^3 a^{-1}$ or $kg a^{-1}$);

$DF_{ing,r}$ = effective dose factor for ingestion of radionuclide r for adults ($Sv Bq^{-1}$)

External irradiation of the critical group is calculated using the following equations:

$$H_{ext,r,out} = C_{s,r} \cdot K_{out} \cdot T_{out} \cdot DRF_{ext,r} \quad (V.36)$$

$$H_{ext,r,in} = C_{s,r} \cdot K_{in} \cdot T_{in} \cdot DRF_{ext,r} \quad (V.37)$$

where:

$H_{ext,r,x}$ = individual effective annual dose for adults for external radiation from soil ($Sv a^{-1}$), where $x = in$ for inside, and $x = out$ for outside);

T_x = annual exposure time by soil ($h a^{-1}$) for adults, where $x = in$ for inside, and $x = out$ for outside);

K_x = shielding factor inside ($x = in$) and outside ($x = out$) the house; and

$DRF_{ext,r}$ = effective dose rate factor for external radiation by radionuclide r for adults ($Sv h^{-1} (Bq m^{-3})^{-1}$).

For the covered waste the external doses is corrected for the reduction in irradiation due to the shielding effect of the cover. This correction factor is defined as:

$$Corr_{ext}(t) = \exp[d_c(t_0) - t \cdot rer + t \cdot v_{Ra-226}]. \quad (V.38)$$

V.1.9. Results – concentrations of radionuclides in environmental media

For the calculation of the radionuclide concentrations in the exposing media, the processes of radioactive decay and ingrowth of the relatively "short"-lived daughter radionuclides, erosion and downward migration of the radionuclides (primarily due to leaching) are taken into account. Erosion reduces the thickness of the covering layer and through this, increases the exhaled ^{222}Rn concentration in the air and the external dose rate from the covered waste. However both effects are counteracted by the downward migration of the radionuclides. The resultant effect in the long term is an enhancement of the ^{222}Rn concentration in the air and of the external dose rate from the covered waste, with time.

The estimated concentrations of the important radionuclides are presented in the following tables.

Table V.3. ^{222}Rn concentrations in the air ($Bq m^{-3}$) due to exhalation from the waste.

Time	Uncovered waste		Covered waste	
	House 1	Field 1	House 1	Field 1
1a, 10a, 100a	354	11.8	7.08	0.236
1 000a	354	11.8	7.57	0.253
10 000a	354	11.8	13.6	0.453

Table V.4. ^{226}Ra concentrations in the waste (Bq kg^{-1}) for external irradiation.

Time	Uncovered waste		Covered waste	
	House 1	Field 1	House 1	Field 1
All	1000	1000	1000	1000

Table V.5. ^{238}U , ^{234}U , ^{230}Th , ^{226}Ra and ^{210}Pb concentrations in the resuspended dust (Bq kg^{-1}) for inhalation.

Time	Uncovered waste		Covered waste	
	House 1	Field 1	House 1	Field 1
All	5000	5000	0	0

Table V.6. Radionuclide concentrations in the well water (Bq m^{-3}).

Time	Uncovered waste and Covered waste / House 1 and Field 1			
	^{238}U , ^{234}U :	^{230}Th :	^{226}Ra :	^{210}Pb :
1, 10a	0	0	0	0
100a	4×10^{-20}	0	0	0
1000a	3.9×10^{-4}	3.35×10^{-18}	1.55×10^{-13}	4.21×10^{-13}
10 000a	1.25×10^3	2.79×10^{-03}	3.26×10^{-01}	6.16×10^{-1}

Table V.7. ^{222}Rn concentrations in the air due to exhalation from the waste (Bq m^{-3}).

Time	Uncovered waste		Covered waste	
	House 1	Field 1	House 1	Field 1
1a, 10a, 100a	354	11.8	7.08	0.236
1 000a	354	11.8	7.57	0.253
10 000a	354	11.8	13.6	0.453

Table V.8. ^{226}Ra concentrations in the waste (Bq kg^{-1}) for external irradiation.

Time	Uncovered waste		Covered waste	
	House 1	Field 1	House 1	Field 1
All	1000	1000	1000	1000

Table V.9. ^{238}U , ^{234}U , ^{230}Th , ^{226}Ra and ^{210}Pb concentrations in the resuspended dust (Bq kg^{-1}) for inhalation.

Time	Uncovered waste		Covered waste	
	House 1	Field 1	House 1	Field 1
All	5000	5000	0	0

V.1.9.1. Concentrations of the critical radionuclides on the waste

Table V.10. ^{222}Rn concentrations in the air due to exhalation from the waste (Bq m^{-3}).

Time	Uncovered waste		Covered waste	
	House 1	Field 1	House 1	Field 1
1a, 10a, 100a	354	11.8	7.08	0.236
1 000a	354	11.8	7.57	0.253
10 000a	354	11.8	13.6	0.453

Table V.11. ^{226}Ra concentrations in the waste (Bq kg^{-1}) for external irradiation.

Time	Uncovered waste		Covered waste	
	House 1	Field 1	House 1	Field 1
All	1000	1000	1000	1000

Table V.12. ^{238}U , ^{234}U , ^{230}Th , ^{226}Ra and ^{210}Pb concentrations in the resuspended dust (Bq kg^{-1}) for inhalation.

Time	Uncovered waste		Covered waste	
	House 1	Field 1	House 1	Field 1
All	5000	5000	0	0

Table V.13. Radionuclide concentrations in the well (Bq m^{-3}).

Time	Uncovered waste and Covered waste / House 1 and Field 1			
	^{238}U , ^{234}U :	^{230}Th :	^{226}Ra :	^{210}Pb :
1, 10a	0	0	0	0
100a	4×10^{-20}	0	0	0
1000a	3.9×10^{-4}	3.35×10^{-18}	1.55×10^{-13}	4.21×10^{-13}
10 000a	1.25×10^3	2.79×10^{-03}	3.26×10^{-01}	6.16×10^{-01}

Table V.14. ^{222}Rn concentrations in the air due to exhalation from the waste (Bq m^{-3}).

Time	Uncovered waste		Covered waste	
	House 1	Field 1	House 1	Field 1
1a, 10a, 100a	354	11.8	7.08	0.236
1 000a	354	11.8	7.57	0.253
10 000a	354	11.8	13.6	0.453

Table V.15. ^{226}Ra concentrations in the waste (Bq kg^{-1}) for external irradiation.

Time	Uncovered waste		Covered waste	
	House 1	Field 1	House 1	Field 1
All	1000	1000	1000	1000

Table V.16. ^{238}U , ^{234}U , ^{230}Th , ^{226}Ra and ^{210}Pb concentrations in the resuspended dust (Bq kg^{-1}) for inhalation.

Time	Uncovered waste		Covered waste	
	House 1	Field 1	House 1	Field 1
All	5000	5000	0	0

These tables present the concentrations of the radionuclides in the environment in the area near to house 1. Since this house is built above the waste, which is the source of all contamination, high concentration values are found in this zone. Radon concentrations are the highest when no cover is applied. The cover prevents resuspension of dust particles carrying radionuclides. Because an enhancement factor was used to calculate air dust concentration, these values were 5 times higher in comparison to the concentration in the soil. Furthermore, the concentration of radionuclides in the well near to house 1 was very low or even zero during the first 100 years.

V.1.9.2. Concentrations of the critical radionuclides outside the waste area

The following tables present the result for house 2. The environmental concentrations outside the waste area are lower on comparison to the concentrations on the waste area. The radioactive contaminated dust and radon concentration are lower due to dilution. The concentrations in the well near house 2 are also considerably lower by comparison with those near house 1.

Table V.17. ^{222}Rn concentrations in the air due to exhalation from the waste (Bq m^{-3}).

Time	Uncovered waste		Covered waste	
	House 2	Field 2	House 2	Field 2
1a, 10a, 100a	3.07	2.26	0.0613	0.0452
1 000a	3.07	2.26	0.0656	0.0484
10 000a	3.07	2.26	0.118	0.0868

Table V.18. ^{238}U , ^{234}U , ^{230}Th , ^{226}Ra and ^{210}Pb concentrations in the resuspended dust (Bq kg^{-1}) for inhalation.

Time	Uncovered waste		Covered waste	
	House 2	Field 2	House 2	Field 2
All	1300	950	0	0

Table V.19. All concentrations in the well (Bq m^{-3}).

Time	Uncovered waste and Covered waste / House 2 and Field 2			
	^{238}U , ^{234}U :	^{230}Th :	^{226}Ra :	^{210}Pb :
1, 10a	0	0	0	0
100a	4.04×10^{-27}	0	0	0
1000a	1.90×10^{-5}	$< 10^{-20}$	$< 10^{-20}$	0
10 000a	$3.23 \times 10^{+3}$	8.35×10^{-9}	8.72×10^{-3}	1.66×10^{-2}

V.1.10. Results – Annual Doses (Sv a^{-1})

V.1.10.1. Individual doses on the waste area

Table V.20. Inhalation of radon decay products due to exhalation of ^{222}Rn from the waste (Sv a^{-1}).

Time	Uncovered waste		Covered waste	
	House 1	Field 1	House 1	Field 1
1a, 10a, 100a	6.4×10^{-3}	1.1×10^{-4}	1.3×10^{-4}	2.1×10^{-6}
1 000a	6.4×10^{-3}	1.1×10^{-4}	1.4×10^{-4}	2.3×10^{-6}
10 000a	6.4×10^{-3}	1.1×10^{-4}	2.5×10^{-4}	4.1×10^{-6}

Table V.21. External irradiation from the radionuclides (^{226}Ra + daughters) in the waste (Sv a^{-1}).

Time	Uncovered waste		Covered waste	
	House 1	Field 1	House 1	Field 1
All	1.0×10^{-3}	1.2×10^{-3}	$< 10^{-12}$	$< 10^{-12}$

For covered waste: external dose rates increase with time due to decrease of cover thickness

Table V.22. Inhalation of resuspended dust ($^{238}\text{U}++^{234}\text{U} + ^{230}\text{Th} + ^{226}\text{Ra}+ + ^{210}\text{Pb}+$) from the waste (Sv a^{-1}).

Time	Uncovered waste		Covered waste	
	House 1	Field 1	House 1	Field 1
All	1.4×10^{-4}	4.5×10^{-4}	0	0

Table V.23. Ingestion of water from the well ($^{238}\text{U}+$, ^{234}U , $^{230}\text{Th}+$, $^{226}\text{Ra}+$ and $^{210}\text{Pb}+$) (Sv a^{-1}).

Time	Uncovered waste and Covered waste / House 1 and Field 1			
	^{238}U , ^{234}U	^{230}Th	^{226}Ra	^{210}Pb
1a,10a	0	0	0	0
100a	$< 10^{-12}$	0	0	0
1000a	7.64×10^{-12}	$< 10^{-12}$	$< 10^{-12}$	$< 10^{-12}$
10000a	2.45×10^{-5}	2.34×10^{-10}	3.65×10^{-8}	4.68×10^{-7}

Table V.24. Total doses on the waste area (Sv a^{-1}).

Time	Uncovered waste		Covered waste		Total Well
	House 1	Field 1	House 1	Field 1	
1a, 10a	7.5×10^{-3}	1.8×10^{-3}	1.3×10^{-4}	2.1×10^{-6}	0
100a	7.5×10^{-3}	1.8×10^{-3}	1.3×10^{-4}	2.1×10^{-6}	$< 10^{-12}$
1 000a	7.5×10^{-3}	1.8×10^{-3}	1.4×10^{-4}	2.3×10^{-6}	1.53×10^{-11}
10 000a	7.5×10^{-3}	1.8×10^{-3}	2.5×10^{-4}	4.1×10^{-6}	4.95×10^{-5}

For the impact on the waste area, the inhalation of radon exhaled from the waste is the critical pathway, in both cases: for the covered and uncovered waste, accept for the external irradiation in the uncovered field.

As mentioned before the modelling has also taken into account the effect of the processes of erosion and of downward migration of the radionuclides, on the doses from the covered waste.

The model also predicts that the residents in the houses above the waste, who would spend most of their time inside their house, are receiving a higher dose than the "associated workers".

V.1.10.2. Individual doses outside the waste area

Table V.25. Inhalation of radon decay products due to exhalation of ^{222}Rn from the waste (Sv a^{-1}).

Time	Uncovered waste		Covered waste	
	House 2	Field 2	House 2	Field 2
1a, 10a, 100a	5.6×10^{-5}	2.0×10^{-5}	1.1×10^{-6}	4.1×10^{-7}
1 000a	5.6×10^{-5}	2.0×10^{-5}	1.2×10^{-6}	4.4×10^{-7}
10 000a	5.6×10^{-5}	2.0×10^{-5}	2.1×10^{-6}	7.9×10^{-7}

Table V.26. Inhalation of resuspended dust ($^{230}\text{Th} +$ daughters) from the waste (Sv a^{-1}).

Time	Uncovered waste		Covered waste	
	House 2	Field 2	House 2	Field 2
All	3.6×10^{-5}	8.6×10^{-5}	0	0

Table V.27. Ingestion of water from the well ($^{238}\text{U} + ^{234}\text{U} + ^{230}\text{Th} + ^{226}\text{Ra} + \text{and } ^{210}\text{Pb}$) (Sv a^{-1}).

Time	Uncovered waste and Covered waste / House 2 and Field 2			
	$^{238}\text{U}, ^{234}\text{U}$	^{230}Th	^{226}Ra	^{210}Pb
<i>1a, 10a</i>	0	0	0	0
<i>100a</i>	$<10^{-12}$	0	0	0
<i>1000a</i>	$<10^{-12}$	0	$<10^{-12}$	0
<i>10000a</i>	6.34×10^{-5}	$<10^{-12}$	9.76×10^{-10}	1.26×10^{-8}

Table V.28. Total Doses outside the waste area (Sv a^{-1}); for these calculations, only ingestion of water was taken into account.

Time	Uncovered waste		Covered waste		Total Well
	<i>House 2</i>	<i>Field 2</i>	<i>House 2</i>	<i>Field 2</i>	
<i>1a, 10a</i>	9.2×10^{-5}	1.06×10^{-4}	1.1×10^{-6}	4.1×10^{-7}	0
<i>100a</i>	9.2×10^{-5}	1.06×10^{-4}	1.1×10^{-6}	4.1×10^{-7}	$<10^{-12}$
<i>1 000a</i>	9.2×10^{-5}	1.06×10^{-4}	1.2×10^{-6}	4.4×10^{-7}	$<10^{-12}$
<i>10 000a</i>	9.2×10^{-5}	1.06×10^{-4}	2.1×10^{-6}	7.9×10^{-7}	1.27×10^{-4}

For the impact from the uncovered waste, outside the waste area, the inhalation of resuspended dust is now the critical pathway for the "associated workers" (because of their occupation times on the fields outside and the high concentrations in the dust on the fields).

The "associated workers" are now also receiving a higher dose than the residents, spending most of their time inside their house. After 10,000 years the ingestion of drinking water also becomes an important pathway for the scenario of covered waste.

V.1.11. Concluding Tables/Graphs

Table V.29 and Figure V.6 show the time evolution of the total dose to individuals working near house 1 and house 2 for both covered and uncovered waste.

Table V.29. Time evolution of total doses (Sv a^{-1}); in this case ingestion of food products was not considered, only ingestion of contaminated well water.

Time	Uncovered waste		Covered waste	
	<i>House 1 + Field 1</i>	<i>House 2 + Field 2</i>	<i>House 1 + Field 1</i>	<i>House 2 + Field 2</i>
<i>1a, 10a, 100a</i>	9.3×10^{-3}	2.0×10^{-4}	1.3×10^{-4}	1.5×10^{-6}
<i>1 000a</i>	9.3×10^{-3}	2.0×10^{-4}	1.4×10^{-4}	1.6×10^{-6}
<i>5 000a</i>	9.3×10^{-3}	2.6×10^{-4}	2.2×10^{-4}	6.1×10^{-5}
<i>10 000a</i>	9.3×10^{-3}	3.2×10^{-4}	3.0×10^{-4}	1.3×10^{-4}

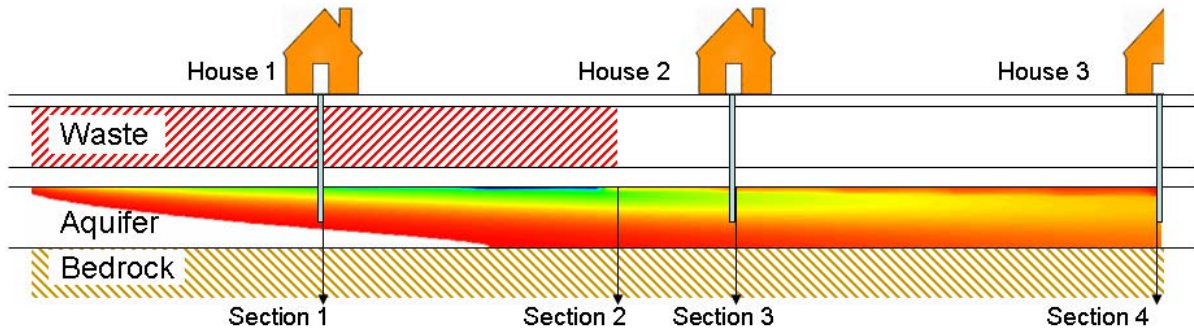

Fig. V.5. Graphical illustration of the conceptual model combined with an output file from HYDRUS 2D which determines the concentration in the aquifer after 10 000a. Low concentrations in the aquifer are coloured red (150 Bq m^{-3}), and the highest concentrations are coloured blue (18000 Bq m^{-3}). The concentration increases as the colour changes from red to orange to yellow to green to blue.

The concentration depends on the section and the depth in the soil. An overview of the concentration at four different locations is illustrated in Figure V.6.

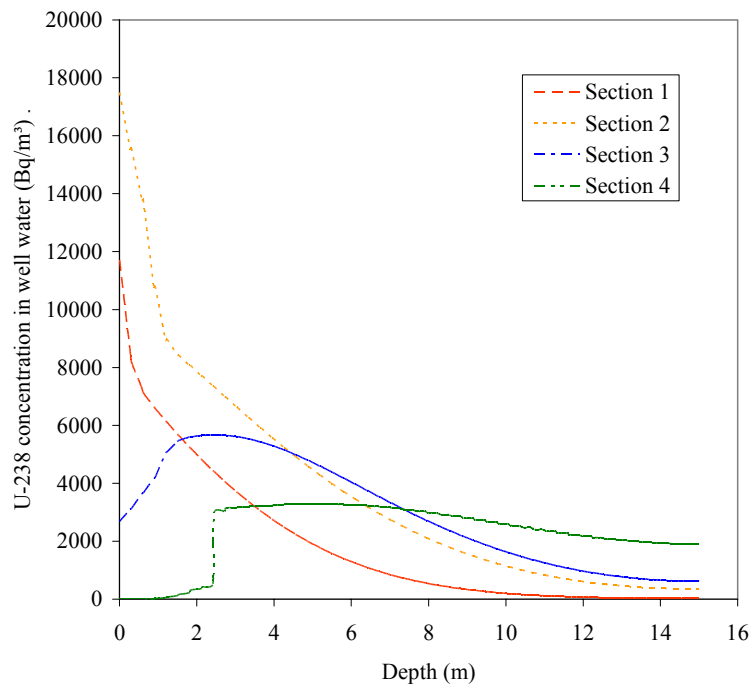

Fig. V.6. ^{238}U concentration in the well water (Bq/m^3) depending on the depth in the aquifer (m) and the section (see Figure V.5).

So far, the calculated doses have only included the atmospheric and ground water (advection) pathways. The food ingestion pathways may also give a significant contribution to the end dose, depending on the scenario considered. Therefore, calculations have been made to take into account the effect of ingestion of contaminated food crops; meat and milk. This

contamination may be caused by growing crops and pasture on contaminated land or by indirect contamination due to irrigation with contaminated water. The scenario of growing crops on contaminated soil is appropriate if it is assumed that the fields are irrigated with contaminated well water. Depending on the radionuclide, including these pathways should increase the predicted ingestion dose.

Contamination of the food products can be caused by two processes. Plants can be contaminated directly when they are grown on the waste. This is only possible in Field 1, when no cover is applied. Contamination of soil due to irrigation with contaminated water is valid for all fields. The following tables show the contribution from the different pathways. Table V.30 shows the increase in dose due to ingestion of food products, contaminated due to the use of contaminated irrigation water. In Table V.31 the doses due to cultivation directly on the waste are included.

Table V.30. Time evolution of total annual doses⁸ (Sv a⁻¹).

Time	Uncovered waste		Covered waste	
	House 1 + Field 1	House 2 + Field 2	House 1 + Field 1	House 2 + Field 2
<i>1a, 10a, 100a</i>	9.3×10^{-3}	2.0×10^{-4}	1.3×10^{-4}	1.5×10^{-6}
<i>1 000a</i>	9.3×10^{-3}	2.0×10^{-4}	1.4×10^{-4}	1.6×10^{-6}
<i>5 000a</i>	9.3×10^{-3}	2.8×10^{-4}	2.3×10^{-4}	8.8×10^{-5}
<i>10 000a</i>	9.4×10^{-3}	3.8×10^{-4}	3.2×10^{-4}	1.8×10^{-4}

For ²³⁸U and ²³⁴U the model predicts that the dose due to ingestion will increase by 45%, the ingestion of ²³⁰Th will increase the ingestion dose with 84%, and for ²²⁶Ra the ingestion dose will increase by 78% in comparison to the dose only due to ingestion of drinking water (data not shown). In the latter value the dose due to ingestion of ²¹⁰Pb contaminated food products is calculated implicitly.

Table V.31. Time evolution of total annual doses⁹ (Sv/a) considering all pathways.

Time	Uncovered waste		Covered waste	
	House 1 + Field 1	House 2 + Field 2	House 1 + Field 1	House 2 + Field 2
<i>1a, 10a, 100a</i>	1.2×10^{-2}	2.0×10^{-4}	1.3×10^{-4}	1.5×10^{-6}
<i>1 000a</i>	1.2×10^{-2}	2.0×10^{-4}	1.4×10^{-4}	1.6×10^{-6}
<i>5 000a</i>	1.2×10^{-2}	2.8×10^{-4}	2.3×10^{-4}	8.8×10^{-5}
<i>10 000a</i>	1.2×10^{-2}	3.8×10^{-4}	3.2×10^{-4}	1.8×10^{-4}

Direct contact of the plants with the radioactive waste is possible only on field 1 and then only with uncovered waste. This will give an additional dose to the residents of house 1 of 2.28×10^{-3} Sv a⁻¹ per Bq g⁻¹. Most of this dose is due to ²¹⁰Pb (54%) (+ 9% due to the daughter ²¹⁰Po). Ingestion of ²²⁶Ra in contaminated food is responsible for 23% of this dose, while ²³⁰Th, ²³⁸U and ²³⁴U are responsible for 12%, 1% and 1%, respectively.

⁸ Doses due to ingestion of food products contaminated due to growth on contaminated soil (waste) is not considered. Only contamination due to contaminated irrigation water is considered.

⁹ Doses due to ingestion of contaminated drinking water and food products, contaminated by irrigation and growth on a contaminated soil, are considered.

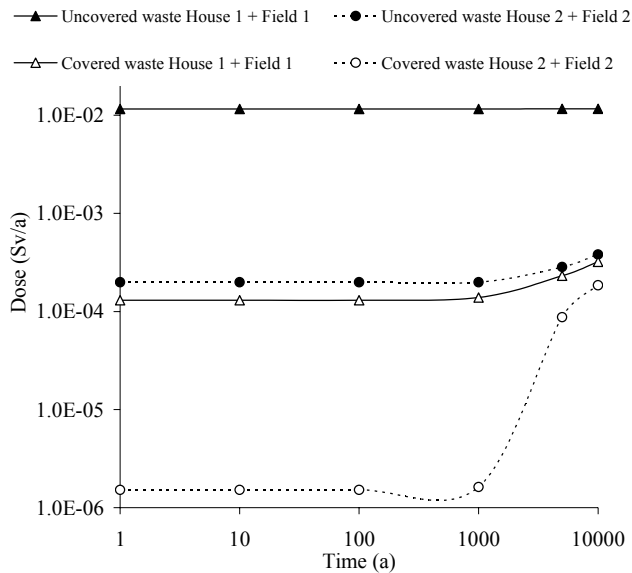

Fig. V.7. Illustration of the time evolution of the total annual doses (Sv a^{-1}). Ingestion of all food products contamination pathways were taken into account.

As can be seen from Figure V.7 and Figure V.8 the dose contribution due to the ingestion of contaminated food products is dependent on the scenario being considered. Living on and consuming products from the uncovered waste area clearly give the highest dose. Eating food products cultivated directly on contaminated soil gives an additional dose of 25%. In this case the dose caused by contamination due to irrigation is negligible (Figure V.8(a)). Living outside the uncovered waste area reduces the doses considerably (Figure V.8(b)). Maximal doses observed in Figure V.8(b) (i.e. doses after 10,000 years including all ingestion contamination pathways) are only 3.3 % of the maximal dose noted in Figure V.8(a). Observations for times less than 5,000 years give even lower values. In this scenario the effect of drinking contaminated water and eating contaminated food products is clearly visible. Drinking contaminated water gives an increase of 30 to 63 %, depending on the time frame. Combining this with the consumption of contaminated food products increases the dose by an additional 13 to 29 %.

The results of the calculations for the house build on covered waste resemble the ones of the calculations for the house build near the uncovered waste (Figure V.8(c)). In the first 100 years no contribution has been noted by ingestion of contaminated drinking water or food products. After 1000 year there is a slight contribution of the ingestion of drinking water (7%). The ingestion of food products becomes only important after 5000 year. This pathways gives an extra contribution of 12 and 17 %; respectively 5000 and 10000 years after construction of the waste piles. Because the waste is covered, no extra contribution was noted due to ingestion food products grown directly on the waste. In Figure V.8(d) the results of the calculations for house 2 built near to a covered waste pile are shown. As could be expected the overall contribution is much lower in comparison of the other scenarios. The influence of the ingestion of drinking water and food products is nevertheless important. After 5000 years the annual dose increased almost 40 times due to the ingestion of drinking water only. When also the ingestion of food products is taken into account, this increase is even more than a factor 50. After 10000 years the relative contribution of each pathway even doubles. Nevertheless these high relative values we have to remark that maximal doses observed in Figure V.8(d) are only 1.6 % of the maximal dose noted in Figure V.8(a).

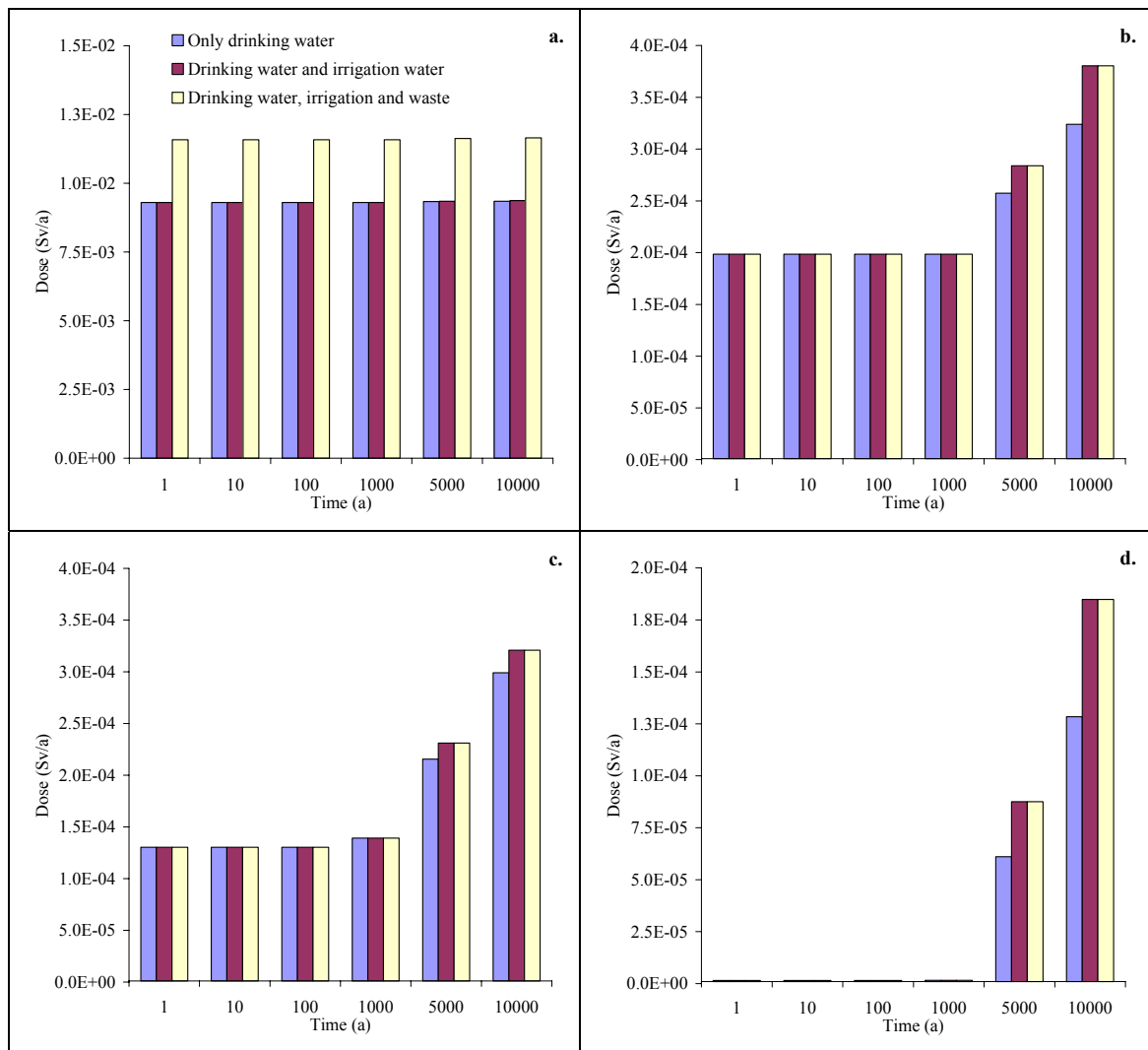

Fig. V.8. Time evolution of the total doses (Sv a^{-1}). The dose due to radon and resuspended dust inhalation, external irradiation, and ingestion of drinking water is marked blue. Addition of dose due to ingestion of irrigation practices is marked red. Considering all pathways (including dose due to growth on the waste) is marked yellow. The different graphs illustrate: residence in zone 1 (house 1 and field 1) with uncovered waste (a); residence in zone 2 (house 2 and field 2) with uncovered waste (b); residence in zone 1 with covered waste (c); and residence in zone 2 with covered waste (d).

V.2. RESRAD (onsite), RESRAD-OFFSITE

V.2.1. RESRAD (onsite)

This model ([28], [29]) was designed to handle situations such as buried waste and landfill (uncovered waste). It has limited source region geometry, and cannot directly predict off-site impacts. However, the model can be used to make indirect estimates of off-site impacts, so the model is very useful as a screening tool for off-site impacts in situations where no other models are available. The model handles a wide range of nuclides, and allows users to change the cut-off half-life for setting short-lived daughters in equilibrium.

V.2.2. RESRAD-OFFSITE

This model employs a similar approach to that used in RESRAD (onsite), but allows for the assessment of off-site impacts ([30], [31]). Allowance is also made for the effects of surface water bodies and for variations in land use near the disposal site. The quantity of data required for this model is very much larger than for RESRAD (onsite), but the use of this model provides greater flexibility when carrying out assessments.

V.2.2.1. RESRAD-OFFSITE results for House #2

The waste was divided into 200m by 200m blocks. The off-site doses were calculated for each block, and the results for each block were added to produce the doses for the total waste. The input data were taken from the tables in the scenario description section. Where values for model parameters were not specified in the scenario description, the default values supplied by the model itself were used in the calculations.

The results are shown in the following figures.

Original wind rose – covered waste

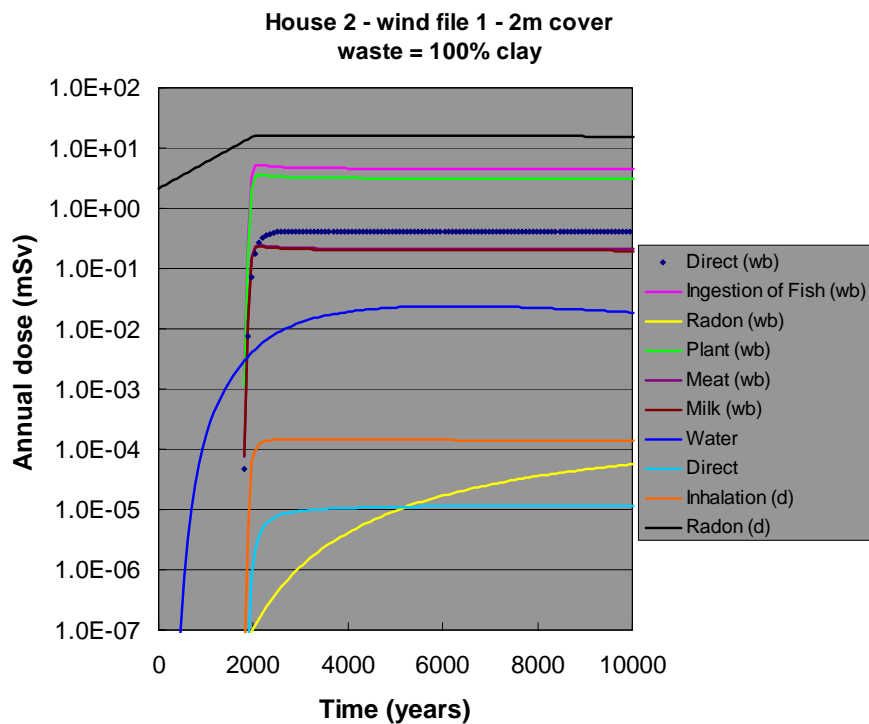

Fig. V.9. Annual dose as a function of time for the area source scenario with the original wind rose (prevailing wind direction parallel to the direction of groundwater flow) and 2 metres of cover above the waste. The waste is assumed to consist of 100% clay.

Figure V.9 shows that the dominant exposure pathway is inhalation of radon exhaled from the waste. The large dose contribution from ingestion of fish is not consistent with the location of the surface water body and the direction of groundwater flow.

**House 2 - wind 1 - 2m cover
waste = 80% sand + 20% clay**

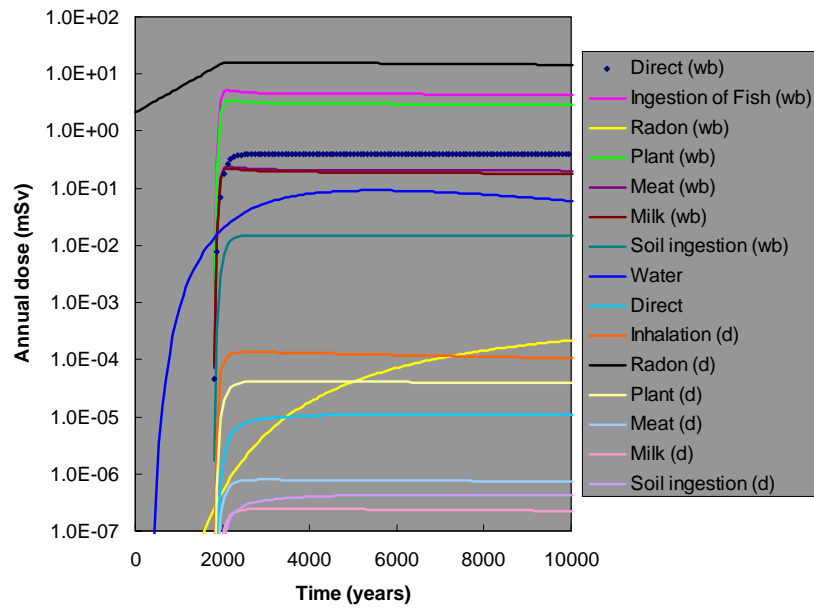

Fig. V.10. Annual dose as a function of time for the area source scenario with the original wind rose (prevailing wind direction parallel to the direction of groundwater flow) and 2 metres of cover above the waste. The waste is assumed to consist of 20% clay and 80% sand.

A comparison of Figure V.10 with Figure V.9 shows that this model predicts that changing the composition of the waste from 100% clay to a mixture of 20% clay and 80% sand results in the loss of more radionuclides from the waste, particularly by leaching. The contributions from most of the other exposure pathways are not predicted to change significantly.

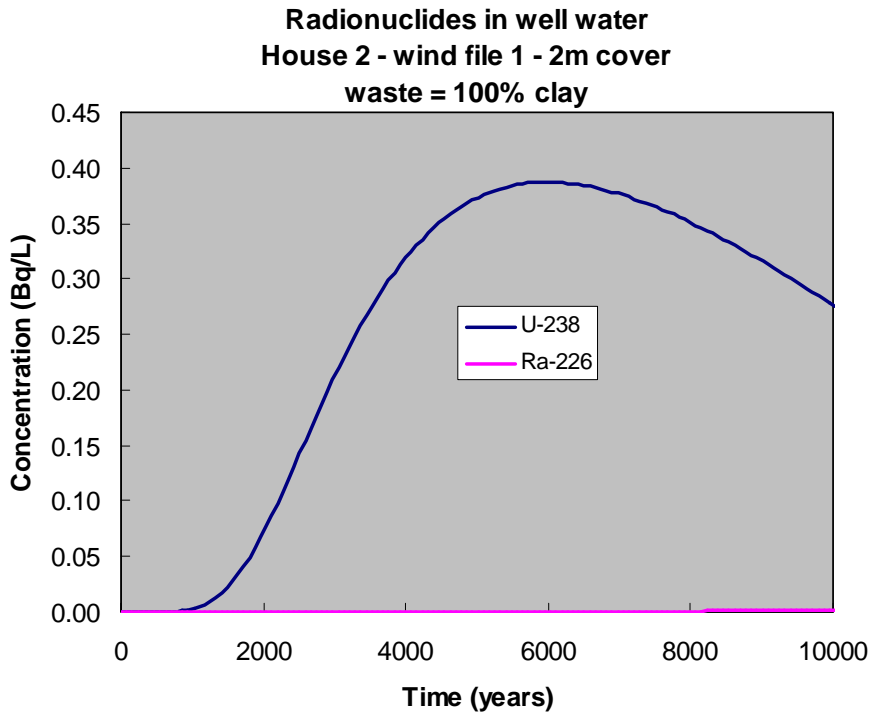

Fig. V.11. Concentrations of ^{238}U and ^{226}Ra in well water for the same situation as in Figure V.9.

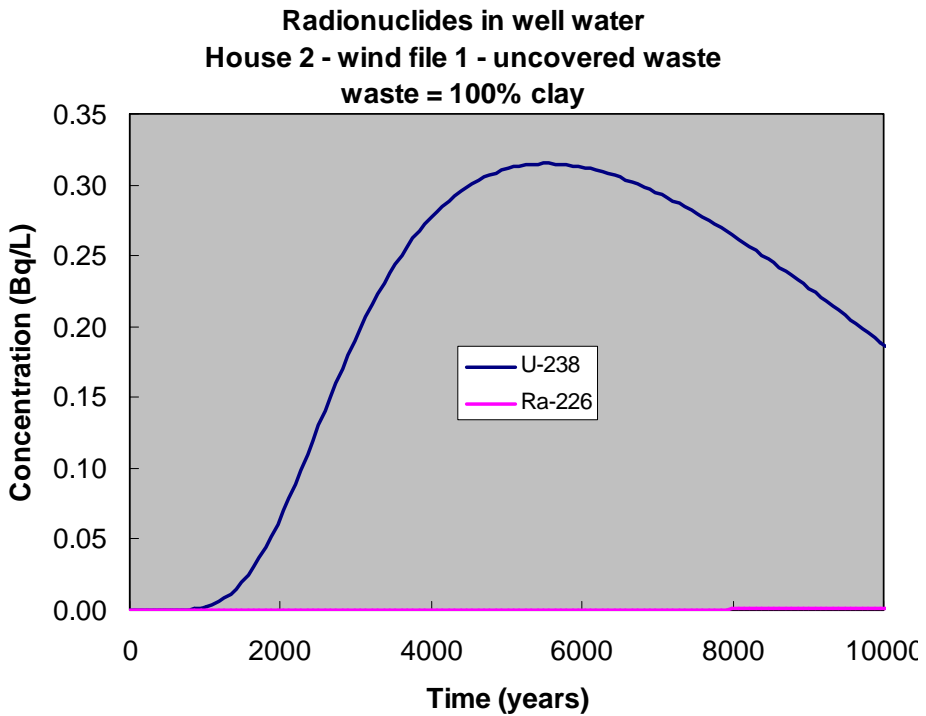

Fig. V.12. Concentrations of ^{238}U and ^{226}Ra in well water for the same situation as in Figure V.10

The concentrations of ^{238}U and ^{226}Ra in well water are shown for the case where the waste consists of 100% clay and the waste is covered (Figure V.13) and not covered (Figure V.14). A comparison of these two figures shows that the peak ^{238}U concentration in the case where there is no cover is lower in magnitude than for the case where the waste is covered, but occurs at approximately the same time (after 600 years). The lower peak concentration in the uncovered waste case is probably due to removal of some of the waste by erosion. In both cases, the thickness and composition of the unsaturated layer between the bottom of the waste and the top of the aquifer are the same so the time taken for radionuclides leached from the waste to traverse the unsaturated layer should be the same.

Original wind rose – uncovered waste

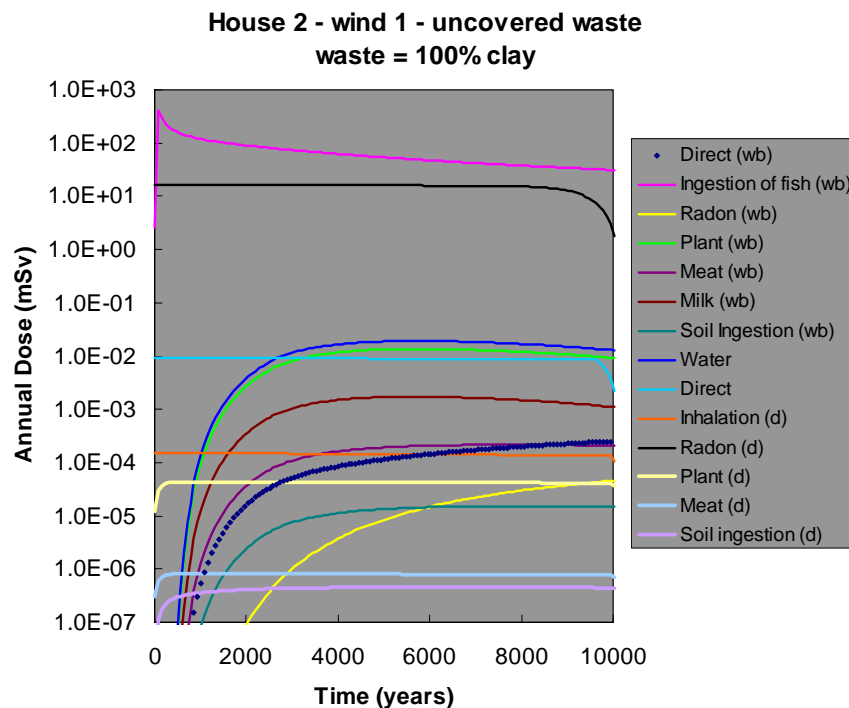

Fig. V.13. Annual dose as a function of time for the area source scenario with the original wind rose (prevailing wind direction parallel to the direction of groundwater flow) and no cover above the waste. The waste is assumed to consist of 100% clay.

A comparison of Figure V.13 with Figure V.9 shows that the dose contributions from the airborne pathways (radon inhalation, dust inhalation, etc) increase significantly when the waste is not covered, and begin to decrease when the thickness of the waste is reduced significantly by erosion. This decrease due to erosion of the waste is not shown in Figure V.9, presumably because the time span of the calculations is not long enough.

Wind rose rotated 90 degrees – covered waste

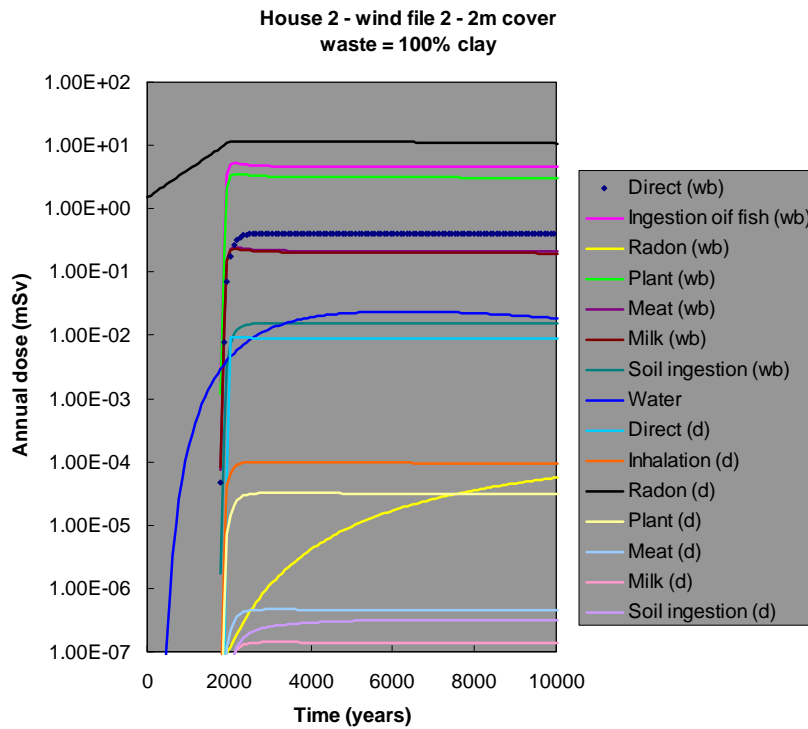

Fig. V.14. Annual dose as a function of time for the area source scenario with the original wind rose rotated 90 degrees (prevailing wind direction perpendicular to the direction of groundwater flow and towards the surface water body) and 2 metres of cover above the waste. The waste is assumed to consist of 100% clay.

Comparison of Figure V.14 with Figure V.13 shows that the dose from exhaled radon is reduced when the wind rose is rotated (as expected), whereas the dose contributions from the waterborne pathways remain the same (again as expected).

Wind rose rotated 180 degrees – covered waste

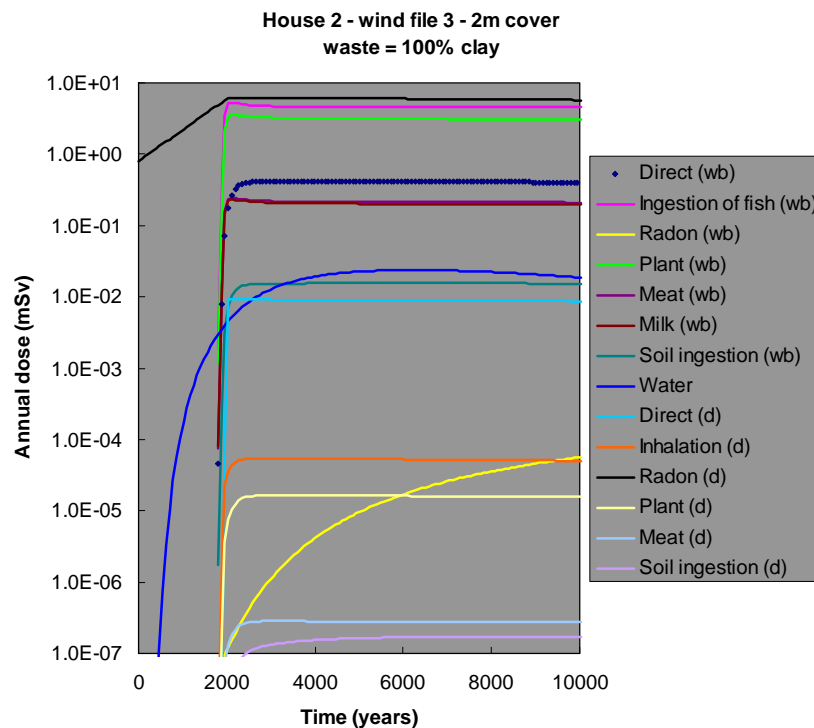

Fig. V.15. Annual dose as a function of time for the area source scenario with the wind rose rotated 180 degrees (prevailing wind direction opposite to the direction of groundwater flow) and 2 metres of cover above the waste. The waste is assumed to consist of 100% clay.

V.2.3. Summary for House #2

Figure V9 to Figure V.15 show the calculated doses for the house 200 m from the edge of the waste. The qualitative features of interest are:

- the doses resulting from the groundwater pathways are the same in each case, which is what is expected;
- the effect of cover is to reduce the doses resulting from the airborne pathways, as expected;
- rotating the wind rose 90 degrees reduces the doses resulting from the airborne pathways, as expected;
- the model predicts that the radon doses will increase with time for covered waste, and decrease with time for uncovered waste; this is consistent with the expected effects due to erosion of the cover (covered waste) and erosion of the waste (uncovered waste).

V.2.4. RESRAD-OFFSITE results for House #3

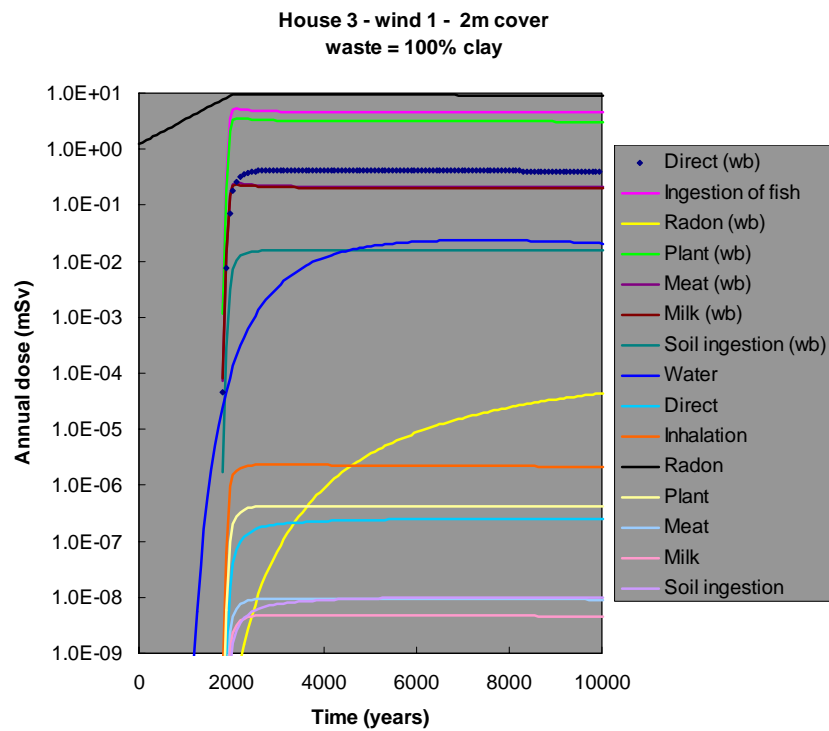

Fig. V.16. Annual dose as a function of time for the area source scenario with the original wind rose (prevailing wind direction parallel to the direction of groundwater flow) and 2 metres of cover above the waste. The waste is assumed to consist of 100% clay.

A comparison of Figure V.16 with Figure V.9 shows that the model predicts that the effect of increasing the distance of the house from the waste is to reduce the dose contributions from all pathways, as expected.

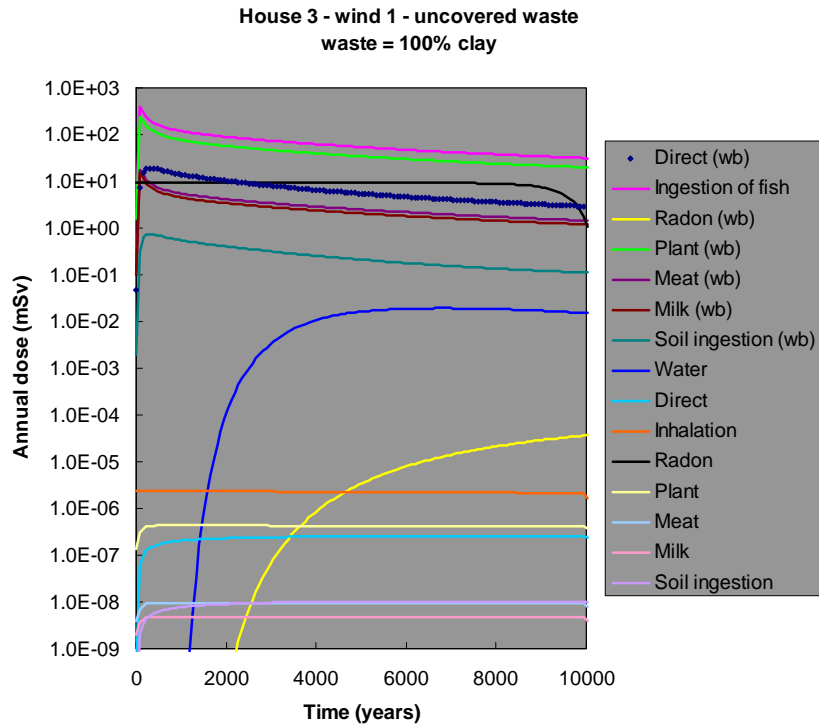

Fig. V.17. Annual dose as a function of time for the area source scenario with the original wind rose (prevailing wind direction parallel to the direction of groundwater flow) and no cover above the waste. The waste is assumed to consist of 100% clay.

Comparing Figure V.17 with Figure V.13 shows that the model predicts that the dose contributions from the direct pathways (external exposures) are lower for House #3 than for House #2, which is consistent with the fact that House #3 is further from the waste pit than is House #2.

The large contribution from the fish ingestion pathway appears to be a problem with the location of the surface water body.

V.2.5. PRESTO

One modeller used PRESTO and compared the predictions from PRESTO with those from RESRAD (onsite) and RESRAD-OFFSITE. PRESTO ver.4.2 (Prediction of Radiological Effects Due to Shallow Trench Operations) is a computer model for evaluating radiation exposure from contaminated soil layers on site as well as off site.

Table V.32. Values of K_d used in the calculations.

Nuclide	Waste	Unsaturated zone	Saturated zone
uranium	33	326	33
thorium	3000	3480	3000
radium	490	2190	490
Lead	270	340	270
polonium	150	660	150

PRESTO incorporates the following features:

- the same K_d values for parent and daughter radionuclides in decay chains;
- a correction to account for multi-phase leaching processes under field conditions;
- one unsaturated zone;
- a two dimensional dispersion groundwater model;
- an air dispersion model;
- seasonality effects in the groundwater movement;
- simulation time is limited to 10,000 years

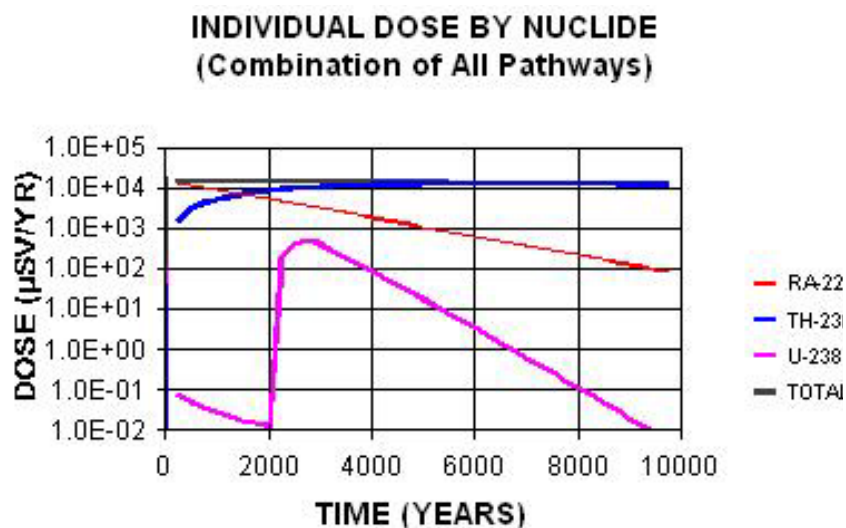

Fig. V.18. PRESTO doses for House #1 and uncovered waste.

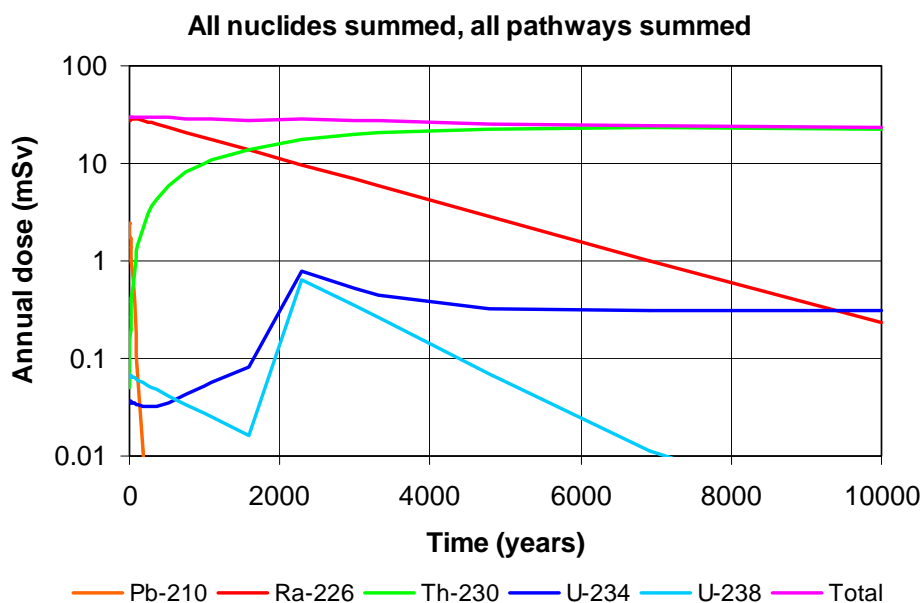

Fig. V.19. RESRAD (onsite) doses for House #1 and uncovered waste.

Comparison of Figures V.20 and V.21 shows that the peak doses occur at approximately the same time for both models. However, PRESTO appears to predict lower doses than RESRAD (onsite). This suggests that PRESTO (which appears to be the simpler model) is not conservative.

The contributions of the radon and the drinking water doses are similar.

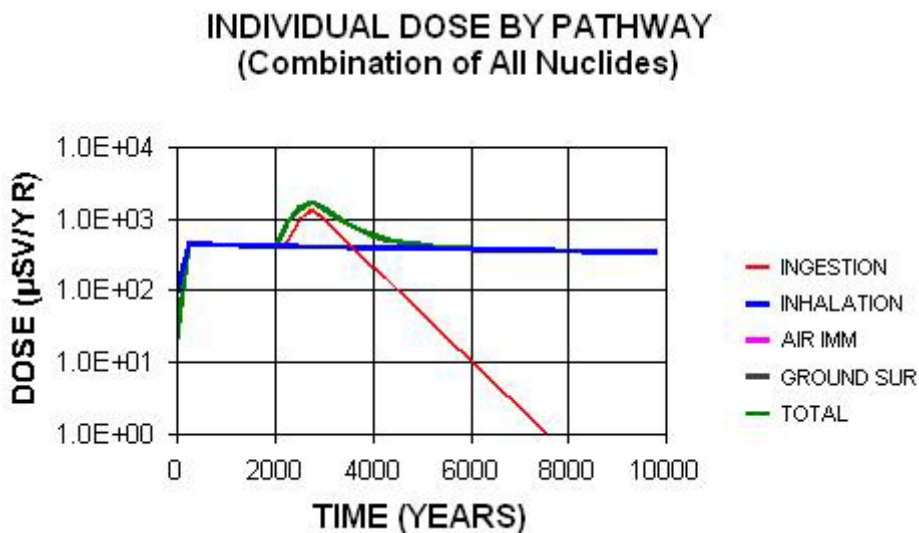

Fig. V.20. PRESTO doses for House #1 for covered waste (2 m of cover).

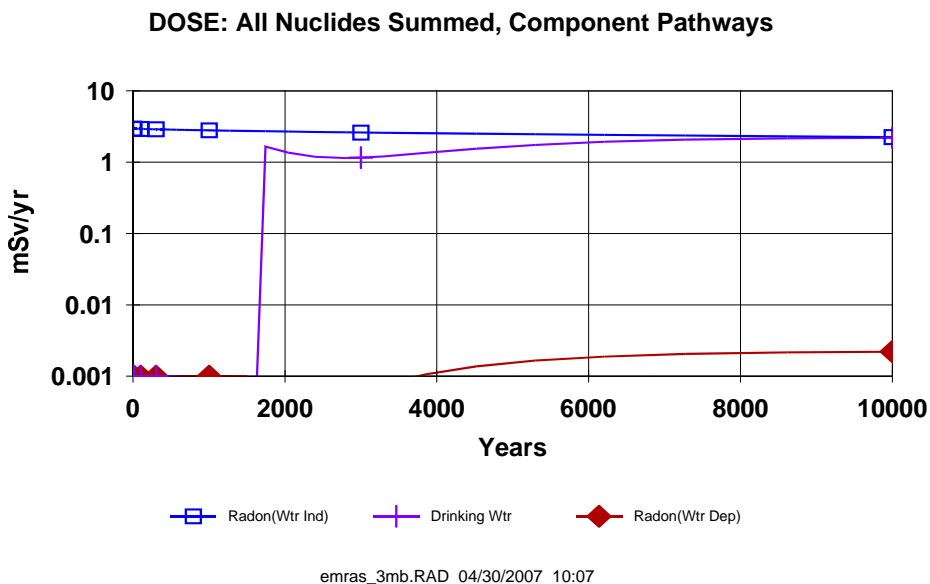

Fig. V.21. RESRAD (onsite) doses for House #1 for covered waste (2 m of cover).

In this case, the doses calculated by RESRAD for drinking water are similar to those calculated by PRESTO. However, PRESTO does not give the dose from inhalation of radon and radon progeny, which is predicted by RESRAD to be the largest component of the total dose.

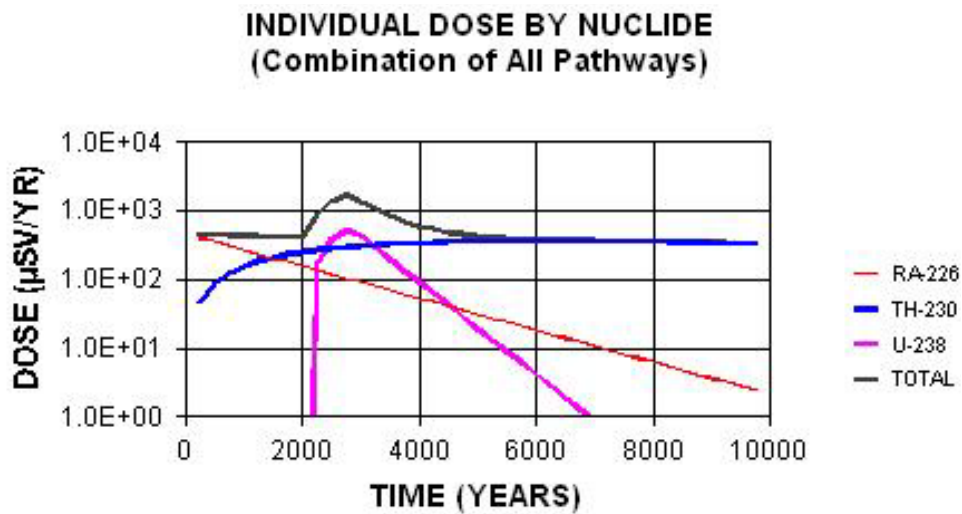

Fig. V.22. PRESTO results for each nuclide for covered waste (2 m of cover).

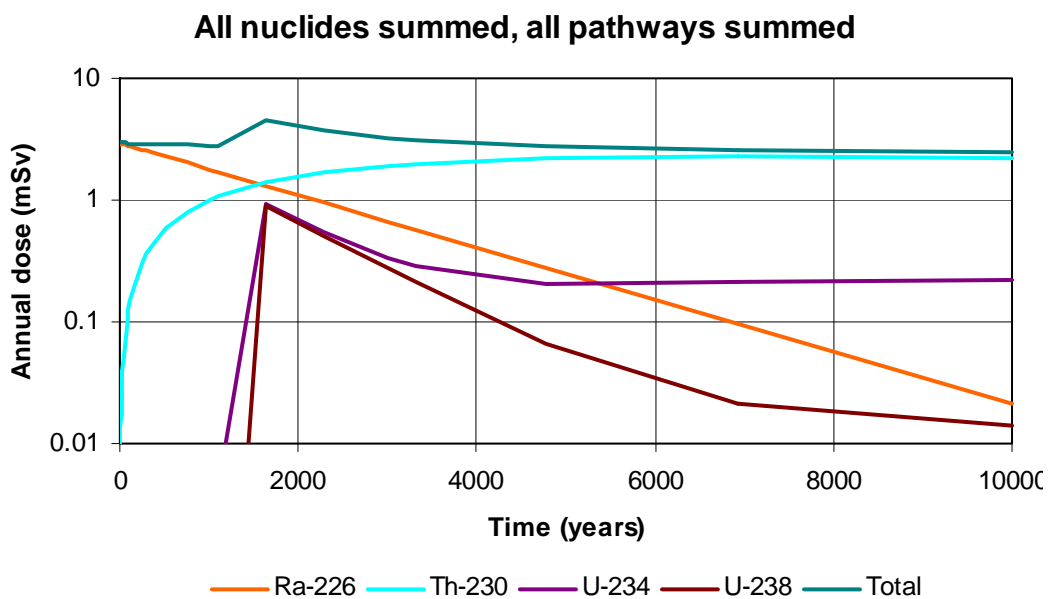

Fig. V.23. RESRAD (onsite) results for each nuclide for covered waste (2m of cover).

In this case, the RESRAD doses appear to be higher, by a factor of approximately 6. The reason for this difference is not understood.

INDIVIDUAL DOSE BY NUCLIDE (Drinking Water Dose)

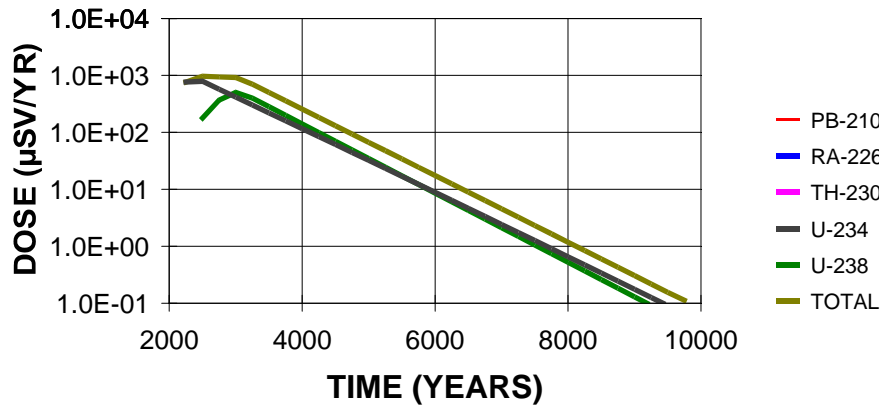
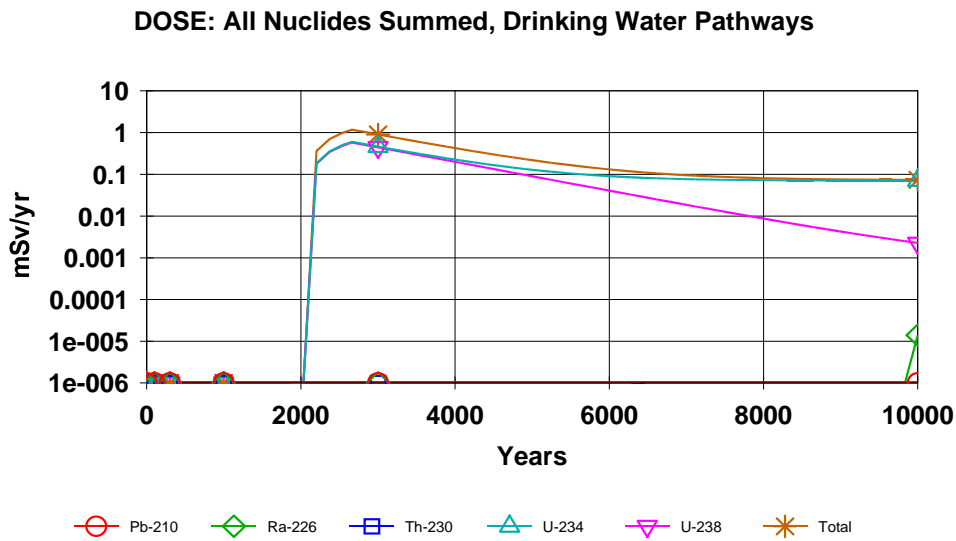

Fig. V.24. PRESTO results for the drinking water dose for an occupant of House #2 for covered waste (2 m of cover).



emras_5b1.RAD 04/24/2007 10:44 Includes All Pathways

Fig. V.25. RESRAD results for the drinking water dose for an occupant of House #2 for covered waste (2 m of cover).

In this case the predicted peak dose is approximately the same for both models and the peak occurs at approximately the same time for both models. However RESRAD predicts higher doses than PRESTO from drinking water for large times.

APPENDIX VI. TESTING OF HYPOTHETICAL AREA SOURCE PLUS RIVER SCENARIO

VI.1. RESRAD-OFFSITE

The only model used for testing this scenario was RESRAD-OFFSITE. The results for houses #1 and #2 from the area source scenario are also applicable to this scenario, as the layout of the site with respect to these two houses is the same in both scenarios, and the presence of the river should not affect the results for houses #1 and #2. Therefore the results presented below for houses #1 and #2 from the area source plus river scenario can be compared with the results from the area source scenario.

VI.1.1. Results for house #1

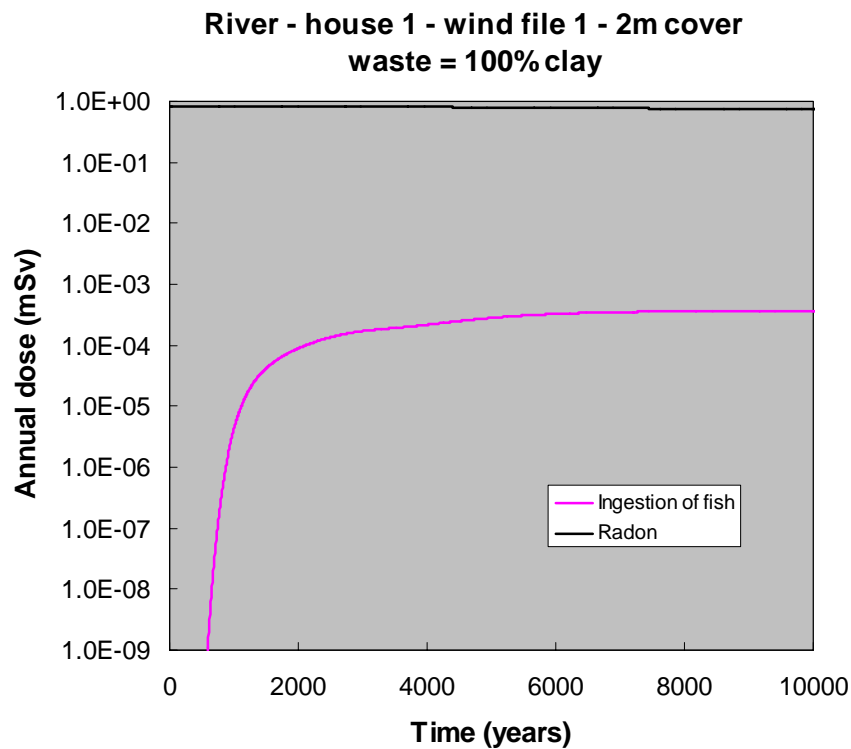

Fig. VI.1. Dose contributions for different pathways for house #1 with the original wind rose and waste consisting of 100% clay.

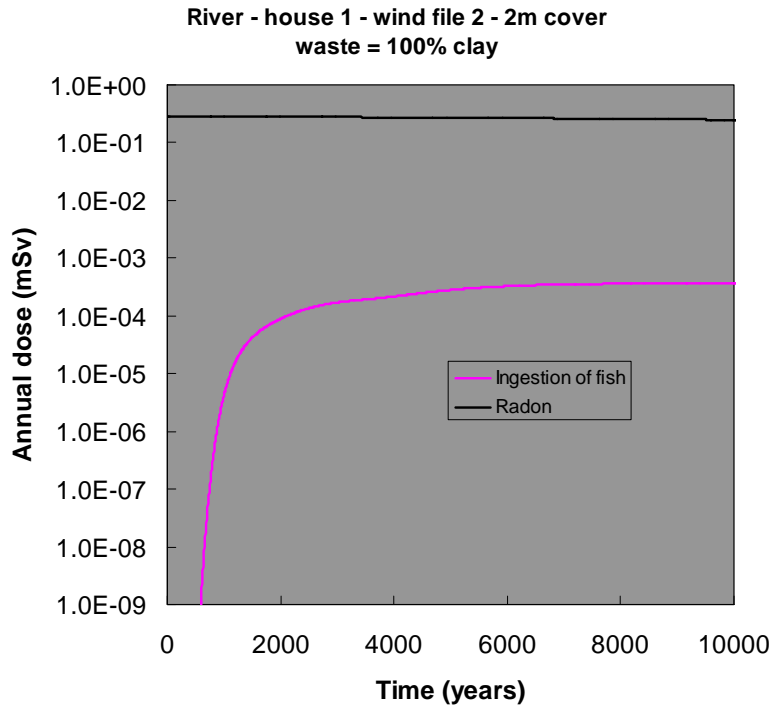

Fig. VI.2. Dose contributions for different pathways for house #1 with the original wind rose and waste consisting of 100% clay.

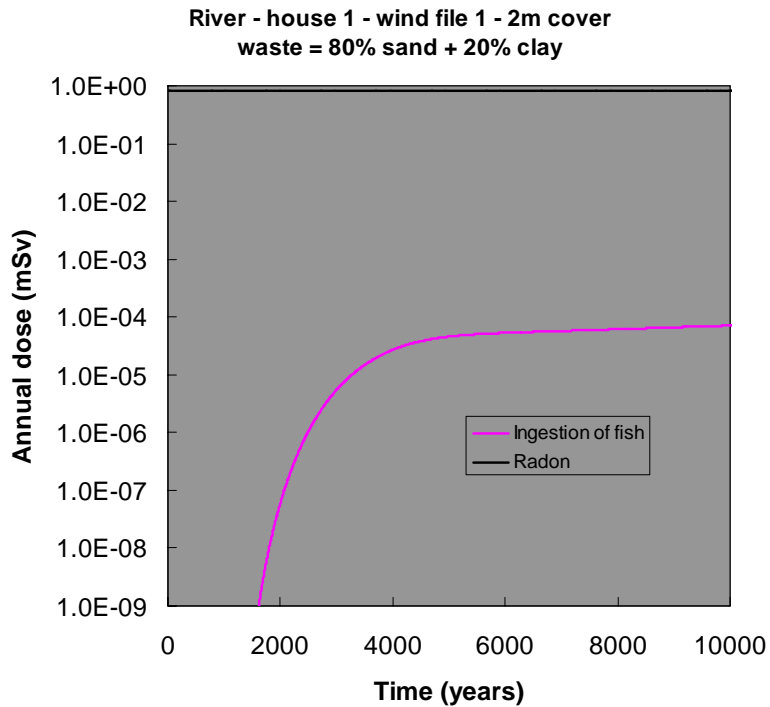

Fig. VI.3. Dose contributions for different pathways for house #1 for the original wind rose and waste consisting of 80% sand plus 20% clay.

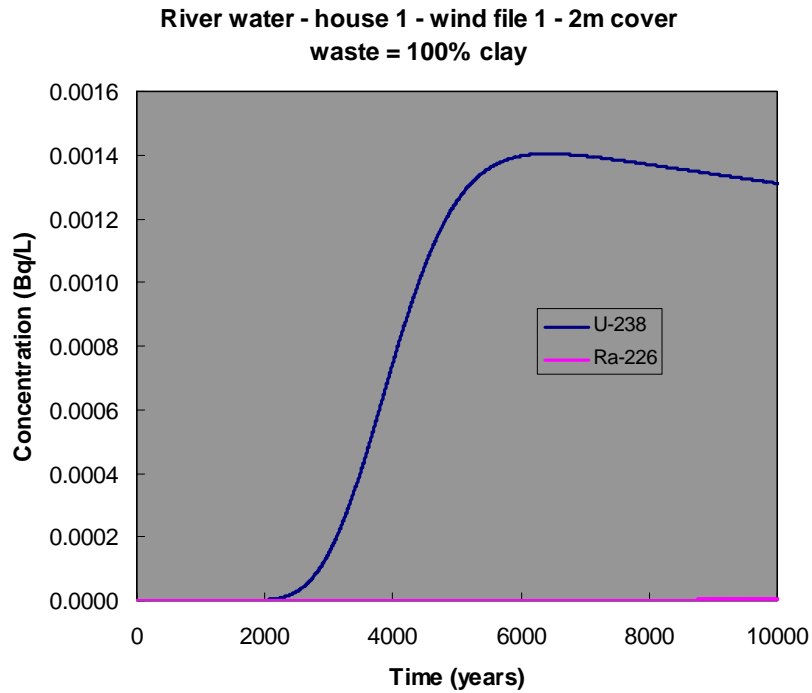

Fig. VI.4. Concentration of ^{238}U and ^{226}Ra in river water at the location of house #1, for the original wind rose and for waste consisting of 100% clay with 2 metres of cover.

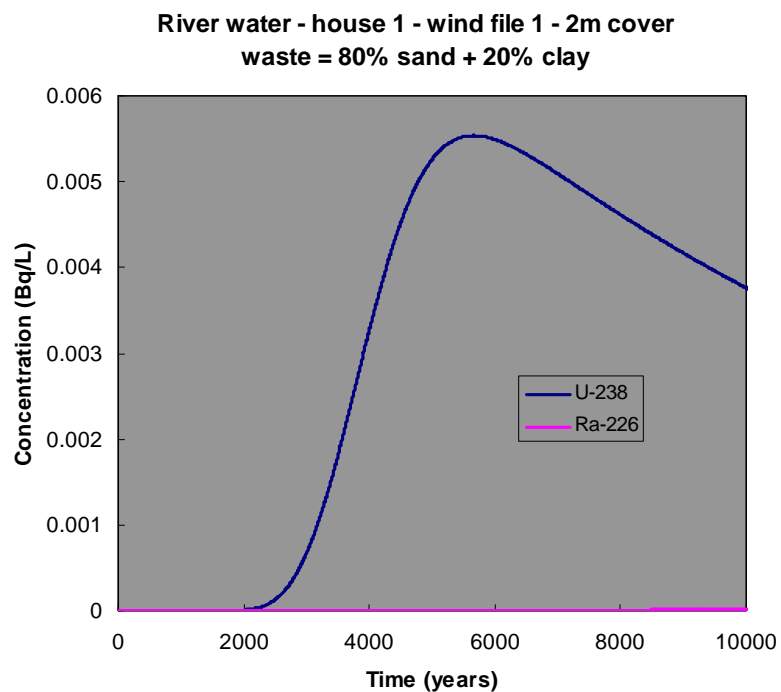

Fig. VI.5. Concentrations of ^{238}U and ^{226}Ra in river water at the location of house #1, for the original wind rose and for waste consisting of 80% sand plus 20% clay with 2 metres of cover.

Comparing Figure VI.5 and Figure VI.4 shows that the model predicts that the effect of changing the composition of the waste from 100% clay to 80% sand plus 20% clay is to increase the leaching of radionuclides into the river water by a factor of approximately 3–4.

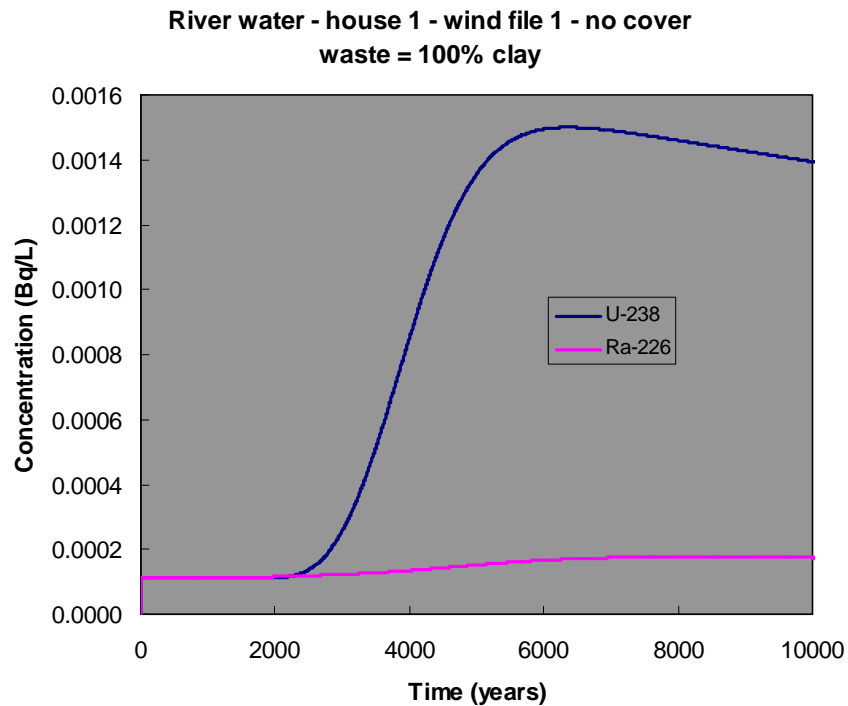

Fig. VI.6. Concentrations of ^{238}U and ^{226}Ra in river water at the location of house #1, for the original wind rose and for waste consisting of 100% clay with no cover.

Comparing Figure VI.6 and Figure VI.4 shows that the model predicts that removing the cover does not have a significant effect on the maximum concentration of ^{238}U in river water; however, removing the cover does affect the concentration in the first 200 years, due to surface runoff removing waste and washing it into the river.

VI.1.2. Results for house #2

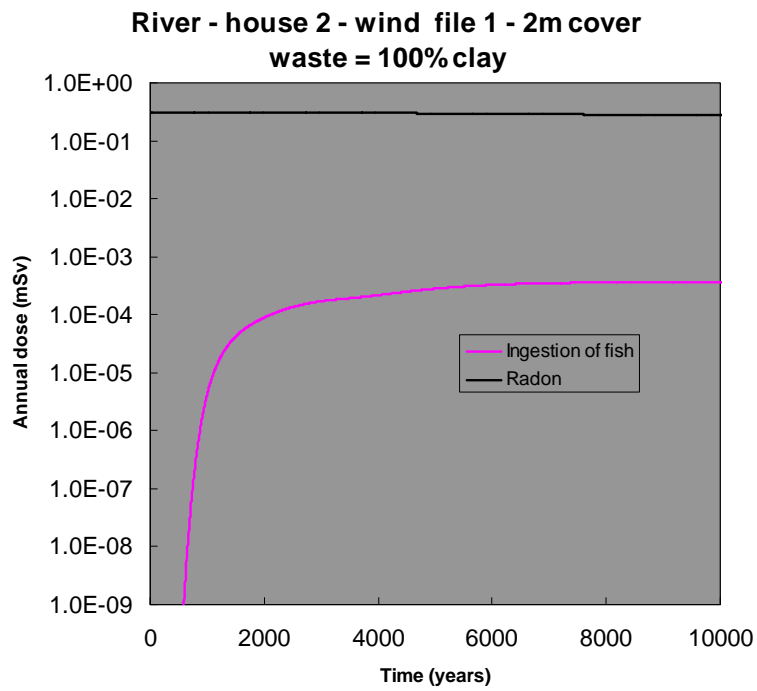

Fig. VI.7. Dose contributions for different pathways for house #2 with the original wind rose and waste consisting of 100% clay.

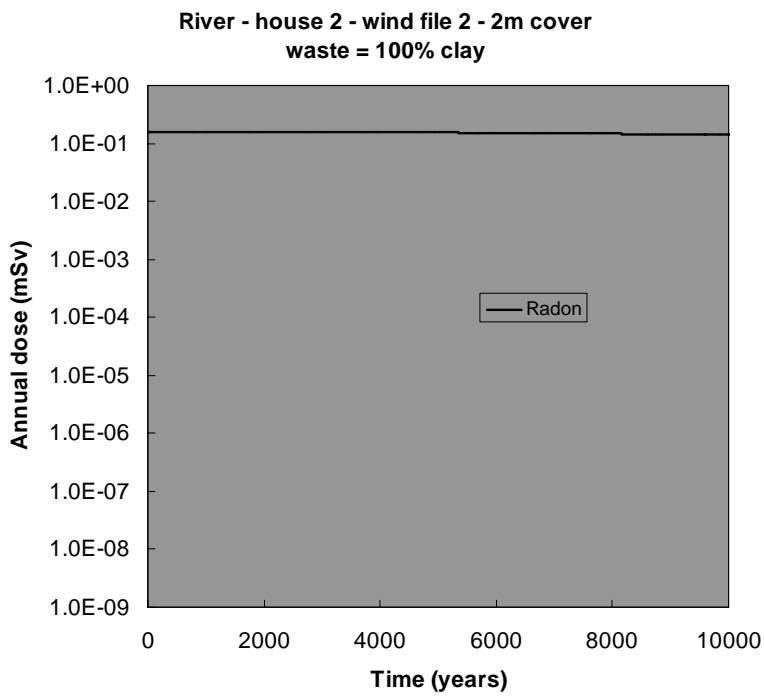

Fig. VI.8. Dose contributions for different pathways for house #2 with the wind rose rotated 90 degrees and waste consisting of 100% clay.

The predicted effect of rotating the wind rose ninety degrees for house #2 can be seen by comparing Figure VI.8 with Figure VI. 7. The model predicts that the only pathway which makes any contribution to the total annual dose is inhalation of radon, and the contribution from this pathway is reduced relative to the case of the original wind rose.

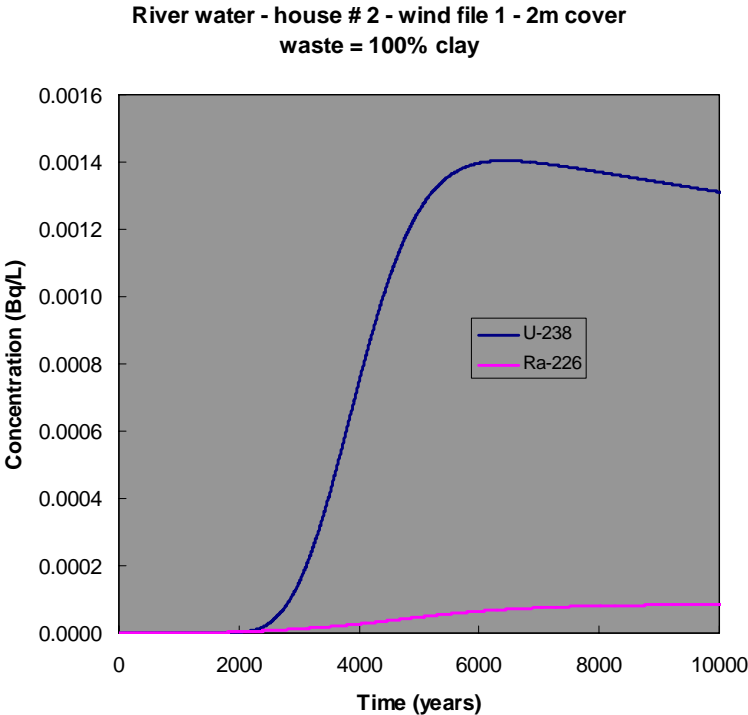

Fig. VI.9. Dose contributions for different pathways for house #2 with the wind rose rotated 90 degrees and waste consisting of 100% clay.

APPENDIX VII. DESCRIPTION OF REAL SCENARIOS

VII.1. Lignite power plant (LPP II)

VII.1.1. Power plant description

In Greece, about 70% of the installed capacity of electrical energy is produced from two main lignite power plants (LPPI: 3020 MW and LPPII : plant A 550 MW and plant B 300 MW).

LPPII (Figure 1) is near a small city, with 10,000 inhabitants, that is located about 2.5 and 4 km SE from the lignite power plants A and B, respectively [65].

Plant A consists of three lignite burning, steam electric generating units I, II and III, rated power 125, 125 and 300 MWe, respectively, and has operated since the early 1970s. Plant B is newer, operating since the early 1990s, and consists of one unit of 300 MWe. The lignite deposit is of very low calorific value ($960\text{--}1385\text{ kcal kg}^{-1}$) and of high water and ash content (60% and 17%, respectively). At full load, the units consume about $22\text{--}25 \times 10^6$ kg of pulverized lignite per day. Most of the produced fly ash is collected by electrostatic filters, which have a design collection efficiency of 99.6%, but in practice it falls to 95–96%.

The data refer to a sampling period lasting 1 year from February 1997 to January 1998. The results, which are presented, include monthly values of dust amount, and ^{238}U activities in all of the collected fallout samples, as well as the mean annual values of ^{232}Th activity in the nearest city sampling sites.

Plant A has 3 units with 3 stacks: (I), (II) with height 120 m and (III) with height 150 m. Plant B has one unit with one stack, assumed to have a height of 130 m.

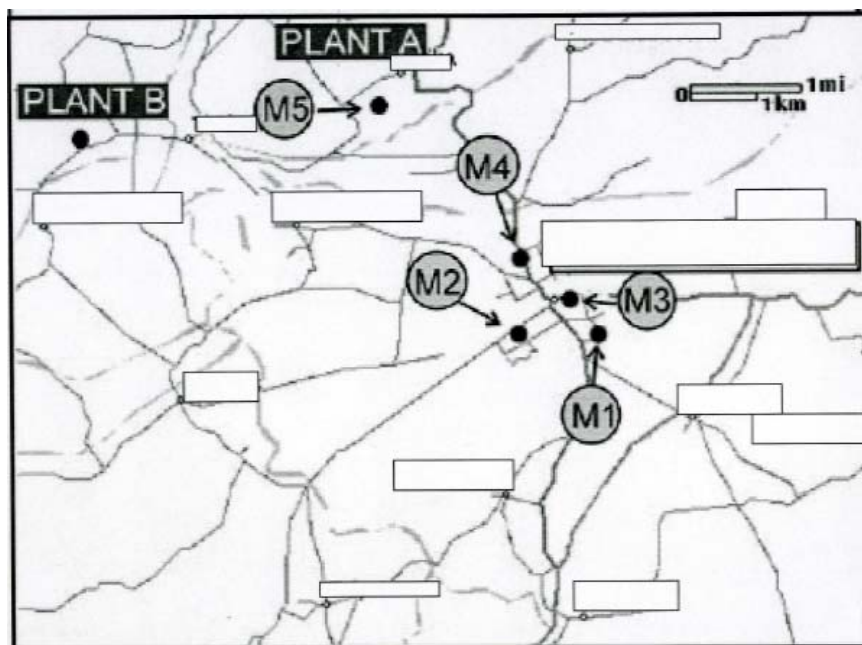

Fig. VII.1. Map of the LPPII location. The bulk deposition sampling sites (M1-M5), as well the location of power plants A and B, are shown.

VII.1.2. Dust deposition

The results for the bulk deposition of particulate matter (g m^{-2}) from all the sampling in the nearest city (M1–M5) are presented in Table VII.1 and Table VII.2. The amount of dust deposition for the individual monthly sampling periods was highly variable. This is attributed to weather conditions that strongly affect the dispersion and deposition of air dust, as well to the fluctuation of emission sources over the seasons.

Table VII.1. Monthly values of dust load (g m^{-2}) in fallout samples from the nearest city (M1, M2, M3, M4, M5) sampling sites during February 1997 to January 1998.

Date	Sampling Site				
	M1	M2	M3	M4	M5
2/97	11.4	10.9	11.1	9.3	9.6
3/97	7.8	7.6	4.4	7.6	12.7
4/97	11.8	12.3	15.9	14.4	35.1
5/97	5.9	5.9	5.9	7.6	18.3
6/97	11.5	11.3	20.9	18.4	19.6
7/97	10.1	16.4	19.3	31.6	15.7
8/97	4.6	5.8	4.0	8.5	12.3
9/97	11.1	8.9	12.7	8.1	19.8
10/97	4.4	3.9	5.4	5.7	25.4
11/97	8.6	7.0	12.7	8.0	32.4
12/97	4.4	4.9	6.0	7.8	13.2
1/98	6.3	6.5	7.9	7.9	16.5

The estimated error does not exceed 2%.

Table VII.2. Seasonal variations of all the measured parameters in the nearest city fallout samples (GMGGSD).

Season	Dust Deposition (g m^{-2})				
	M1	M2	M3	M4	M5
Spring	8.2 ± 0.3	8.2 ± 0.4	7.4 ± 0.7	9.4 ± 0.4	20.1 ± 0.5
Summer	8.1 ± 0.5	10.2 ± 0.5	11.7 ± 0.9	10.0 ± 0.7	15.6 ± 15.6
Autumn	7.5 ± 0.5	6.2 ± 0.5	9.5 ± 0.9	7.2 ± 0.7	25.4 ± 25.4
Winter	6.8 ± 0.5	7.0 ± 0.4	8.1 ± 0.5	8.3 ± 0.2	12.8 ± 12.8

VII.1.3. Meteorological data

Meteorological data for the LPP II region are shown in Table VII.3. The data were obtained from the meteorological station of the Public Power Corporation, which is located between the power plant A and the nearest city at a distance of 1.5–2 km from the plant.

Table VII.3. Meteorological data concerning the sampling sites in the nearest city.

Month	Mean Velocity (m s^{-1})	Prevailing wind direction	Precipitation Height (mm)
2/97	1.6	NW	14
3/97	2.1	E	71
4/97	2.2	NW	70
5/97	1.8	NW	27
6/97	1.8	NW	7
7/97	2.3	NW	9
8/97	2.1	NW	49
9/97	1.6	ESE	22
10/97	1.6	E	109
11/97	1.4	SE	150
12/97	1.6	ESE	247
1/98	1.4	ESE	59

VII.1.4. Sample collection

Bulk (wet + dry) atmospheric deposition samples were collected, on a monthly basis, at five sites (M1–M5) (see Figure Vii.1). Four of the sampling sites (M1–M4) were located in the city, at different distances from the power plant A (M4, M3, M2, M1 in increasing distance), while M5 was located in the area of power plant A and specifically on the roof of the Administration Building.

The sampling campaign was performed simultaneously at the two cities and lasted from February 1, 1997 to January 31, 1998. The samples were collected in high walled plastic (PVC) pots with 32.5 cm opening in diameter, which were located on the flat roof of two-story buildings. The pot was placed in an open area on the first of the month and left for 1 month. The results are summarized on a seasonal basis in Table VII.4.

Unfortunately the concentration of the naturally occurring radionuclides (^{238}U and ^{232}Th) was determined by Instrumental Neutron Activation Analysis (INAA), so there are no data concerning the ^{226}Ra concentration. But based on many measurements performed by the reporting laboratory in fly ash samples, the ratio of $^{238}\text{U}/^{226}\text{Ra}$ is almost equal to 1.

Table VII.4. Seasonal variations of all the measured parameters in fallout samples (GMGGSD).

Season	^{238}U activity (Bq m^{-2})				
	M1	M2	M3	M4	M5
Spring	2.89 ± 0.43	3.34 ± 0.36	3.63 ± 0.46	3.64 ± 0.19	11.02 ± 0.60
Summer	3.05 ± 0.81	3.16 ± 0.63	2.36 ± 1.21	4.16 ± 0.68	10.88 ± 0.26
Autumn	2.65 ± 0.45	2.82 ± 0.17	4.19 ± 0.48	2.77 ± 0.36	19.2 ± 0.43
Winter	3.40 ± 0.22	4.18 ± 0.22	4.55 ± 0.16	5.09 ± 0.24	9.38 ± 0.46
Season	^{232}Th activity (Bq m^{-2})				
	M1	M2	M3	M4	M5
Spring	0.25 ± 0.47	0.27 ± 0.45	0.19 ± 0.46	0.34 ± 0.37	0.66 ± 0.57
Summer	0.24 ± 0.69	0.32 ± 0.62	0.36 ± 1.12	0.63 ± 0.66	0.50 ± 0.21
Autumn	0.24 ± 0.57	0.26 ± 0.38	0.36 ± 0.61	0.27 ± 0.47	1.20 ± 0.48
Winter	0.24 ± 0.74	0.29 ± 0.72	0.32 ± 0.86	0.31 ± 0.88	0.54 ± 0.56

Following systematic samplings over a period of 12 years at the LPP II plants A and B, it was well established that the ^{226}Ra content of the lignite feeding the plant and the ashes produced are not statistically different in the two plants examined. The ^{226}Ra concentration of the lignite, the fly ash and the slag at the B plant was found equal to 348 ± 29 , 905 ± 78 and $662 \pm 62 \text{ Bq kg}^{-1}$ dry material, respectively.

In the case of certain fly ash samples, it was found that they were highly enriched in ^{210}Pb , with the ratio $^{210}\text{Pb}/^{226}\text{Ra}$ reaching the value of 4, depending on the sampling location along the emission control system of the LPP II-B power plant.

Given the ^{226}Ra content of the lignite, the ash content, the partitioning between slag and fly ash and the efficiency of the emission control devices, the ^{226}Ra radioactivity discharges from plant B are estimated to about $3500 \text{ MBq (Gwa)}^{-1}$ which is much lower than those of plant A $50000 \text{ MBq (Gwa)}^{-1}$

This is attributed to the high difference in the efficiency of the electrostatic precipitation devices in the two plants.

VII.1.5. Dietary Consumption

Assume default parameters for the consumption. Also assume that the inhabitants mainly consume locally produced products. The measured uranium concentration in water was 0.05 – 0.28 mg L⁻¹ (very low).

VII.1.6. Further information

The wind in the studied area is from a sector between NW and E, with a mean velocity ranging from 1.4 to 2.3 m s⁻¹. The north westerly flows in the region favour transport of pollutants emitted from the plant A and plant B located to the NW of the city. Considering the results the highest values in all measured parameters concerning the city are recorded in summer (June–July) in site M4, which is closer to plant A. The prevailing wind direction during this season is NW. However, statistical analysis does not show a seasonal effect on any of the measured parameters in the four sampling sites in the city (M1-M4).

It has been shown [66] that the concentrations of ²²⁶Ra in surface soil samples around the area of power plant A present higher values within a distance of 0–5 km from the power plant.

The city is located in this area of maximum deposition. Fly ash particles have been deposited on the roads and surface soil in and around the city after 30 years of power plant A operation. There are also open fly ash deposits around the power plants. Consequently, winds from any direction also transfer particulate matter enriched in radionuclides in the atmosphere of the city. This fact makes the contribution of the NW flows not apparent in the results presented here.

Moreover, in addition to determining the direction and speed at which particulate matter travel, other conditions might also affect the behaviour and transport of the individual particles in the atmosphere [67].

An approximate estimate of the dispersed fly ash activity concentration can be calculated using the equation [68]:

$$A_f = A_a x + A_s (1 - x) \quad (\text{VII.1})$$

where x is the contribution of the fly ash dispersion, and A_f, A_a and A_s the activities of ²³⁸U or ²³²Th in the dust, fly ash and surface soil, respectively. It is assumed that the total fallout in the city consists only of escaping fly ash and resuspended surface soil. The mean ²³⁸U concentrations in fallout and fly ash samples in the city were found to be 37 and 78 mg kg⁻¹, while for ²³²Th they were 8.7 and 13.7 mg kg⁻¹, respectively. The corresponding specific activity values for uranium are 460 and 967 Bq kg⁻¹ and for thorium 35 and 55 Bq kg⁻¹ respectively.

The A_s value was taken from reference [66], assuming that an equilibrium exists between ²³⁸U and ²²⁶Ra. Based on the above values, it is estimated that about 30% of the ²³⁸U-activity and 20% of the ²³²Th-activity in fallout samples is attributed to the dispersion of fly ash from the power plant. According to these results, the activity concentrations of ²³⁸U and ²³²Th in surface soil were found to be 320 and 28 Bq kg⁻¹, respectively. These values are in the range of (26–337) Bq kg⁻¹ ²²⁶Ra and (24–41) Bq kg⁻¹ ²³²Th for surface soil within a distance of 0–5 km from the power plant A given in reference [66].

(The enhanced values of natural radioactivity in fallout samples from the city are attributed to resuspension of the enriched radionuclides in surface soil (mainly in ^{238}U) by the meteorological conditions, traffic and anthropogenic activities and to transport of fly ash particles, escaping from the stacks of the lignite power plants located to the north-west of the city).

VII.2. Phosphogypsum stack scenario (PGDS1)

VII.2.1. Basic figures and tables for PGDS1

The layout of the PGDS1 site is shown in Figure VII.3. There are six phosphogypsum stacks, and a large number of surface water and groundwater sampling points. There is a lake to the north and east of the stacks, and sea to the south. The phosphogypsum has “overflowed” from at least one stack into the lake and deposited as sediment.



Fig. VII.2. A map of the PGDS1 site, taken from Google.

Figure VII.3 shows the layout of the phosphogypsum stacks (area and thickness), and the surface water and groundwater sampling points. The area where phosphogypsum has deposited as lake sediment is bounded to the south and west by stacks 4, 5 and 6.

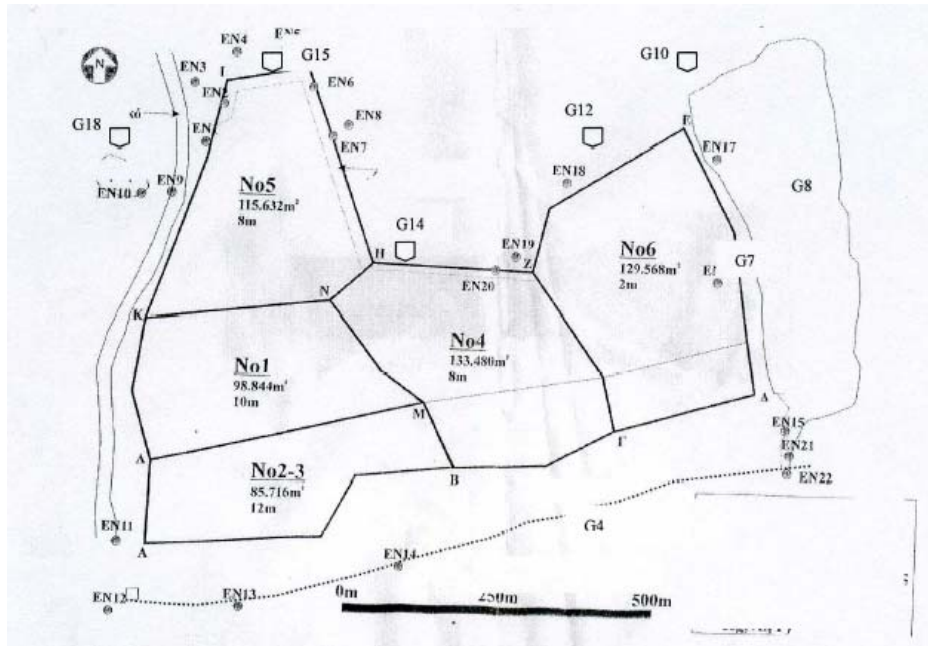

Fig. VII.3. Layout of the PGDS1 site, showing the of the phosphogypsum stacks (No. 1-6), the locations of the surface water sampling points (EN), and the locations of the ground water sampling sites (G). G13 is not shown on the map but is north of G15.

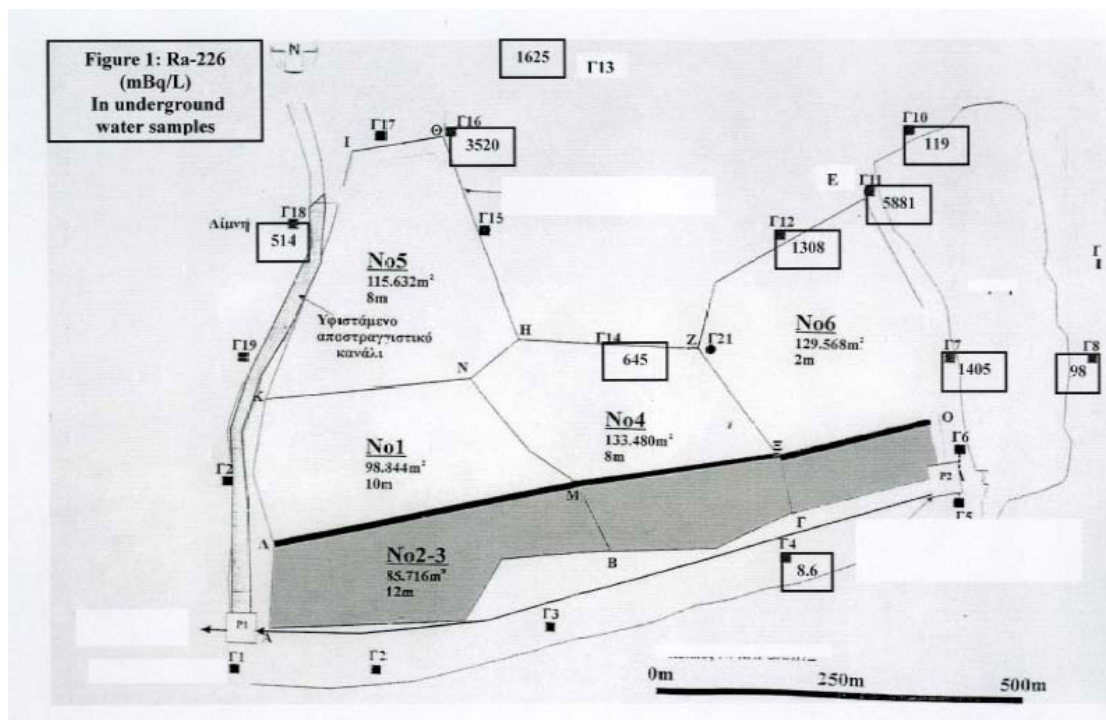

Fig. VII.4. Distribution of the ²²⁶Ra concentrations in groundwater.

Table VII.5 gives the results of measurements of ^{238}U and ^{226}Ra in surface water and groundwater (first sampling). Table VII.6 gives the results of measurements of ^{238}U and ^{226}Ra in ground water (second sampling).

Table VII.5. Measured uranium and radium in surface water and groundwater (first sampling).

Sample point	^{238}U (mBq/L)	^{234}U (mBq/L)	^{226}Ra (mBq/L)
Ground water			
G4	249 ± 55	274 ± 60	8.6 ± 1.5
G14	1060 ± 85	1028 ± 82	645 ± 130
G16	341 ± 17	347 ± 17	3520 ± 940
G7	405 ± 100	503 ± 114	1405 ± 170
G8	121 ± 19	119 ± 19	98 ± 11
G10	297 ± 41	305 ± 42	119 ± 10
G11	912 ± 100	945 ± 102	5880 ± 510
G12	280 ± 30	268 ± 28	1308 ± 105
G13	870 ± 140	1017 ± 170	1625 ± 260
G18	244 ± 20	237 ± 24	514 ± 32
Surface water			
EN1	2180 ± 190	2320 ± 200	134 ± 24
EN4	29 ± 8	35 ± 9	N.D.
EN6	426 ± 42	448 ± 44	N.D.
EN8	250 ± 20	251 ± 19	1110 ± 240
EN10	147 ± 10	143 ± 9	62 ± 14
EN11	1352 ± 81	1367 ± 82	23 ± 6
EN14	67 ± 8	73 ± 9	19 ± 2
EN17	22 ± 4	23 ± 4	178 ± 15
EN18	1037 ± 121	987 ± 115	72.6 ± 6.4
EN19	245 ± 43	280 ± 49	14.0 ± 2.8
EN22	26 ± 9	42 ± 11	15.1 ± 1.7

Table VII.6. Measured uranium and radium concentrations in ground water (second sampling).

Sample point	^{238}U (mBq/L)	^{234}U (mBq/L)	^{226}Ra (mBq/L)
G4	<2	<2	37 ± 4
G7	<4	<4	18.0 ± 1.6
G9	12 ± 10	17 ± 11	< 1
G10	<2	<2	29.0 ± 1.8
G11	5.8 ± 2.1	5.7 ± 2.0	38 ± 7
G12	930 ± 100	919 ± 104	15 ± 2
G13	80 ± 30	64 ± 22	138 ± 46
G14	570 ± 90	524 ± 79	13.2 ± 1.6
G16	220 ± 20	228 ± 24	57.3 ± 2.8
G18	80 ± 50	43 ± 35	87 ± 11

Table VII.7. Natural radionuclide concentration in phosphogypsum samples (Bq kg⁻¹).

Sample code	Description	²²⁶ Ra (185 keV)	²²⁶ Ra (progeny)	²¹⁰ Pb	²³⁴ Th
Soil samples from G1					
PG007120106	PGSI G1 N=1, 0-2.00m	230 ± 30	118 ± 15	110 ± 90	50 ± 7
PG001090306	PGSI G1 N=2 2.00 - 4.00m	204 ± 28	122 ± 13	51 ± 24	70 ± 12
PG003100306	G1 N=3 4.00-6.80m	53 ± 8	30 ± 3	22 ± 5	30 ± 4
PG001100306	G1 N=4 6.80 - 8.60m	13 ± 11	11 ± 2	< 22	17 ± 6
PG002100306	N=5 8.60-10.60m	34 ± 12	24 ± 4	< 21	30 ± 10
PG002090306	G1 N=6 10.60 - 12.1	72 ± 13	45 ± 5	< 50	36 ± 4
PG006120106	PGSI G1 12.10	77 ± 30	60 ± 11	< 98	70 ± 28
Phosphogypsum samples from basins No 2,3					
PG006070206	PGSI 1/2005	320 ± 50	280 ± 40	120 ± 40	25 ± 8
PG001180106	PGSI 2/2005	500 ± 70	370 ± 50	260 ± 50	33 ± 5
PG011070206	PGSI 3/2005	430 ± 70	320 ± 50	210 ± 50	33 ± 8
PG002180106	PGSI 4/2005	600 ± 100	490 ± 70	200 ± 60	40 ± 11
PG014070206	PGSI 5/2005	500 ± 60	440 ± 50	200 ± 50	14 ± 5
PG012070206	PGSI 6/2005	340 ± 30	255 ± 16	220 ± 40	84 ± 6
PG003070206	PGSI 7/2005	320 ± 40	320 ± 40	130 ± 40	46 ± 9
PG005070206	PGSI 8/2005	710 ± 50	550 ± 30	420 ± 60	15 ± 4
PG009070206	PGSI 9/2005	440 ± 60	315 ± 40	120 ± 60	21 ± 7
Phosphogypsum samples from basin No 4					
PG003090306	PGSI 10/2005	28 ± 7	16 ± 2	14 ± 5	7 ± 1
PG013070206	PGSI 11/2005	657 ± 91	453 ± 55	350 ± 70	58 ± 8
PG008070206	PGSI 12/2005	320 ± 50	250 ± 30	120 ± 60	37 ± 11
PG007070206	PGSI 13/2005	350 ± 60	300 ± 50	240 ± 60	45 ± 8
PG004070206	PGSI 14/2005	820 ± 100	580 ± 70	420 ± 80	41 ± 9
PG010070206	PGSI 15/2005	670 ± 120	470 ± 80	390 ± 110	51 ± 9
PG001070206	PGSI 16/2005	660 ± 90	450 ± 60	350 ± 70	58 ± 8
PG002070206	PGSI 17/2005	560 ± 50	391 ± 26	490 ± 100	12 ± 1
Fresh phosphogypsum samples					
PG002200208	PGSI 16/7 - 31/7	480 ± 60	420 ± 40	210 ± 60	40 ± 7
PG004200206	PGSI 16/8 - 31/8 -05	600 ± 70	560 ± 60	240 ± 80	29 ± 8
PG005200206	PGSI 1/8 - 15/8	380 ± 50	350 ± 40	120 ± 40	31 ± 8
PG003200205	PGSI 1/9- 15/9/2005	660 ± 90	600 ± 70	400 ± 80	25 ± 4
PG007120106	PGSI G1 N=1, 0-200M	50 ± 7	58 ± 7	67 ± 15	730 ± 130
PG001090306	PGSI G1 N=2 2.00 - 4.00m	70 ± 12	24 ± 3	30 ± 13	460 ± 50
PG003100306	G1 N=3 4.00-6.80m	30 ± 4	27 ± 3	33 ± 7	470 ± 70
PG001100306	G1 N=4 6.80 - 8.60m	17 ± 6	9 ± 2	12 ± 2	160 ± 20
PG002100306	N=5 8.60-10.60m	30 ± 10	21 ± 4	30 ± 11	350 ± 60
PG002090306	G1 N=6 10.60 - 12.1	36 ± 4	43 ± 4	61 ± 8	742 ± 100
PG006120106	PGSI G1 12.10	70 ± 28	60 ± 11	56 ± 11	850 ± 140
Phosphogypsum samples from basins No 2,3					
PG006070206	PGSI 1/2005	25 ± 8	7 ± 1	6 ± 1	18 ± 7
PG001180106	PGSI 2/2005	33 ± 5	9 ± 2	10 ± 7	11 ± 3
PG011070206	PGSI 3/2005	33 ± 8	9 ± 3	11 ± 4	< 6
PG002180106	PGSI 4/2005	40 ± 11	10 ± 2	9 ± 2	< 7
PG014070206	PGSI 5/2005	14 ± 5	4 ± 1	4 ± 1	< 5
PG012070206	PGSI 6/2005	87 ± 5	10 ± 1	11 ± 1	< 8
PG003070206	PGSI 7/2005	46 ± 9	9 ± 1	9 ± 1	< 5
PG005070206	PGSI 8/2005	15 ± 4	20 ± 2	22 ± 2	< 15
PG009070206	PGSI 9/2005	21 ± 7	3 ± 1	4 ± 1	< 5
Phosphogypsum samples from basin No 4					
PG003090306	PGSI 10/2005	7 ± 1	< 2	1 ± 0	6 ± 2
PG013070206	PGSI 11/2005	58 ± 8	5 ± 1	5 ± 1	< 11
PG008070206	PGSI 12/2005	37 ± 11	< 4	5 ± 1	< 11
PG007070206	PGSI 13/2005	45 ± 8	7 ± 2	9 ± 2	< 8
PG004070206	PGSI 14/2005	41 ± 9	10 ± 2	10 ± 1	< 10
PG010070206	PGSI 15/2005	51 ± 9	11 ± 2	10 ± 2	< 11
PG001070206	PGSI 16/2005	58 ± 8	5 ± 1	6 ± 1	< 9
PG002070206	PGSI 17/2005	12 ± 1	9 ± 1	11 ± 4	< 5
Fresh phosphogypsum samples					
PG002200208	PGSI 16/7 - 31/7	40 ± 7	25 ± 3	22 ± 2	< 5
PG004200206	PGSI 16/8 - 31/8 -05	29 ± 8	4 ± 2	4 ± 1	< 8
PG005200206	PGSI 1/8 - 15/8	31 ± 8	32 ± 4	17 ± 7	< 7
PG003200205	PGSI 1/9- 15/9/2005	25 ± 4	< 3	2 ± 1	< 9

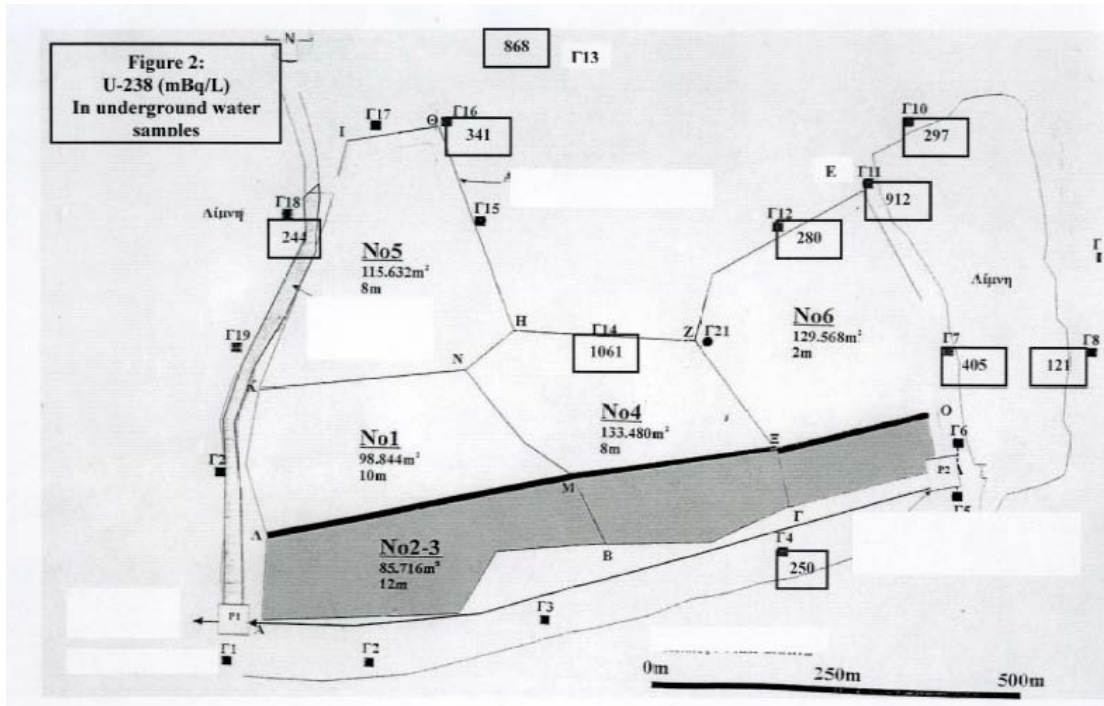

Fig. VII.5. Distribution of ^{238}U concentrations in groundwater.

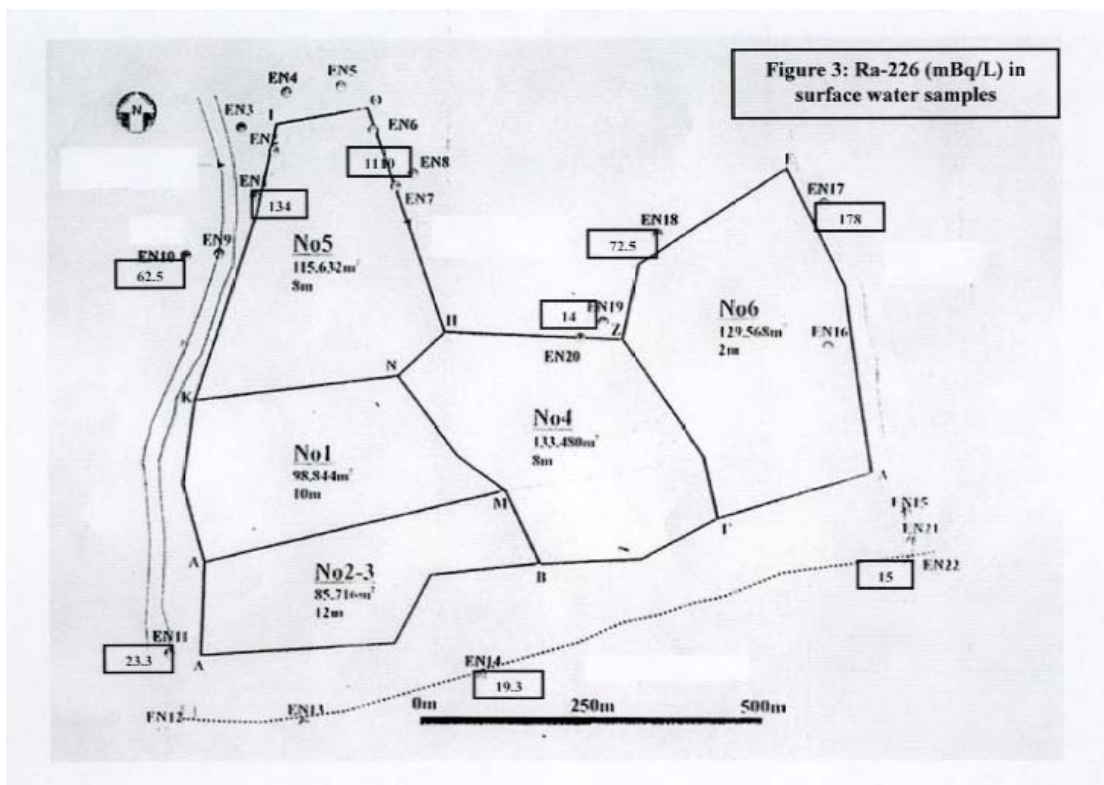

Fig. VII.6. Distribution of ^{226}Ra concentrations in surface water.

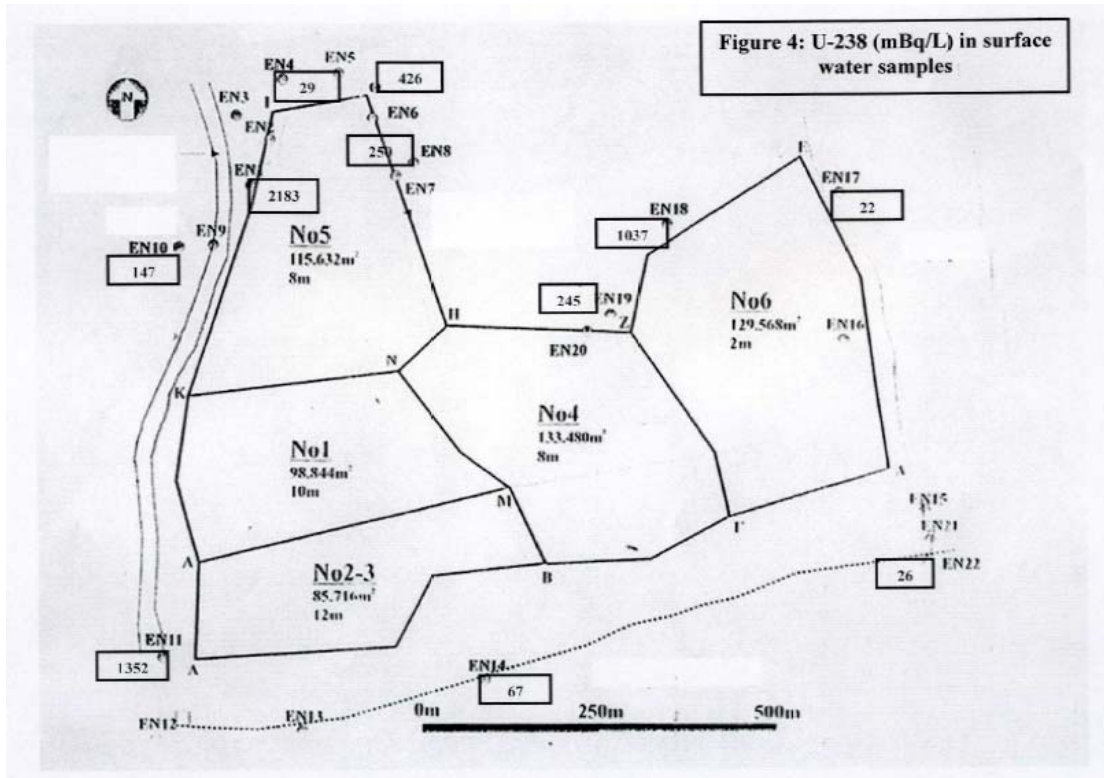

Fig. VII.7. Distribution of ²³⁸U concentrations in surface water.

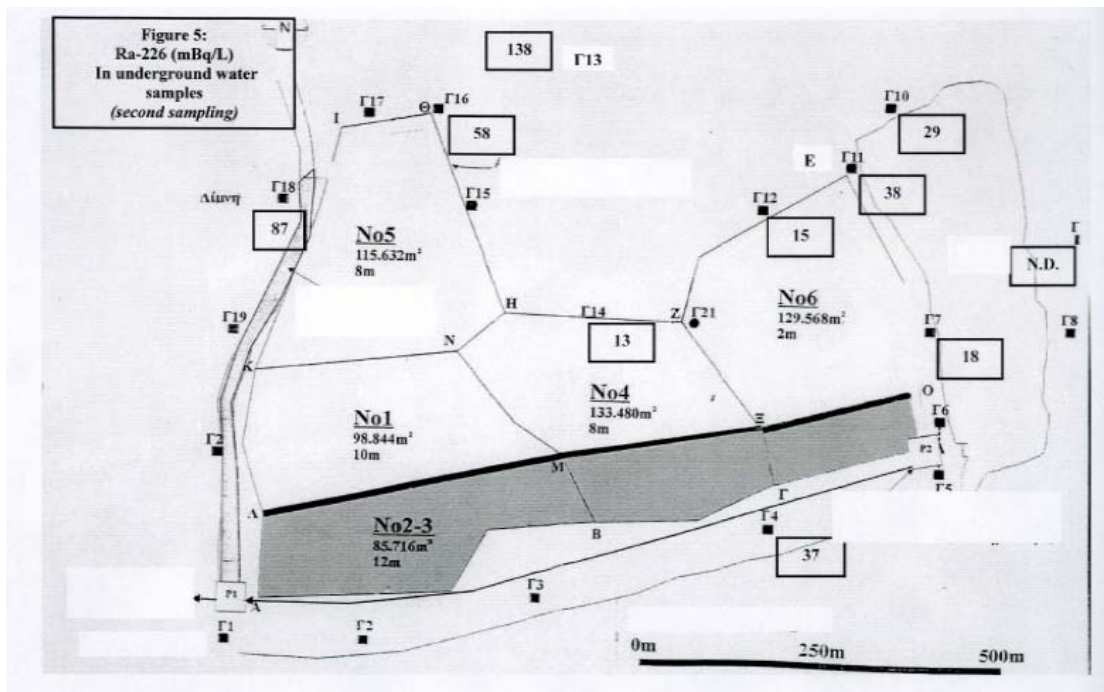

Fig. VII.8. Distribution of ²²⁶Ra concentrations in groundwater (second sampling).

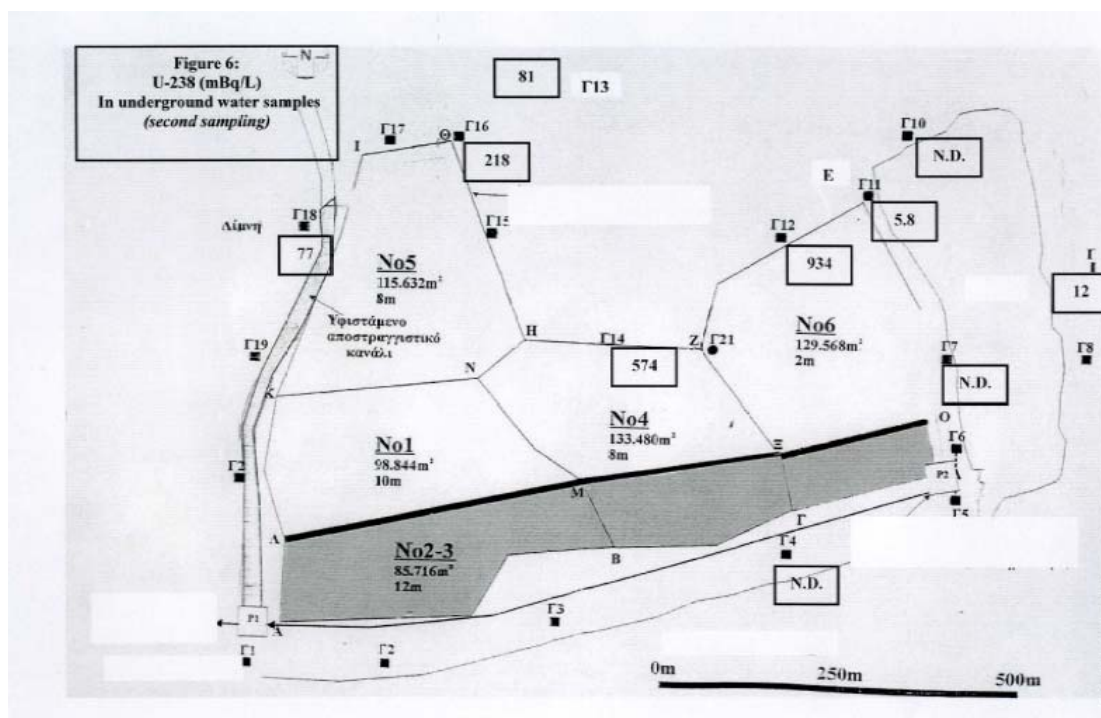

Fig. VII.9. Distribution of ^{238}U concentrations in groundwater (second sampling).

VII.3. Phosphogypsum stack scenario (PGDS2)

This site consists of a single phosphogypsum stack. The layout of the site and the locations of the sampling points are shown in Figure VII.10. The stack is surrounded by a concrete retaining wall.

Table VII.8. Measured concentrations of ^{234}U and ^{238}U in ground water and percolate for 2006 and 2007.

Sampling date	Sampling point	Sample kind	^{234}U	^{238}U	$^{234}\text{U}/^{238}\text{U}$
15/03/2006	PzE 01/05	groundwater	452 ± 40	316 ± 40	1.43 ± 0.22
30/01/2007	Pz E 01/05	groundwater	566 ± 70	385 ± 52	1.47 ± 0.27
15/03/2006	PzE 05/05	groundwater	1045 ± 119	908 ± 104	1.15 ± 0.19
30/01/2007	Pz E 05/05	groundwater	194 ± 28	179 ± 27	1.08 ± 0.23
15/03/2006	PzE 11/05	groundwater	—	—	—
30/01/2007	Pz E 11/05	groundwater	70 ± 16	49 ± 14	1.41 ± 0.52
15/03/2006	WELL#19	percolate	15560 ± 1710	14330 ± 1570	1.09 ± 0.17
30/01/2007	WELL#19	percolate	15428 ± 1693	14083 ± 1547	1.10 ± 0.17
30/01/2007	Pz E 01/05	groundwater	566 ± 70	385 ± 52	1.47 ± 0.27
30/01/2007	Pz E 02/05	groundwater	397 ± 50	326 ± 43	1.22 ± 0.22
30/01/2007	Pz E 05/05	groundwater	194 ± 28	179 ± 27	1.08 ± 0.23
30/01/2007	Pz E 11/05	groundwater	70 ± 16	49 ± 14	1.41 ± 0.52
30/01/2007	WELL#19	percolate	15428 ± 1693	14083 ± 1547	1.10 ± 0.17

Table VII.8 gives measured concentrations of ^{234}U and ^{238}U in ground water and percolate at specified sampling points. Table VII.9 gives measured concentrations of individual radionuclides in phosphogypsum and phosphorites.

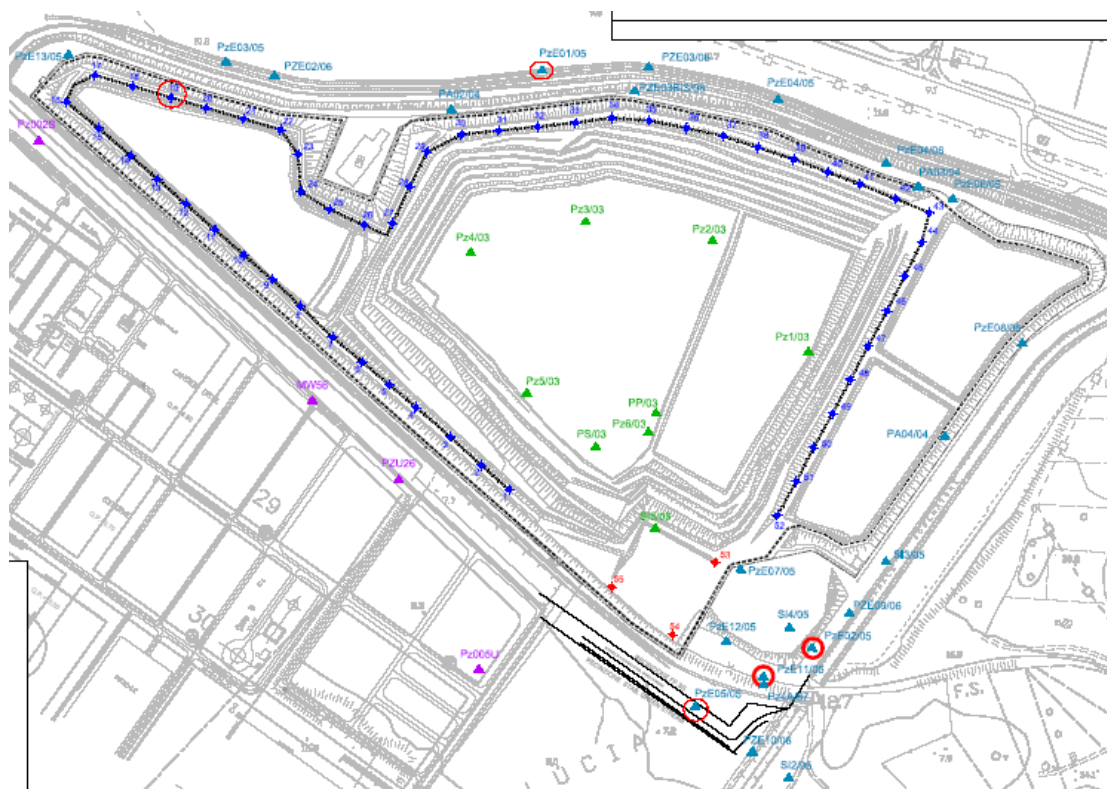

Fig. VII.10. Layout of the site, and locations of the sampling points (shown in colour). The labelling of the sampling points corresponds to Table VII.8 and Table VII.9.

Summary of available data:

- (1) the stack is positioned in an area where a bed of clay (hydraulic conductivity $\sim 10\text{-}12 \times 10^{-11} \text{ m s}^{-1}$, thickness = 20-30 m, depth = 7-21 m) is present; the clay bed extends for hundreds of hectares; the hydraulic conductivity of phosphogypsum is $5 \times 10^{-6} \text{ m s}^{-1}$;
- (2) the clay bed and the surrounding concrete retaining wall, inserted in the clay bed for 2-3 meters, should form a barrier for the superficial (i.e. over the clay bed) groundwater normally flowing from NW to SE; no investigation exists on presence of groundwater below the clay bed;
- (3) the superficial groundwater is not permanent, i.e. it completely depends on rainfalls, which is very rare but intense; for long periods in a year piezometers and wells, outside the N-NW side of the stack are dry; therefore groundwater samples are not collected on a regular basis;
- (4) in the SE corner outside the stack wall, where the sampling points Pz 02/05 and Pz 11/05 are, a lens of sand receives water from the superficial groundwater getting around the stack and from the surrounding hills; for this area information needed to model the dispersion of NORM is available:
 - (a) hydraulic conductivity: $2 \times 10^{-4} \text{ m s}^{-1}$
 - (b) Darcy velocity: 5 m a^{-1}
 - (c) the depth of water is 6.25 m in Pz 11/05 which is at 12.30 m above sea level; the depth of water is 4 m in Pz 02/05, which is at 10.4 m above sea level

From these hydrogeological data, leaching of NORM from the phosphogypsum stack should not be possible. Radionuclides now measured at sampling points near the SE corner could be the result of contamination which occurred before the containing wall was constructed.

Table VII.9. Measured concentrations of radionuclides in phosphogypsum and phosphorites.

PHOSPHOGYPSUM		Nuclide	Bq kg⁻¹
<i>High Purity Germanium 38% spectrometer</i>		²²⁶ Ra	418 ± 27
		²¹⁴ Pb	313 ± 15
		²¹⁴ Bi	272 ± 12
		²¹² Pb	19 ± 1
		²¹² Bi	19 ± 2
		^{234m} Pa	25 ± 4
<i>High Purity Germanium 94% spectrometer</i>		²²⁶ Ra	410 ± 35
		²¹⁴ Pb	293 ± 27
		²¹⁴ Bi	248 ± 18
		²¹² Pb	18 ± 1
		²¹² Bi	19 ± 2
		^{234m} Pa	<10
PHOSPHORITES		Nuclide	Bq kg⁻¹
<i>High Purity Germanium 38% spectrometer</i>		²²⁶ Ra	1249
		²¹⁴ Pb	1261
		²¹⁴ Bi	1170
		²¹² Pb	40
		²¹² Bi	41
		²³⁵ U	65
<i>High Purity Germanium 94% spectrometer</i>		^{234m} Pa	1415
		²²⁶ Ra	1237
		²¹⁴ Pb	1230
		²¹⁴ Bi	1093
		²¹² Pb	39
		²¹² Bi	40
	²³⁵ U	66	
	^{234m} Pa	1459	

APPENDIX VIII. TESTING OF REAL SCENARIOS

VIII.1. Power Plant Scenario – LPPII

Three models (PC-CREAM, COMPLY and CROM) were used for this work.

VIII.1.1. LPPII scenario summarised

There are two power plants (A and B), and five sampling sites (M1 to M5). Power plant B is 3 km due west of Plant A.

The descriptions below are based on the prompts within the ‘Assessment Details’; ‘Atmospheric’ within ASSESSOR. In ASSESSOR, Stack 1 = Plant A, is described as distance zero, bearing zero. Stack 2 = Plant B, is described as distance 3000 metres and bearing 270 degrees.

Integration time: 50 years for an adult.

Discharge data: could not introduce ^{232}Th nuclide to ASSESSOR nuclide suite, therefore progressed with ^{226}Ra and ^{238}U .

Discharge data:

Discharges of ^{226}Ra and ^{238}U (assuming ratio of 1:1) from:

Plant A $50,000 \text{ MBq a}^{-1} = 5 \times 10^{10} \text{ Bq a}^{-1}$.
Plant B $3,500 \text{ MBq a}^{-1} = 3.5 \times 10^9 \text{ Bq a}^{-1}$.

VIII.1.2. PC-CREAM calculations

Exposure pathways: all consumption pathways were used, and all external/inhalation pathways were used except for those concerned with beta doses.

Receptor bearings and distances: these are shown in Table VIII.1.

Table VIII.1. The distances and bearings of the sampling points.

Sampling point	Distance from unit A (km)	Bearing from unit A (degrees)
M1	3,800	135
M2	2,800	157
M3	3,100	135
M4	2,300	135
M5	300 (minimum value accepted)	0

(This was the only opportunity to put in receptor points. It is assumed that ASSESSOR calculates the receptor positions relative to Stack 2/Plant B since the Plant B bearing relative to Plant A is given earlier in the ASSESSOR prompt sheets.)

Meteorological Data: the data supplied in the scenario description is not suitable for use in PC-CREAM. Therefore the UNI50D.MET default file from PC-CREAM was used, together with the Pasquill/Smith scheme of stability factors.

Ingestion rates: these were all set to average values, except for cow’s milk and grain which were set at ‘critical’ values.

Occupancy/Inhalation rates: these were set to the PC-CREAM default values.

PC-CREAM requires a site name to be entered. In this case ‘Almarez’ (an inland site) was used. The ‘Almarez’ label in the in the pie-chart print-outs should be ignored.

Receptor deposition rates (Bq m^{-2}) for ^{238}U and ^{232}Th were extracted from the relevant plist100.ps! file. (it was found that ^{232}Th could be incorporated into the PLUME files but could not be included in the ASSESSOR runs). This file provided deposition rates in $\text{Bq m}^{-2} \text{ s}^{-1}$. By multiplying these values by the number of seconds in a year ($86,400 \times 365.25$), the s^{-1} term is removed leaving values in Bq m^{-2} .

Table VIII.2. Predicted and reported deposition rates.

	PC CREAM		Measured	
	^{238}U (Bq m^{-2})	^{232}Th (Bq m^{-2})	^{238}U (Bq m^{-2})	^{232}Th (Bq m^{-2})
Plant A	2.5 – 4.1	0.12 – 0.19		
Plant B	1.5 – 2.8	0.07 – 0.14		
Total	4.0 – 6.9	0.19 – 0.33	2.36 – 11.02	0.19 – 1.20

The results presented in Table VIII.2 show that there is extremely good agreement between the measured data and the predicted values from PC-CREAM.

Assumptions were made regarding the consumption rates and occupancy times/inhalation rates of the critical group. Calculated doses from the ‘Sum of stacks’ run show that the total dose over the first year is between 2.8 and 4.3 mSv and integrated over a 50 year period is between 3.6 and 5.5 mSv. Most of this dose is calculated to be delivered through inhalation of the two radionuclides considered here.

The nuclide and pathway breakdown pie charts for the 50 year integration period are included below.

Other information regarding the contribution from the individual stacks are available. This can be forwarded if required.

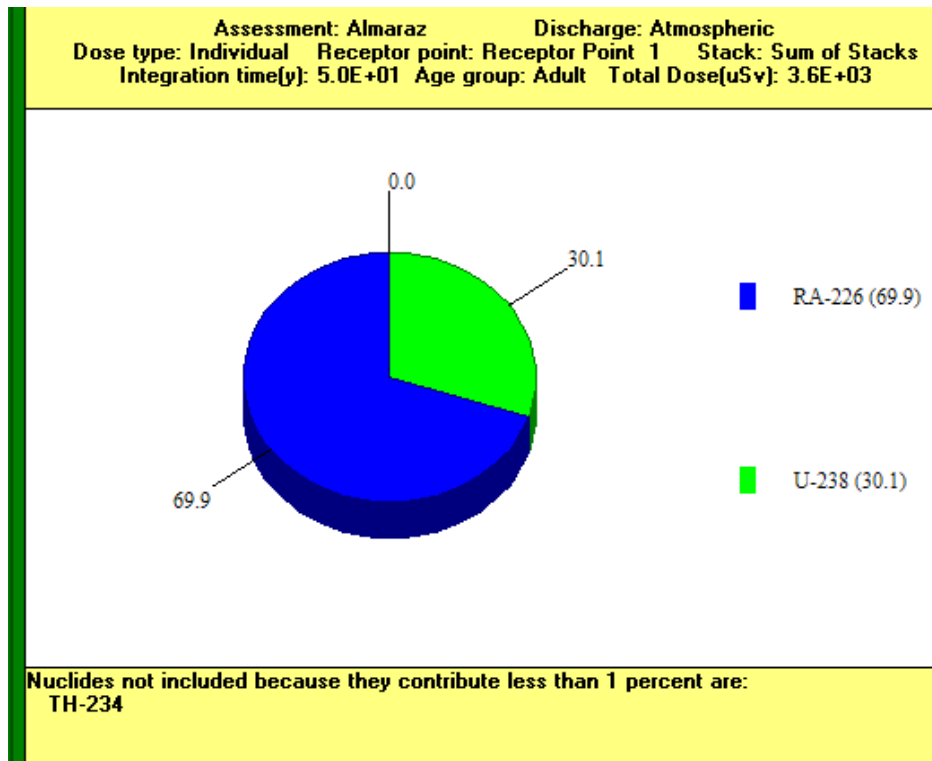

Fig. VIII.1. Calculated ^{226}Ra and ^{238}U concentrations at receptor point M1.

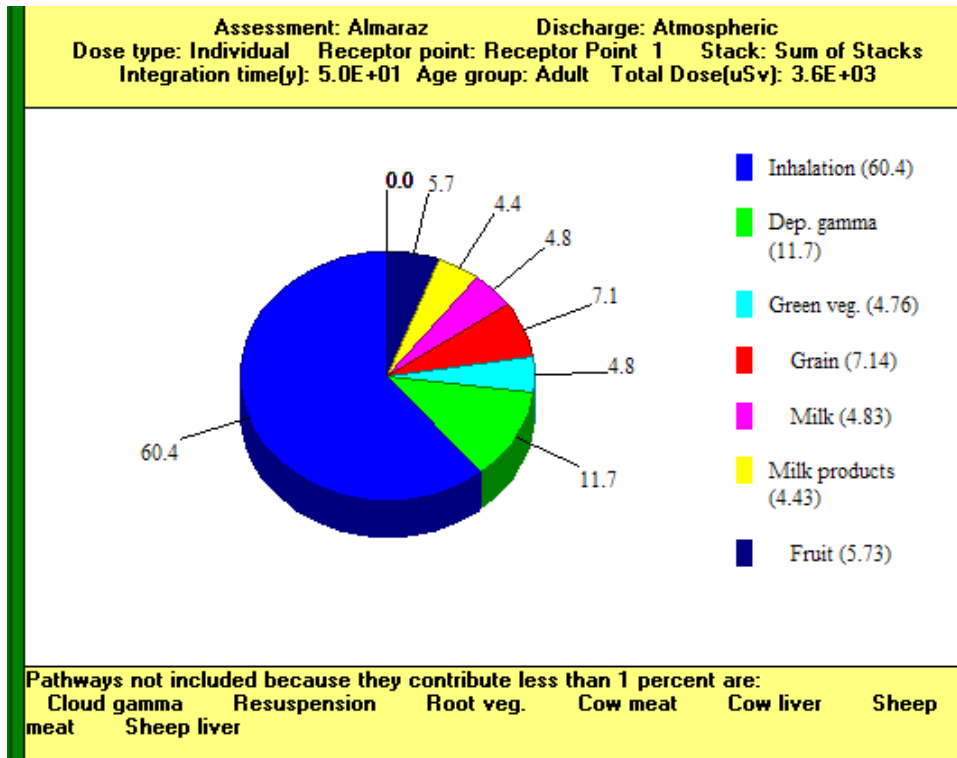

Fig. VIII.2. Calculated doses for different pathways at receptor point M1.

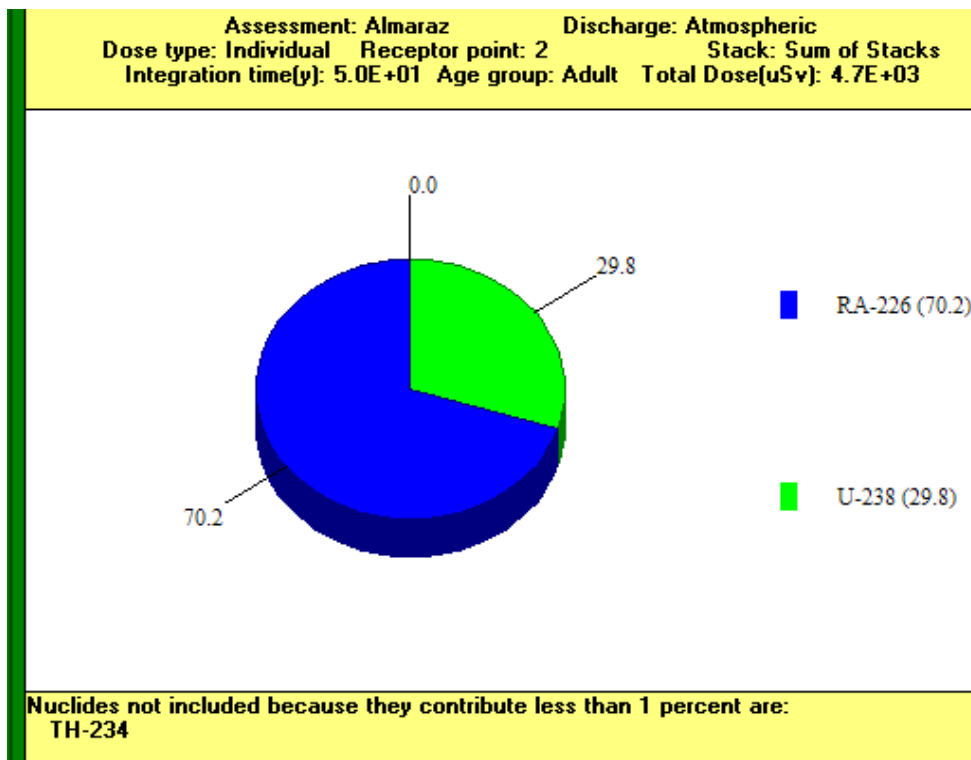

Fig. VIII.3. Calculated ^{226}Ra and ^{238}U concentrations at receptor point M2.

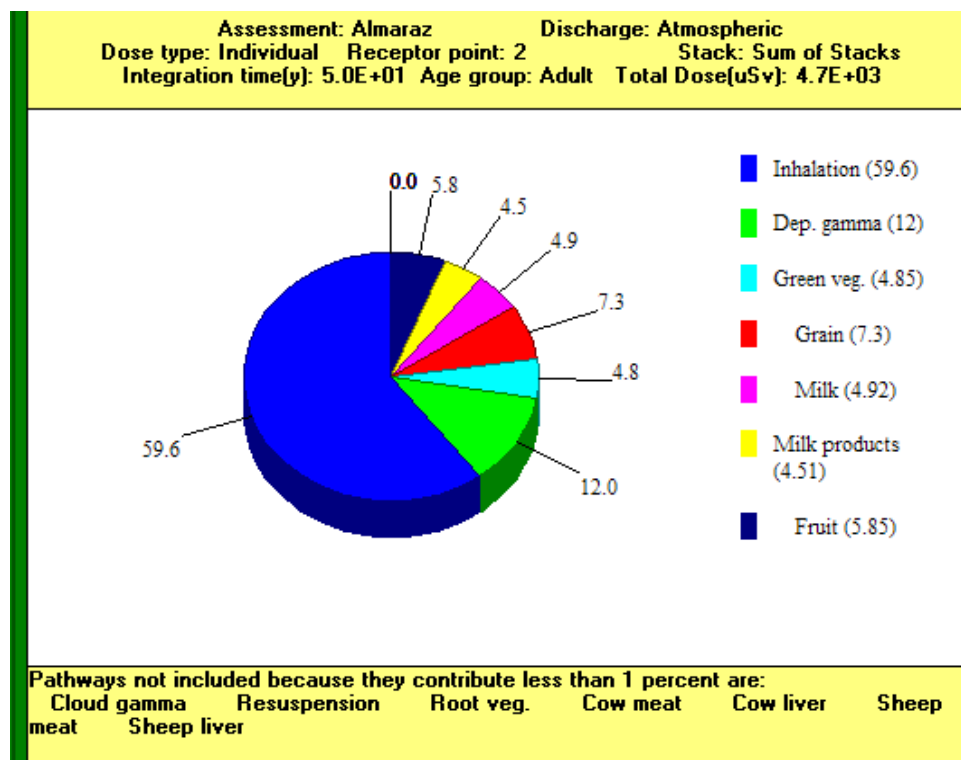

Fig. VIII.4. Calculated doses for different pathways at receptor point M2.

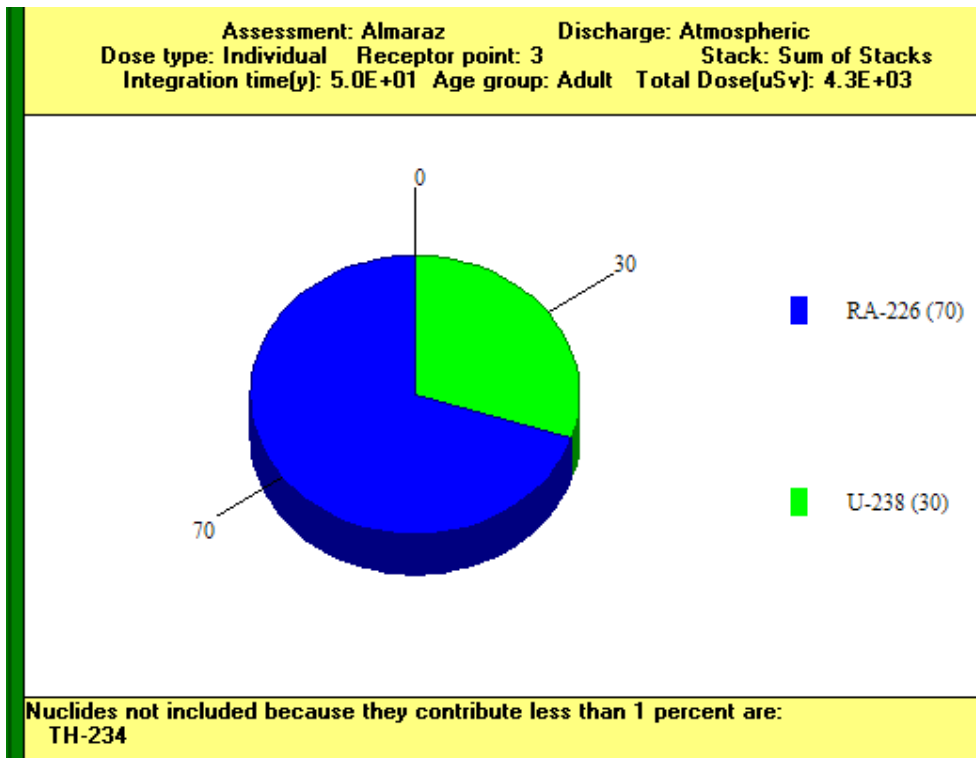

Fig. VIII.5. Calculated ^{226}Ra and ^{238}U concentrations at receptor point M3.

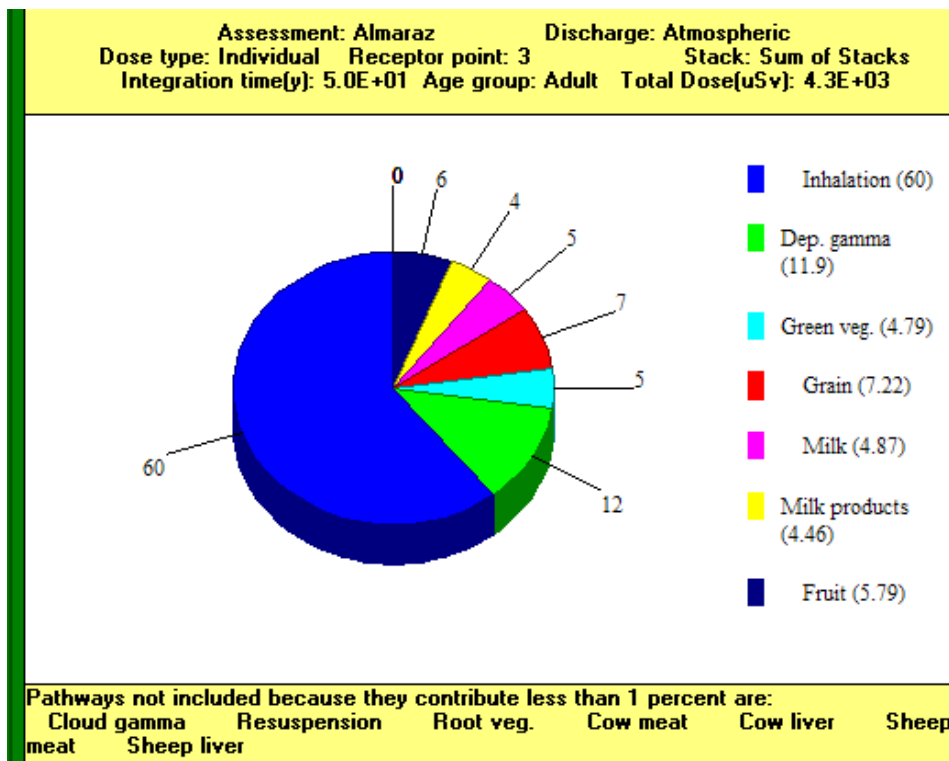

Fig. VIII.6. Calculated doses for different pathways at receptor point M3.

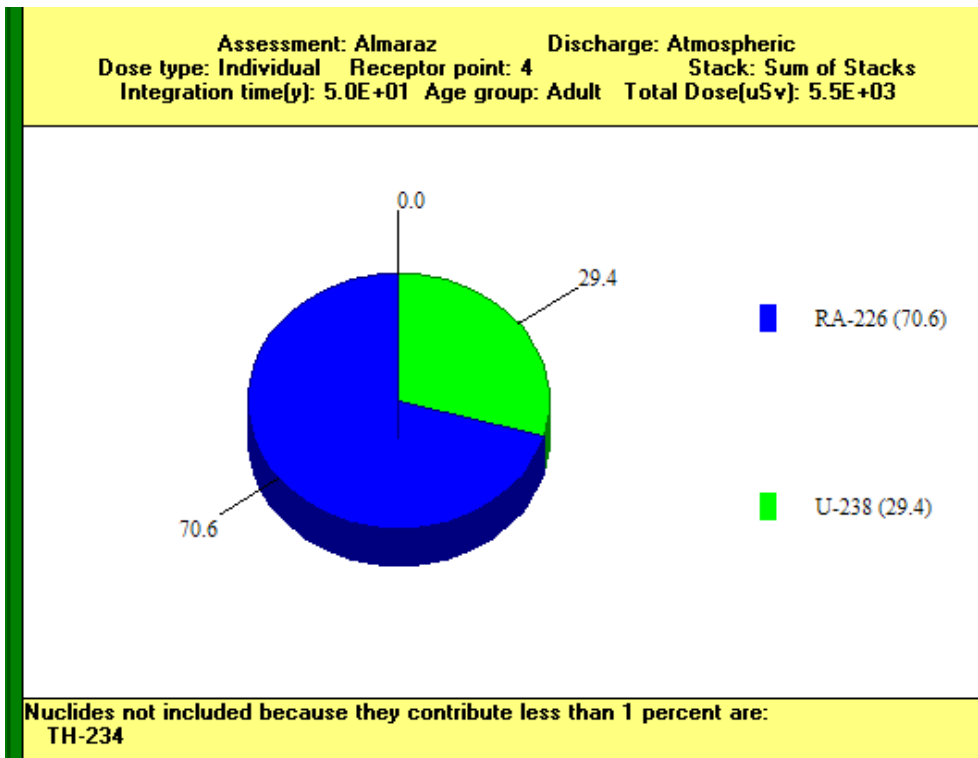

Fig. VIII.7. Calculated ^{226}Ra and ^{238}U concentrations at receptor point M4.

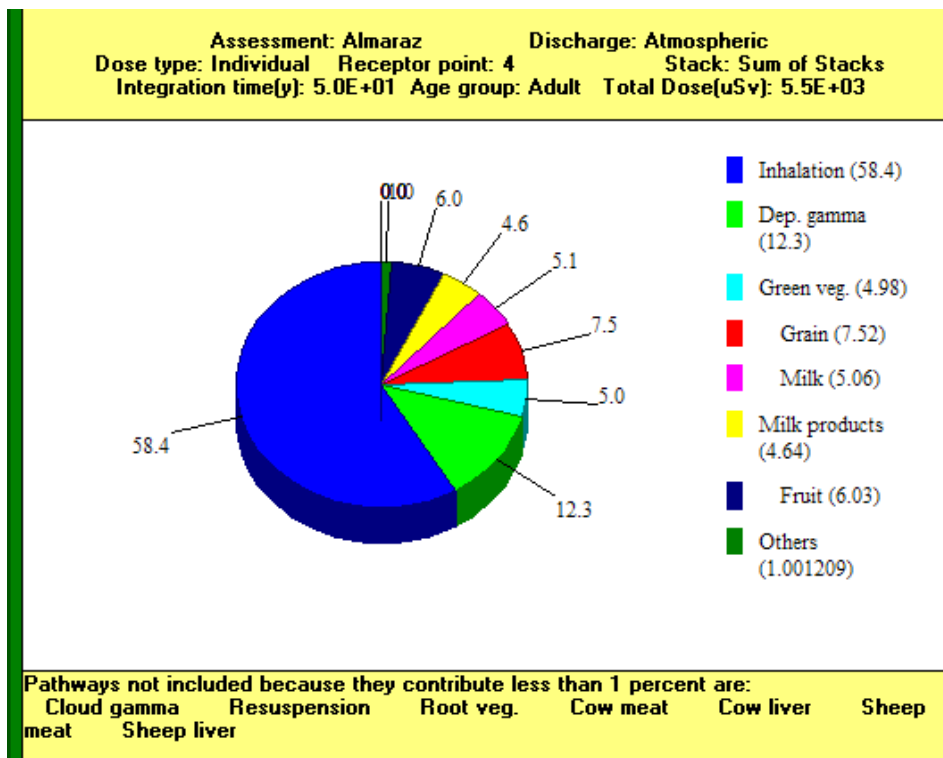

Fig. VIII.8. Calculated doses for different pathways at receptor point M4.

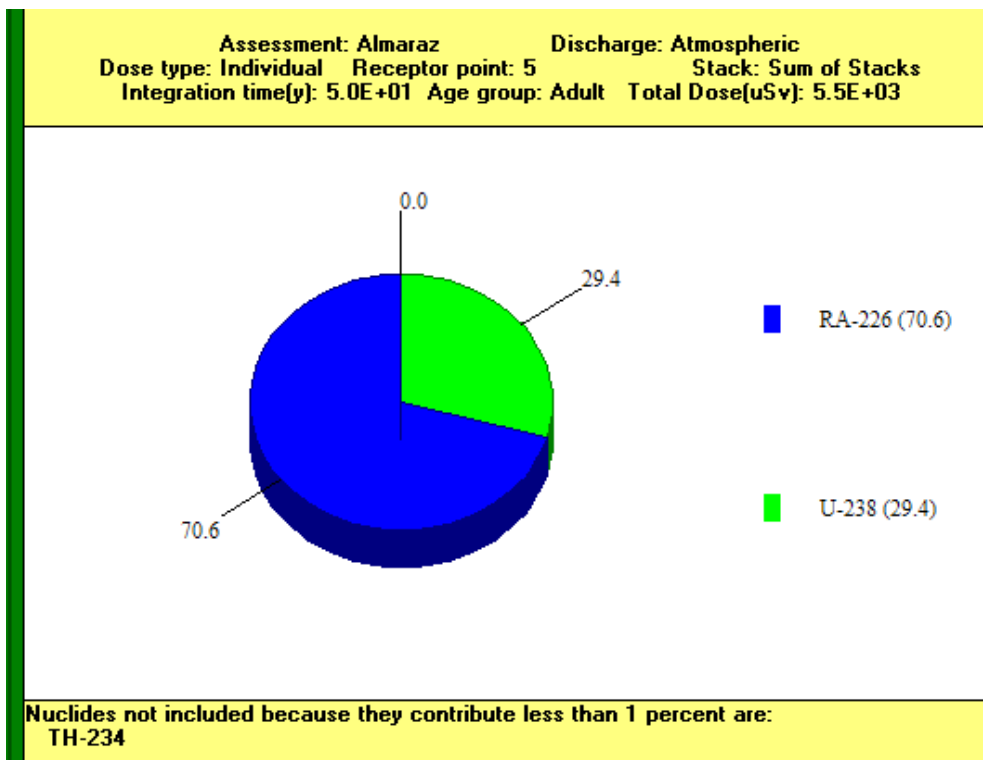

Fig. VIII.9. Calculated ^{226}Ra and ^{238}U concentrations at receptor point M5.

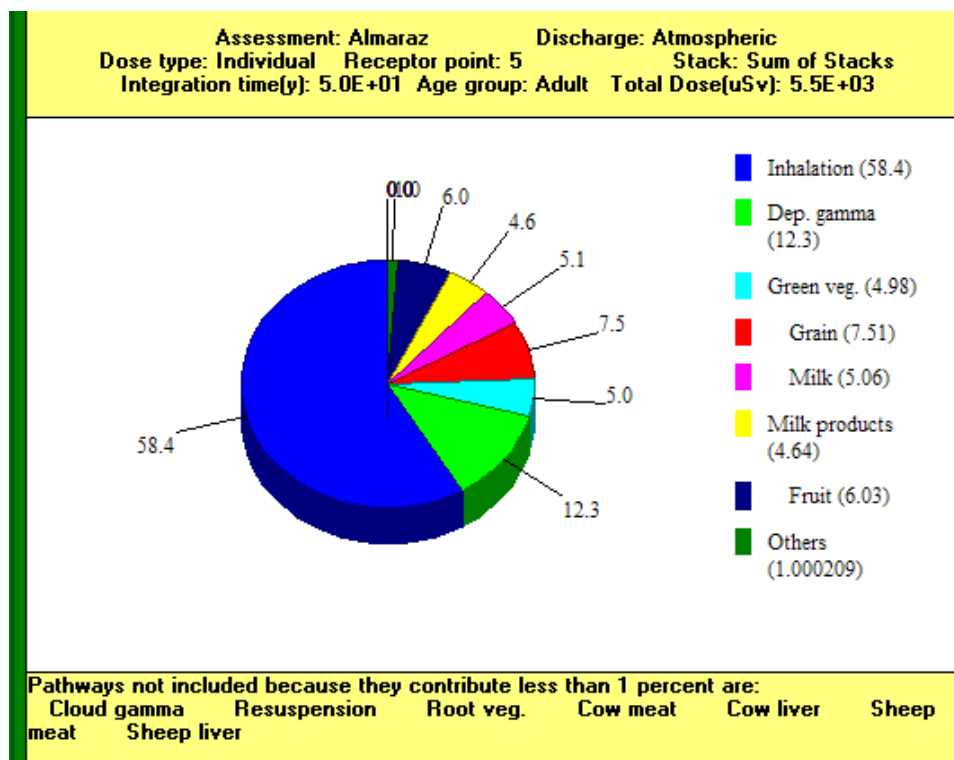

Fig. VIII.10. Calculated doses for different pathways at receptor point M5.

VIII.1.3. COMPLY calculations

The scenario description is given in Appendix VII.7. In the source term specification, the air discharge rate is not given.

Using the specified power production figures, the discharge rates for ^{226}Ra for Plant A ($5.0 \times 10^{10} \text{ Bq (GWa)}^{-1}$) and Plant B ($3.5 \times 10^9 \text{ Bq (GWa)}^{-1}$) were estimated to be $2.8 \times 10^{10} \text{ Bq a}^{-1}$ and $1.1 \times 10^9 \text{ Bq a}^{-1}$ respectively.

The available meteorological data are shown in Appendix VII.1.3. The data do not include wind rose data and atmospheric stability data. Also there are no data on local food production and consumption rates.

Therefore it is assumed that all meat, milk and plant food consumed by a local resident is produced locally. The assumed contaminated fraction of food is therefore 1.0. Consumption rates have been set to the default values used in COMPLY.

The COMPLY code was chosen because of its minimal data requirements, and because the data supplied for the scenario were not complete. COMPLY is a computerized screening tool for evaluating radiation exposure from atmospheric releases of radionuclides. The COMPLY code calculates the effective dose from radionuclides released from one or more stacks, and includes 4 levels of complexity (see Appendix II.1.1).

The dose estimated by this code is primarily intended for comparison with environmental standards but in the case in question it could be used for an upper dose level calculation. Atmospheric concentrations are estimated using a Gaussian plume model. The code calculates radionuclide concentrations in various foods by coupling the output of the atmospheric transport models with the food chain models.

VIII.1.3.1. SUJB approach

To obtain the dose as a function of distance, a spreadsheet file has been used. This approach is based on the SUJB Recommendation (2000) [70]. This procedure calculates the effective dose due to radionuclides released from stacks.

Atmospheric concentrations are estimated using a Gaussian plume model in similar way as the COMPLY code, taking into account the limitations of the model. Radionuclide concentrations in various foods are calculated by coupling the output of the atmospheric transport models with the food chain models.

The resulting output table contains the total effective dose as well as effective doses from external and internal exposure as a function of the distance from the stack.

The results at a distance of 2.5 km are shown in Table VIII.3.

Table VIII.3. Results of the SUJB calculations at a distance of 2.5 km.

Dose (mSv/a) at distance 2.5 km	SUJB	COMPLY(L2)	COMPLY(L4)
Ingestion	1.2	Not available	Not available
Inhalation	0.37	Not available	Not available
External	0.45	Not available	Not available
Radon	Not calculated	Not calculated	Not calculated
Total	2.0	2.4	0.88

The doses obtained from the SUJB calculation as a function of distance are presented in Figure VIII.11.

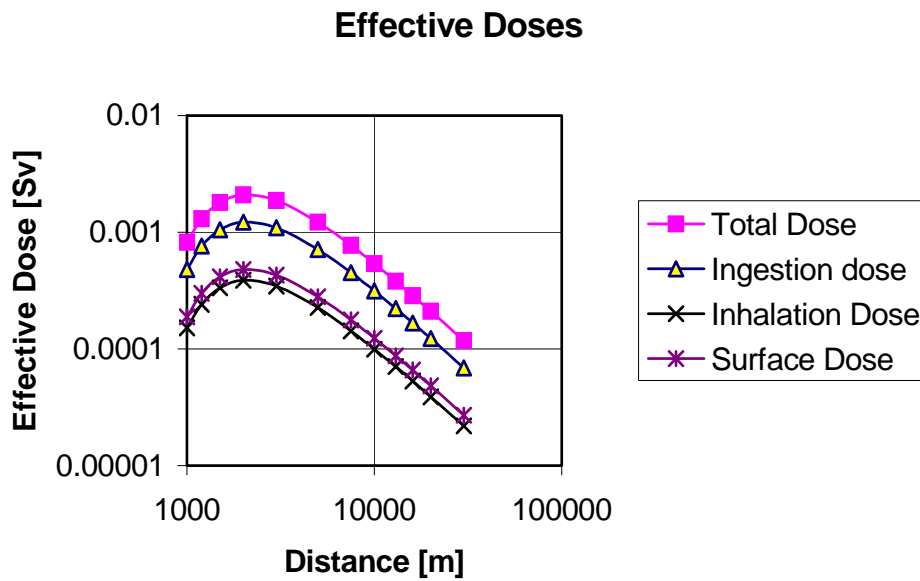

Fig. VIII.11. Doses as a function of distance, calculated using the SUJB approach.

VIII.1.4. CROM calculations

Only calculation for U238

Wet and Dry Deposition 500 m/d

Only Category D in Pasquill Gifford Scale

Means Velocity of 1.7 m/s

The mean height of the stack 130 m

Considering a homogeneous wind rose in 12 sector the fraction of time to receptor points is 0.083

Emission $1.7 \cdot 10^3$ Bq/s considering the 2 plant as only one emission point

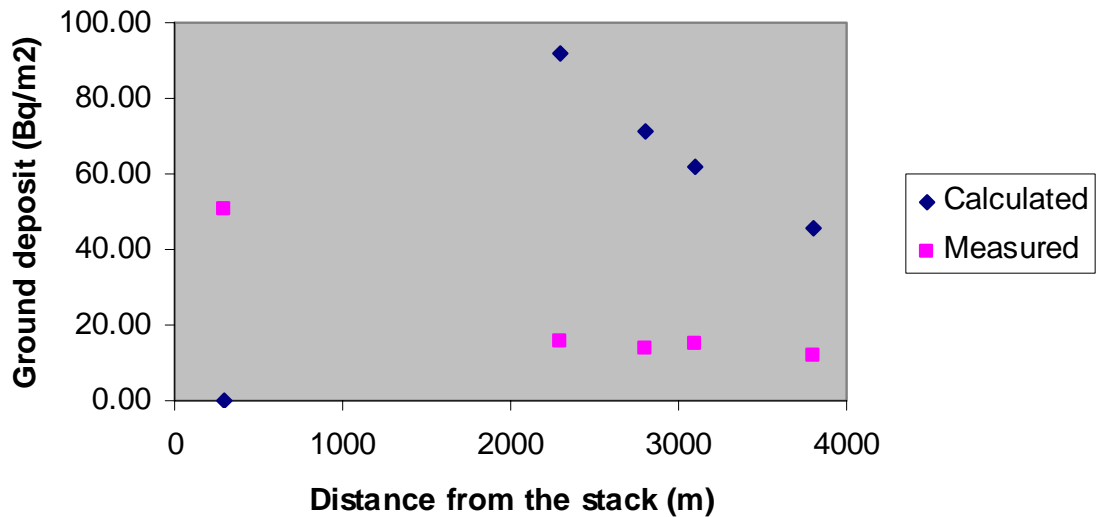

Fig. VIII.12. A comparison of measured and calculated ^{238}U ground deposition concentrations as a function of distance from the stack

For point M5, which is approximately 300 m from the stack, the concentration cannot be calculated using CROM with the assumptions given earlier. This is because this sampling point is inside the plant boundary, and there are other pathways that have not been included in the model.

The discrepancy between predicted and measured ground surface concentrations needs further investigation. One possibility is uncertainty in the magnitude of the source term. Another is that detailed wind-rose data and values for the wet and dry deposition coefficients were not available. However, given these deficiencies, the agreement between predicted and measured values is reasonable.

APPENDIX IX. DEVELOPMENT OF LOOKUP TABLES AND GRAPHS TO EVALUATE GENERIC RADIATION RISKS

The U.S. Environmental Protection Agency (EPA) conducted extensive data collection and risk assessment studies associated with human exposures to uranium mine (not milling) residues, primarily from legacy mine sites in the western part of the country. Utilizing the information collected, the Agency looked to two different models to conduct generic, rather than site specific, risk and dose assessments for what it considered the most likely human exposure scenarios to this type of NORM residues at smaller abandoned uranium mines: on-site recreation, homes with contaminated building materials, on-site residents, and near-by residents. This information supplements work previously conducted by EPA.

The purpose of this evaluation was to inform policy decisions for future efforts with affected governmental, tribal, and public stakeholders. One result of the study was development of a series of lookup tables and graphs of the calculations made. The tables and graphs enable a decision-maker to quickly assess the potential hazard associated with a particular exposure situation, and how that hazard varies according to time of exposure and radionuclide concentration involved. The discussion which follows is derived principally from one of the EPA reports [69], and includes two examples of developing lookup tables and graphs from the modelling results.

IX.1. On-Site Recreation

This scenario examined recreational use of a legacy uranium mine site, in which the abandoned mine is visited occasionally by hikers, campers, or driven through by all-terrain vehicles (ATVs). Recreational use by children may occur if a site is located near houses. Users would likely visit unreclaimed uranium mines for short periods of time, such as two weeks. Occupational workers, such as government employees or contractors performing site investigations, could also spend similar periods of time at these locations. The primary exposure pathways would be external exposure and drinking contaminated water from an adjacent spring or stream. Pathways of secondary importance include inhalation of dust, exposure to radon, ingestion of dust on dried or prepared foods, and inadvertent ingestion of soil. Calculations were made for both individual pathways and combined pathways.

Since the intent of this analysis was meant to be scoping in nature, the EPA Soil Screen Guidance (SSG) model was considered appropriate for identifying the magnitude of radiation hazard faced in the recreational scenario. As the intent of the SSG is to ensure that potential problems are identified, the SSG methodology tends to lead to conservative risk estimates, or risks that are more likely to be overestimated. The risk estimates become more accurate with more site-specific data.

Using the conservative SSG for radionuclides methodology, estimates were made of lifetime cancer risk for different exposure time periods and different concentrations for NORM radionuclides. For the discussion here, only the results for natural ^{226}Ra in secular equilibrium are presented.

The SSG methodology assumes a linear relationship between a person's incremental cancer risk from exposure to ^{226}Ra , ^{232}Th , and natural uranium ($^{238}\text{U} + ^{235}\text{U}$). In the U.S., the incremental lifetime cancer risk level of 10^{-6} is usually the baseline level of risk that is acceptable, and 5×10^{-4} is typically at the high end of the range of acceptability. Thus the Soil Screening Levels (SSLs) are evaluated for this range.

Due to the nature of the recreational scenario, it was assumed that the person spends the entire day at the site, with no indoor time—that is, the individual spends all day on the waste material and sleeps in a tent or other light structure that provides no appreciable shielding. Since no time is spent indoors, gamma shielding does not come into play. For a target risk of 1×10^{-6} for 14 days of exposure and the assumptions stated above, the ^{226}Ra soil screening level would be $\sim 114 \text{ Bq kg}^{-1}$, but for one day of exposure at a target risk of 1×10^{-6} , the ^{226}Ra soil screening level would be $\sim 1590 \text{ Bq kg}^{-1}$). Table IX.1 and Figure IX.1 illustrate the relationship between radium concentration and risk for different times of exposure. The relationship is linear, so reducing the estimated time on site by one half (from 100 percent of the time on site to 50 percent) would increase the radium screening level by a factor of two for the same target risk. The risk estimated for a recreational exposure could also be used for occupational workers (government workers or contractors for example) who spent time at the site for their jobs.

Table IX.1. Soil Screening Levels for external exposure to ^{226}Ra .

Exposure Frequency (days)	Target Cancer Risk					
	5×10^{-4}	1×10^{-4}	5×10^{-5}	1×10^{-5}	5×10^{-6}	1×10^{-6}
	Concentration of ^{226}Ra (Bq kg^{-1})					
1	794,950	158,990	79,500	15,900	7,950	1590
14	56,780	11,360	5,680	1140	570	110
30	26,500	5300	2650	530	270	50
52	15,290	3060	1530	310	150	30
140	5680	1140	570	110	60	10
350	2280	450	230	50	20	5

Table IX.1 lists the data used to generate Figure IX.1.

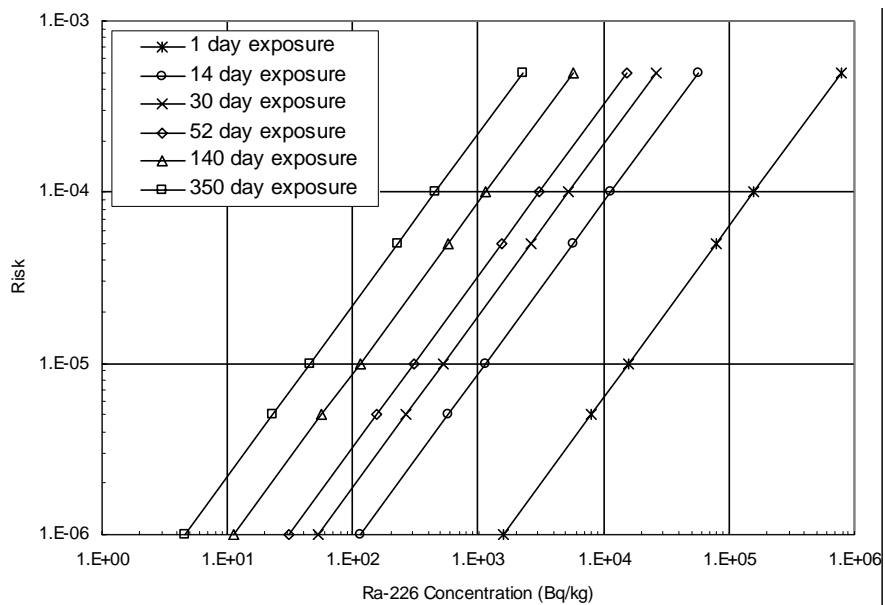

Fig. IX.1. External exposure—relationship between exposure frequency, radium concentration and target lifetime cancer risk.

In Figure IX.1 the x-axis is the activity concentration of radium in the uranium mine waste material, and the y-axis is the incremental lifetime cancer risk as a result of direct exposure to the radium in the waste material for different time periods. For example, exposure to 454 Bq kg⁻¹ of radium, in secular equilibrium with its progeny, for 350 days, would result in a lifetime cancer risk of 10⁻⁴.

Similar calculations and graphs were developed in the study using the separate calculation modules of the SSG for soil ingestion, as well as inhalation of fugitive dusts, and drinking contaminated water at the site. The results of combining the calculations made for all pathways are shown below in Table IX.2 and Figure IX.2.

Table IX.2. Multi-pathway Soil Screening Levels for ²²⁶Ra.

Exposure Frequency (days/year)	Target Cancer Risk					
	5×10 ⁻⁴	1×10 ⁻⁴	5×10 ⁻⁵	1×10 ⁻⁵	5×10 ⁻⁶	1×10 ⁻⁶
	Concentration of ²²⁶ Ra (Bq kg ⁻¹)					
1	781,300	156,250	78,130	15,630	7810	1560
14	55,800	11,160	5580	1110	560	110
30	26,000	5210	2600	520	260	50
52	15,030	3000	1500	300	150	30
140	5580	1120	560	110	60	10
350	2230	450	220	50	20	5

Exposure Frequency (days/year)	Target Cancer Risk					
	5×10 ⁻⁴	1×10 ⁻⁴	5×10 ⁻⁵	1×10 ⁻⁵	5×10 ⁻⁶	1×10 ⁻⁶
	Concentration of ²²⁶ Ra (Bq kg ⁻¹)					
1	781,300	156,250	78,130	15,630	7810	1560
14	55,800	11,160	5580	1110	560	110
30	26,000	5210	2600	520	260	50
52	15,030	3000	1500	300	150	30
140	5580	1120	560	110	60	10
350	2230	450	220	50	20	5

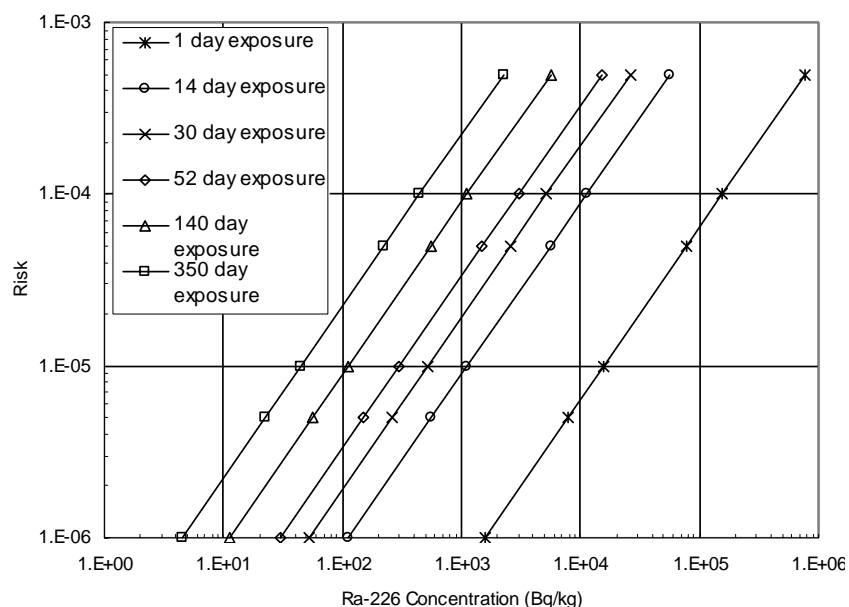

Fig. IX.2. Multi-pathway Soil Screening Graphs for ²²⁶Ra.

In Figure IX.2 the x-axis is the activity concentration of radium in the uranium mine waste material, and the y-axis is the incremental lifetime cancer risk as a result of exposure to the radium in the waste material for different time periods. The graphs portray combined risks via multiple pathways (direct exposure, inhalation, and ingestion) to soil radium.

IX.2. Use of Uranium Mine Waste in Building Materials

Given that some homes incorporate uranium mine waste building material, the question arises as to the radium and uranium concentrations in these materials that would result in exposure levels of concern. To identify potential gamma and radon exposures over a range of uranium and radium concentrations from contaminated concrete used as building materials for the floor and each wall, EPA used the Environmental Impact Assessment model RESRAD-BUILD 3.21 computer code. Only the radium concentration results are included in this appendix.

The building used for modelling was based on a concrete Navajo ceremonial house for which measurements had been made. The building modelled had one room with a floor area of $5\text{ m} \times 5\text{ m}$ or 25 m^2 . Each wall is assumed to be 2.5 m high and 5 m long, with an area of 12.5 m^2 (Figure IX.3). Occupancy is assumed to be 70 percent for 365 days a year. Since the calculations were scoping in nature, the RESRAD-BUILD default parameters were used. It was assumed that the floors and walls were made of concrete, the radium and uranium concentrations were equal, and the receptor was at a height of 1 m . However, RESRAD-BUILD calculates the contribution of the floor and the wall, so that the contribution from each part can be separated. The calculations assume no contribution from the soil beneath the concrete floor. The concrete was assumed to be 15 cm thick, with a density of 2.4 g cm^{-3} . Doses from direct exposure to radiation, calculated by RESRAD-BUILD, are presented in Table IX.3 and Figure IX.4.

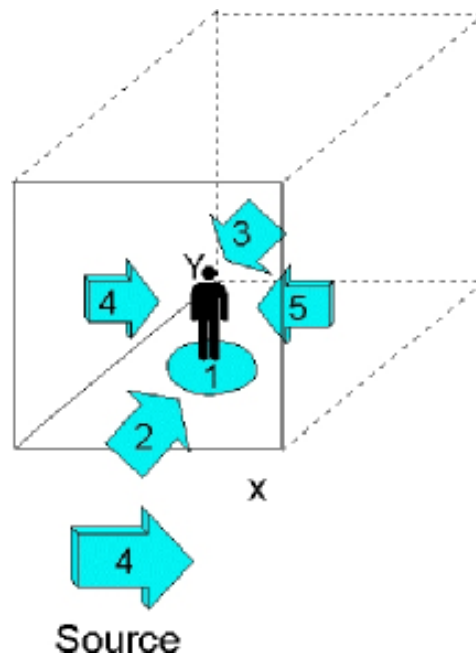

Fig. IX.3. Building Exposure Model.

This 3-D schematic of the building modelled indicates the sources of direct exposure with the floor as source 1, and the walls as sources 2 - 5. The origin of the geometry is at the lower left-hand corner, where z represents the vertical extent of the room and x and y represent the lateral extent of the walls.

Table IX.3. Doses from 30 years of external exposure to ^{226}Ra in the modelled building. The dose from the floor is about equal to all of the walls combined.

Activity Concentration (Bq kg^{-1})	Dose from floor (mSv)	Dose from one wall (mSv)
37	0.14	0.4
370	14	4
740	28	8

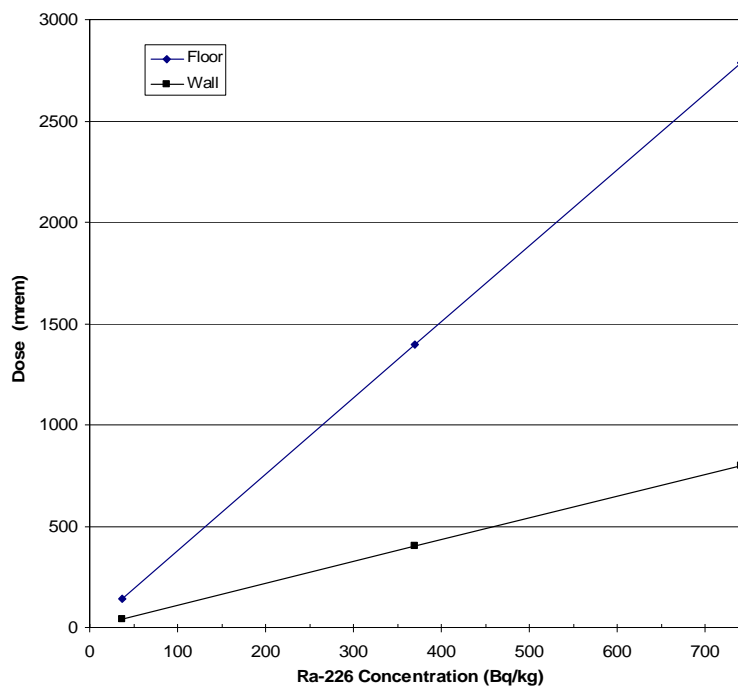

Fig. IX.4. Doses from 30 years of external exposure to ^{226}Ra in the modelled building.

Although ^{238}U would contribute to the overall radiation exposure, the ^{226}Ra in the mining waste materials is the more hazardous of the two radionuclides.

A concentration of 37 Bq kg^{-1} of ^{226}Ra in the floor is estimated to result in a dose of about 1.4 mSv during 30 years of external exposure. According to a 1985 EPA Report to Congress, most of the uranium mines sampled had ^{226}Ra concentrations of 740 Bq kg^{-1} or more in the waste. If waste with this radium activity were incorporated into a concrete floor slab, it would result in a 30-year dose of about 28 mSv. Figure IX.4 illustrates the relationship between ^{226}Ra concentrations and doses from external exposure calculated with RESRAD-BUILD. In addition to direct external radiation exposure, radon generation from radioactive decay could also contribute to risk posed by living in buildings constructed with uranium mine waste, depending on frequency of air exchange and other factors. The radon contribution to dose was not computed here.

REFERENCES

- [1] INTERNATIONAL ATOMIC ENERGY AGENCY, Handbook of Parameter Values for the Prediction of Radionuclide Transfer in Temperate Environments, Technical Report Series No. 364, IAEA, Vienna (1994).
- [2] UNITED NATIONS SCIENTIFIC COMMITTEE ON THE EFFECTS OF ATOMIC RADIATION, Sources, effects and risks of ionising radiation, UNSCEAR Report to the General Assembly, with annexes, United Nations, New York (1994).
- [3] INTERNATIONAL ATOMIC ENERGY AGENCY, Application of the Concepts of Exclusion, Exemption and Clearance, Safety Guide No. RS-G-1.7, IAEA, Vienna (2004).
- [4] NATIONAL ACADEMY OF SCIENCES, Evaluation of Guidelines for Exposures to Technologically Enhanced Naturally Occurring Radioactive Materials, Washington, DC, National Academy Press (1999).
- [5] SWEDISH RADIATION PROTECTION INSTITUTE, Long term contaminant migration and impacts from uranium mill tailings, BIOMOVs II, Technical Report No. 4, SSI, Stockholm, Sweden (1995).
- [6] SWEDISH RADIATION PROTECTION INSTITUTE, Long term contaminant migration and impacts from uranium mill tailings, BIOMOVs II, Technical Report No. 5, SSI, Stockholm, Sweden (1996).
- [7] SWEDISH RADIATION PROTECTION INSTITUTE, Wash-off of Sr-90 and Cs-137 from Two Experimental Plots: Model Testing Using Chernobyl Data, BIOMOVs II, Technical Report No. 9, SSI, Stockholm, Sweden (1996).
- [8] SWEDISH RADIATION PROTECTION INSTITUTE, Assessment of the Consequences of the Radioactive Contamination of Aquatic Media and Biota: Model Testing Using Chernobyl Data, BIOMOVs II, Technical Report No. 10, SSI, Stockholm, Sweden (1996).
- [9] SWEDISH RADIATION PROTECTION INSTITUTE, Atmospheric Resuspension of Radionuclides: Model Testing Using Chernobyl Data, BIOMOVs II, Technical Report No. 11, SSI, Stockholm, Sweden (1996).
- [10] INTERNATIONAL ATOMIC ENERGY AGENCY, Validation of models using Chernobyl fallout data from the Central Bohemia region of the Czech Republic—Scenario CB, First Report of the VAMP Multiple Pathways Assessment Working Group, IAEA-TECDOC-795, IAEA, Vienna (1995).
- [11] INTERNATIONAL ATOMIC ENERGY AGENCY. Modelling of radionuclide interception and loss processes in vegetation and of transfer in semi-natural ecosystems, Second Report of the VAMP Terrestrial Working Group, IAEA-TECDOC-857, IAEA, Vienna (1996).
- [12] INTERNATIONAL ATOMIC ENERGY AGENCY, Validation of models using Chernobyl fallout data from southern Finland—Scenario S, Second Report of the VAMP Multiple Pathways Assessment Working Group, IAEA-TECDOC-904, IAEA, Vienna (1996).
- [13] INTERNATIONAL ATOMIC ENERGY AGENCY, Testing of environmental transfer models using data from the atmospheric release of Iodine-131 from the Hanford site, USA, in 1963, Report of the Dose Reconstruction Working Group of the Biosphere Modelling and Assessment (BIOMASS) Programme, Theme 2, IAEA-BIOMASS-2, IAEA, Vienna (2003).
- [14] INTERNATIONAL ATOMIC ENERGY AGENCY, Testing of environmental transfer models using Chernobyl fallout data from the Iput River catchment area, Bryansk Region, Russian Federation, Report of the Dose Reconstruction Working

- Group of the Biosphere Modelling and Assessment (BIOMASS) Programme, Theme 2, IAEA-BIOMASS-4, IAEA, Vienna (2003).
- [15] SWEDISH RADIATION PROTECTION INSTITUTE, Multiple Model Testing using Chernobyl Fallout Data of I-131 in Forage and Milk and Cs-137 in Forage, Milk, Beef and Grain (H. Köhler, S.-R. Peterson, and F.O. Hoffman, eds.), BIOMOVs (Biospheric Model Validation Study) Technical Report 13, Vol. I-II, Scenario A4, SSI, Stockholm, Sweden (1991).
- [16] INTERNATIONAL ATOMIC ENERGY AGENCY, Testing of environmental transfer models using data from the remediation of a radium extraction site, Report of the Remediation Assessment Working Group of the Biosphere Modelling and Assessment (BIOMASS) Programme, Theme 2, IAEA-BIOMASS-7, IAEA, Vienna (2004).
- [17] INTERNATIONAL ATOMIC ENERGY AGENCY, Model Testing Using Chernobyl Fallout Data from the Iput River Catchment Area, Bryansk Region, Russia: Scenario "Iput.", BIOMASS Theme 2, Environmental Releases, Dose Reconstruction Working Group, BIOMASS/T2DR/WD02 IAEA, Vienna (2000).
- [18] INTERNATIONAL ATOMIC ENERGY AGENCY, Model Testing Using Data on Iodine-131 Released from Hanford. BIOMASS Theme 2, Environmental Releases, Dose Reconstruction Working Group, BIOMASS/T2DR/WD01, IAEA, Vienna (1999).
- [19] UNITED NATIONS SCIENTIFIC COMMITTEE ON THE EFFECTS OF ATOMIC RADIATION. Sources, effects and risks of ionising radiation, UNSCEAR Report to the General Assembly, with annexes, United Nations, New York (1988).
- [20] UNITED NATIONS SCIENTIFIC COMMITTEE ON THE EFFECTS OF ATOMIC RADIATION, Sources, effects and risks of ionising radiation, UNSCEAR Report to the General Assembly, with annexes, United Nations, New York (2000).
- [21] INTERNATIONAL ATOMIC ENERGY AGENCY, Regulatory and management approaches for the control of environmental residues containing naturally occurring radioactive material (NORM), IAEA-TECDOC-1484, IAEA, Vienna (2006).
- [22] INTERNATIONAL ATOMIC ENERGY AGENCY, IAEA Safety Glossary: Terminology Used In Nuclear, Radiation, Radioactive Waste And Transport Safety, Version 2.0, IAEA, Vienna (2006).
- [23] UNITED STATES ENVIRONMENTAL PROTECTION AGENCY, User's Guide for the Comply Code, EPA 520/1-89-003. USEPA (1989).
<http://www.epa.gov/radiation/assessment/comply.html>
- [24] UNITED STATES ENVIRONMENTAL PROTECTION AGENCY, User's Guide for the CAP88-PC, EPA 402-B-92-01. USEPA (1992).
<http://www.epa.gov/radiation/assessment/CAP88/index.html>
- [25] SIMMONDS, J.R., LAWSON, G., MAYALL, A., Methodology for assessing the consequences of routine releases of radionuclides to the environment, EUR 15670, European Commission, Luxembourg (1995).
- [26] INTERNATIONAL ATOMIC ENERGY AGENCY, Generic Models for Use in Assessing the Impact of Discharges of Radioactive Substances to the Environment, IAEA Safety Report Series No. 19, IAEA, Vienna (2001).
- [27] YU, C., ZIELEN, A.J., CHENG, J.-J., LEPOIRE, D.J., GNANAPRAGASAM, E., KAMBOJ, S., ARNISH, J., WALLO, A. III, WILLIAMS, W.A., PETERSON, H., User's manual for RESRAD version 6. Environmental Assessment Division; Argonne National Laboratory, Argonne, Illinois 60439; July (2001).
- [28] YU, C., LOUREIRO, C., CHENG, J.-J., JONES, L.G., WANG, Y.Y., CHIA, Y.P., FAILLACE, E., Data Collection Handbook To Support Modelling Impacts Of

- Radioactive Material In Soil. Environmental Assessment and Information Sciences Division, Argonne National Laboratory, Argonne, Illinois, April (1993).
- [30] YU, C., GNANAPRAGASAM, E., BIWER, B.M., KAMBOJ, S., CHENG, J.-J., KLETT, T., LEPOIRE, D., ZIELEN, A.J., CHENG, S.Y., WILLIAMS, W.A., WALLO, A., DOMOTOR, S., MO, T., SCHWARTZMAN, A., User's Manual for RESRAD-OFFSITE Version 2, ANL/EVS/TM/07-1, DOE/HS-0005, NUREG/CR-6937. June (2007).
- [31] YU, C., GNANAPRAGASAM, E., CHENG, J.-J., BIWER, B., Benchmarking of RESRAD-OFFSITE: Transition from RESRAD (onsite) to RESRAD-OFFSITE and Comparison of the RESRAD-OFFSITE Predictions with Peer Codes, ANL/EVS/TM/06-3, DOE/EH-0708, May (2006).
- [32] UNITED STATES ENVIRONMENTAL PROTECTION AGENCY, Welsbach/General Gas Mantle Contamination Site, Camden, New Jersey: Remedial Investigation / Feasibility Study Report; Vol. I, Contract No. 68-W9-0051, January (1999).
- [33] UNITED STATES ENVIRONMENTAL PROTECTION AGENCY, Welsbach/General Gas Mantle Contamination Site, Camden, New Jersey: Remedial Investigation/Feasibility Study Report; Vol. II, Contract No. 68-W9-0051, January (1999).
- [34] INTERNATIONAL ATOMIC ENERGY AGENCY, The extent of environmental contamination by naturally occurring radioactive material (NORM) and technological options for mitigation, IAEA Technical Report Series No. 419, IAEA, Vienna (2003).
- [35] COOPER, M.B., CLARKE, P.C., ROBERTSON, W., MCPHARLIN, I.R., JEFFREY, I.R., An investigation of radionuclide uptake into food crops grown in soils treated with bauxite mining residues, J. Radioanal. Nucl. Chemistry, 194(2), 379-387 (1995).
- [36] INTERNATIONAL ATOMIC ENERGY AGENCY, Management of NORM Residues, Draft Safety Guide DS 352, Version 9, August (2006).
- [37] INTERNATIONAL ATOMIC ENERGY AGENCY, Radiation Protection and NORM Residue Management in the Zircon and Zirconia Industries, IAEA Safety Reports Series Draft only, IAEA, Vienna (2007).
- [38] INTERAGENCY STEERING COMMITTEE ON RADIATION SAFETY, ASSESSMENT OF RADIOACTIVITY IN SEWAGE SLUDGE: Radiological Survey Results and Analysis, EPA 832-R-03-002, November (2003).
- [39] INTERAGENCY STEERING COMMITTEE ON RADIATION SAFETY, Assessment of Radioactivity in Sewage Sludge: Modeling to Assess Radiation Doses, EPA 832-R-03-002A, February, 2005.
- [40] INTERAGENCY STEERING COMMITTEE ON RADIATION SAFETY, Assessment of Radioactivity in Sewage Sludge: Recommendations on Management of Radioactive Materials in Sewage Sludge and Ash at Publicly Owned Treatment Works, EPA 832-R-03-002B, February (2005).
- [41] [40 CFR 61.93\(a\), National Emission Standards for Hazardous Air Pollutants](#)
- [42] ECKERMAN, K.F., WOLBARST, A.B., RICHARDSON, A.C.B., Limiting Values of Radionuclide Intake and Air Concentration and Dose Conversion Factors for Inhalation, Submersion, and Ingestion, Federal Guidance Report No. 11, EPA-520/1-88-020, U.S. Environmental Protection Agency, Office of Radiation Programs, Washington, D.C. 20460 (1988).
- [43] ECKERMAN, K.F., RYMAN, J.C., External Exposure to Radionuclides in Air, Water, and Soil, Federal Guidance Report No. 12, EPA-402-R-93-081, U.S. Environmental Protection Agency, Office of Radiation and Indoor Air, Washington, D.C. 20460, September (1993).

- [44] INTERNATIONAL COMMISSION ON RADIOLOGICAL PROTECTION, Age-dependent Doses to the Members of the Public from Intake of Radionuclides, Part 5: Compilation of Ingestion and Inhalation Coefficients, ICRP Publication 72, Annals of the ICRP Vol. 26/1 (1996).
- [45] ECKERMAN, K.F., LEGGETT, R.W., NELSON, C.B., PUSKIN, J.S., RICHARDSON, A.C.B., Cancer Risk Coefficients for Environmental Exposure to Radionuclides, Federal Guidance Report No. 13, EPA-402-R-99-001, U.S. Environmental Protection Agency, Office of Radiation and Indoor Air, Washington, D.C. 20460, September (1999).
- [46] UNITED STATES ENVIRONMENTAL PROTECTION AGENCY, Risk Assessment, Radionuclide Table Slope Factors Download Area, U.S. Environmental Protection Agency, April 16 (2001). <http://www.epa.gov/radiation/heat/download.htm>
- [47] KRETZSCHMAR J.G., BOSMANS F., BULTYNCK H., COSEMANS G., DE BAERE G., MERTENS I., VANDERVEE, J., IFDM: the immission frequency distribution model – SCK•CEN (1977).
- [48] DEGRANGE, J-P., PENFOLD, J.S.S., MOBBS, S.F., Development of a methodology for assessing occupational exposure at workplaces where materials are processed which contain enhanced levels of natural radionuclides, Proceedings of International Symposium on radiological problems with natural radioactivity in the Non-Nuclear Industry, Amsterdam 8-10/10/1997.
- [49] INTERNATIONAL ATOMIC ENERGY AGENCY, Generic models for use in assessing the impact of discharges of radioactive substances to the environment, IAEA Safety Report Series No. 19, IAEA, Vienna (2001).
- [50] WATKINS, B.M., SMITH, G.M., LITTLE, R.H., KESSLER, J., A biosphere modelling methodology for dose assessments of the potential Yucca Mountain deep geological high level radioactive waste repository, Health Physics 76 (4), 355-367 (1999).
- [51] YU, C., LEPOIRE, D., GNANAPRAGASAM, E., ARNISH, J., KAMBOJ, S., BIWER, B.M., CHENG, J.-J., ZIELEN, A., CHEN, S.Y., Development of Probabilistic RESRAD 6.0 and RESRAD-BUILD 3.0 Computer Codes, Environmental Assessment Division; Argonne National Laboratory, Argonne, Illinois 60439; ANL/EAD/TM-98, NUREG/CR-6697, prepared for U.S. Nuclear Regulatory Commission, Washington, D.C. December (2000).
- [52] LEPOIRE, D., ARNISH, J., GNANAPRAGASAM, E., KAMBOJ, S., BIWER, B.M., CHENG, J.J., YU, C., CHEN, S.Y., Probabilistic Modules for the RESRAD and RESRAD-BUILD Computer Codes, User Guide. Environmental Assessment Division; Argonne National Laboratory, Argonne, Illinois 60439; ANL/EAD/TM-91, NUREG/CR-6692, prepared for U.S. Nuclear Regulatory Commission, Washington, D.C., November (2000).
- [53] KAMBOJ, S., LEPOIRE, D., GNANAPRAGASAM, E., BIWER, B.M., CHENG, J., ARNISH, J., YU, C., CHEN, S.Y., Probabilistic Dose Analysis Using Parameter Distributions Developed for RESRAD and RESRAD-BUILD Codes, Environmental Assessment Division, Argonne National Laboratory, Argonne, Illinois 60439; ANL/EAD/TM-89 NUREG/CR-6676, prepared for U.S. Nuclear Regulatory Commission, Washington, D.C., July, May (2000).
- [54] INTERNATIONAL COMMISSION ON RADIOLOGICAL PROTECTION, Radionuclide Transformations: Energy and Intensity Emissions, ICRP Publication 38, Annals of the ICRP, Vols. 11–13 (1993).
- [55] INTERNATIONAL COMMISSION ON RADIOLOGICAL PROTECTION, Age-dependent Doses to Members of the Public from Intake of Radionuclides, Part 1, ICRP Publication 56, Annals of the ICRP, Vol. 20/2 (1990).

- [56] INTERNATIONAL ATOMIC ENERGY AGENCY, Generic models for use in assessing the impact of discharges of radioactive substances to the environment. IAEA Safety Reports Series No. 19, IAEA, Vienna (2001).
http://www-pub.iaea.org/MTCD/publications/PDF/Pub1103_scr.pdf
- [57] Council Directive (1996) 96/29/Euratom of 13 May 1996 laying down the basic standards for the protection of the health workers and the general public against the dangers arising from ionising radiation, Official Journal of the European Commission L159 (29-06-96).
- [58] MARKKANEN, M., Radiation dose assessments for materials with elevated natural radioactivity, STUK-B-STO 32, Finnish Centre for Radiation and Nuclear Safety, Helsinki (1995).
- [59] U.S. ENVIRONMENTAL PROTECTION AGENCY, Soil Screening Guidance for Radionuclides: User's Guide, Office of Radiation and Indoor Air and Office of Solid Waste and Emergency Response, EPA 540-R-00-007, PB 2000 963307 (2000).
- [60] ISHERWOOD, D., Geoscience Data Base Handbook for Modelling a Nuclear Waste Repository, NUREG/CR-0912, collective vols. 1 and 2, U.S. Nuclear Regulatory Commission, January (1981).
- [61] MÜLLER, H., PRÖHL, G., Ecosys-87: a dynamic model for assessing radiological consequences of nuclear accidents. *Health Phys.* 64(3):232-252 (1993).
- [62] SIMUNEK, J., SEJNA M, VAN GENUCHTEN, M.TH., The HYDRUS-2D software package for simulating two-dimensional movement of water, heat, and multiple solutes in variably saturated media, Version 2.0. IGWMC – TPS - 53, International Ground Water Modelling Center, Colorado School of Mines, Golden, Colorado, 251pp (1999).
- [63] SIMUNEK, J., VAN GENUCHTEN, M.TH., SEJNA, M., The HYDRUS-1D Software Package for simulating the one-dimensional movement of water, heat and multiple solutes in variably-saturated media, Version 3.0, HYDRUS Software Series 1, Department of Environmental Sciences, University of California Riverside, Riverside, California, USA (2005).
- [64] BAES, C.F., SHARP, R.D., A proposal for estimation of soil leaching and leaching constants for use in assessment models, *J. Environ. Qual.*, 12: 17-28 (1983).
- [65] PAPAETHYMIOU, H., KRITIDIS, P., ANOUSIS, J., SARAFIDOU, J., Comparative assessment of natural radioactivity in fallout samples from Patras and Megalopolis, Greece, *Journal of Environmental Radioactivity*, 78: 249–265 (2005).
- [66] ROUNI, P.K., PETROPOULOS, N.P., ANAGNOSTAKIS, M.J., HINIS, E.P., SIMOPOULOS, S.E., Radioenvironmental survey of the Megalopolis lignite field basin, *The Science of the Total Environment*, 272: 261-272 (2001).
- [67] CLARKE, L. B., SLOSS, L. L., Trace Elements – Emissions from Coal Combustion and Gasification. IEA Coal Research, IEACR/49, London (1992).
- [68] BEM, H., WIECZORKOWSKI, P., Determination of the total alpha radioactivity of thorium and uranium radionuclides in fallout using α/β LSC 2001, International Conference on Advances in Liquid Scintillation Spectrometry, Karlsruhe, Germany, May 7–11, 2001, pp. 335–341 (2002).
- [69] U.S. ENVIRONMENTAL PROTECTION AGENCY, Technologically Enhanced Naturally Occurring Radioactive Materials from Uranium Mining, Volume II: Investigation of Potential Health, Geographic, and Environmental Issues of Abandoned Uranium Mines. EPA 402-R-05-007, Washington, DC (2007).
- [70] Procedures to Calculation of the Exposure of the Critical Group of Members of the Public due to Natural Radionuclides Released into the Environment“(in Czech).

BIBLIOGRAPHY

- Andel, P., Priban, V. (1996a) *Environmental restoration of uranium mines and mills in the Czech Republic*. In: IAEA 1996a, 113-136.
- Andel P. and Priban V. (1996b) *Planning for environmental restoration of the uranium industry in the Czech Republic*. In: IAEA 1996b, 81-96.
- Andel P. and Priban V. (1996c) *Technologies for and implementation of environmental restoration of the uranium industry in the Czech Republic*. In: IAEA 1996c, 121-138.
- Anderson, M.P., Woessner, W.W. (1992) *Applied groundwater modelling: simulation of flow and advective transport*. Academic Press Inc.
- ANDRA (1995) *Ervaring van ANDRA inzake sites besmet door radium*. Informatievergadering op het Ministerie van Economische zaken, 10 November, 1995.
- ANDRA (1996) *Ervaring van ANDRA inzake sites besmet door radium*. Informatievergadering te Parijs, 11 October 1996.
- ANDRA (1998) *Inventaire national des déchets radioactifs établi par l'observatoire de l'ANDRA*.
- Baetslé L.H. (1991) *Study of radionuclides contained in wastes produced by the phosphate industry and their impacts of the environment*. European Commission, Report EUR 13262.
- Baker, R. (1993) *Bauxite mining by Alcoa of Australia Ltd in Western Australia*. In *Australasian Mining and Metallurgy: The Sir Maurice Mawby Memorial Volume*. Eds. J.T. Woodcock and J.K. Hamilton. The Australasian Institute of Mining and Metallurgy: Melbourne, Australia. ISBN 0 949106 76 3. Second Edition: Vol. 1; 749-750.
- Barlow, T. (1993) *Overview of the Australasian aluminium industry*. In *Australasian Mining and Metallurgy: The Sir Maurice Mawby Memorial Volume*. Eds. J.T. Woodcock and J.K. Hamilton. The Australasian Institute of Mining and Metallurgy: Melbourne, Australia. ISBN 0 949106 76 3. Second Edition: Vol. 1; 745-748.
- Baxter, J.L. *Heavy mineral sands deposits of Western Australia*. Mineral Resources Bulletin 10. Perth, Western Australia: Geological Survey; 1977.
- Baxter, M.S. *Technologically enhanced radioactivity: an overview*. Journal of Environmental Radioactivity: 32:3-18, 1996.
- Baxter, M. S., MacKenzie, A.B., East, B.W., Scott, E.M. (1996) *Natural decay series radionuclides around a large metal refinery*. Journal of Environmental Radioactivity: **32**, 115-134.
- Bergström U. (1982) *BIOPATH: a computer code for calculation of the turnover of nuclides in the biosphere and the resulting doses to man. A basic description*. STUDEVIK/NK-82/261.BfS, Bundesamt für Strahlenschutz (1992) Radiologische Erfassung, Untersuchung und Bewertung bergbaulicher Atlanten - Abschlussbericht zum ersten Teilproject, BfS Schriften 8/92, BfS, Berlin.
- BfS, Bundesamt für Strahlenschutz (1992) Radiologische Erfassung, Untersuchung und Bewertung bergbaulicher Atlanten - Abschlussbericht zum ersten Teilproject, BfS Schriften 8/92, BfS, Berlin.
- BfS, Bundesamt für Strahlenschutz (1994) Radiologische Erfassung, Untersuchung und Bewertung bergbaulicher Atlanten - Abschlussbericht zu Teilproject 2: Altasten Bergbau, Verification (TP 2), BfS-IB-7, BfS, Berlin.

- Biesold H., Larue J., Ettenhuber E. and Röhnsch W. (1994) *Identification, verification and evaluation of radioactive contaminated sites in the Eastern part of Germany*. In: European Commission (1994), 923-927.
- BMWi - Bundesministerium für Wirtschaft (1993) WISMUT: Stand der Stilllegung und Sanierung. BMWi Dokumentation 335, Bonn.
- Brown, J., Simmonds, J.R. (1995) *FARMLAND: A Dynamic Model for the Transfer of Radionuclides Through Terrestrial Food Chains*. National Radiological Protection Board, Chilton: Technical Report NRPB-R273.
- Burnett, W.C., Schultz, M.K., Hull, C.D. *Radionuclide flow during the conversion of phosphogypsum to ammonium sulphate*. Journal of Environmental Radioactivity 32:33-52, 1996.
- Cancio, D., Gutierrez, J., Ruiz C., Sainz, A. (1994). *Radiological considerations related with the restoration of a phosphogypsum disposal site in Spain*. In: European Commission. (1994), 645-652.
- Chen, Q, Degrange, J-P., Gerchikov M.Y., Hillis Z.K., Lepicard S, Meijne E.I.M., Smith K.R., van Weers A. (2003). *Effluent and Dose Control from European Union NORM Industries - Assessment of Current Situation and Proposal for a Harmonised Community Approach - Volume 1: Main Report*. European Commission: Radiation Protection 135.
- Clifford, L. *Overview of the Australasian coal mining industry*. In: *Australian Mining and Metallurgy*. Editors, Woodcock, J.T., and Hamilton, J.K. The Australian Institute of Mining and Metallurgy, Clunies Ross House, 191 Royal Parade, Parkville, Victoria, Australia, 3052; 1993.
- Conference of Radiation Control Program Directors, Inc. *Regulation and Licensing of Technologically Enhanced Naturally Occurring Radioactive Materials (TENORM); Suggested State Regulations for Control of Regulation*. Vol. 1, Part N, Conference of Radiation Control Program Directors, Inc., Frankfort, Kentucky, October 1999.
- Cooper, M.B. *Naturally Occurring Radioactive Materials (NORM) in Australian Industries - Review of Current Inventories and Future Generation*. Report prepared for the Radiation Health and Safety Advisory Council, ERS-006, December 2003.
- Cooper, M.B., Clarke, P.C., Robertson, W., McPharlin, I.R., Jeffrey, R.C. (1995) *An investigation of radionuclide uptake into food crops grown in soils treated with bauxite-mining residues*. Journal of Radioanalytical and Nuclear Chemistry, Vol. 194, No. 2, 379-387.
- Cooper, M.B., Stanney, K.A., Williams, G.A. *An Investigation of the Speciation of Radionuclides in Sediments and Soils*. Technical Report ARL/TR039, ISSN 0157-1400, August 1981.
- Cooper, M.B., Statham, J.R., Williams, G.A. *Natural Radioactivity in the Production of Titanium Dioxide Pigment: A Study of the Laporte Plant and Environmental Behaviour of Radionuclides at Bunbury, Western Australia*. Technical Report ARL/TR037, ISSN 0157-1400, October 1981.
- Cottens, E., Vanmarcke, H., Loos, M., Slegers, W., Govaerts P., Vangelder, E., Declercq, H., Flemal, J.M., Avaux, J.L., Martens, R. (1994). *Contamination and possibilities for remediation in the vicinity of the former radium extraction plant in Olen. A case study*. In: European Commission (1994), 263-280.
- Crochon, Ph., Daroussin, J.L. (1996). *Remediation of the Ecarpière uranium tailing pond by COGEMA (France)*. In: IAEA 1996c, 139-152.

- CSA (1987) *Guidelines for Calculating Derived Release Limits for Radioactive Material in Airborne and Liquid Effluents for Normal Operation of Nuclear Facilities*. Toronto, Canadian Standards Association. Report No. CAN/CSA-N288.1-M287; 1987.
- Dahlgaard, H. (1996) *Polonium-210 in mussels and fish from the Baltic-North Sea estuary*. *Journal of Environmental Radioactivity*: **32**, 91-96.
- Daroussin, J.L., Pfiffelmann, J.P. (1996). *Milling sites remediation: Elements for a methodology as developed in France by COGEMA*. In: IAEA 1996b, 97-112.
- Deworm, J.P., Slegers, W., Gillard, J., Flemal, J.M., Culot J.P. (1988). *Survey of the natural radiation of the Belgian territory as determined by different methods*. *Radiation Protection Dosimetry*, **24**, 347-351.
- Dimitrov, M., Vapirev, E.I. (1996). *Uranium industry in Bulgaria and environment: Problems and specific features of the period of the technical close-out and the remediation of the negative consequences*. In: IAEA 1996b, 43-54.
- Dimitrov, M., Vapirev, E.I., Minev, L., Boshkova, T. (1996). *Uranium industry in Bulgaria and environment: Technologies and implementation of environmental restoration projects*. In: IAEA 1996c, 51-58.
- Dixon, D.W. (1984) *Hazard Assessment of Work with Ores Containing Elevated Levels of Natural Radioactivity*. NRPB-R143, National Radiological Protection Board, Didcot, pp17.
- Droppo, J.G. Buck, J.W. (1996) *Multimedia Environment Pollutant Assessment Systems (MEPAS): atmospheric pathway formulations*. PNNL 11080, Pacific Northwest National Laboratory, Richland, Washington.
- Drury, N.C. (1994). *Remediation and restoration of a radium and thorium contaminated site*. In: European Commission (1994)., 671-692.
- Dusar, M. (1996) Steenkool. In *Delfstoffen in Vlaanderen*; Gallents and Wouters (Eds.). Ministerie van de Vlaamse Gemeenschap, Dept EWBL. (in Dutch).
- Ehdwall, H. (1996). *A short review of Swedish uranium mining, milling and restoration in Randstad*. In: IAEA 1996a, 315-318.
- Eisenbud, M. *Environmental Radioactivity: from Natural, Industrial and Military Sources*. Academic Press, Inc. Third Edition, 1987.
- Ettenhuber, E. (1996). *Environmental restoration plans and activities in Germany*. Contribution to Regional Project on Environmental Restoration in Central and Eastern Europe, RER/9/022, Felix, Romania, 4-8 November 1996.
- Ettenhuber, E., Rönsch, W. (1996). *Identification and radiological characterisation of sites contaminated due to mining and milling: Methods and criteria applied in Germany*. In: IAEA 1996a, 143-150.
- Ettenhuber, E., Rönsch, W., Jurk, M. (1996). *Radiation exposure owing to contaminated due to mining and milling: Methods of dose estimations*. In: IAEA 1996b, 1113-120.
- European Commission (1994). *Proceedings of International Symposium on Remediation and Restoration of Radio-active Contaminated Sites in Europe*. Antwerp, 11-15 Oct., 1993. European Commission: Environment, Civil Protection and Nuclear Safety, Report XI-5027/94
- Eurostat (1995) *Basic Statistics*, 32nd Edition.

- Eylander, J.G.R., Lancée, P., Hartog, F.A., Jonkers, G., Frigo D.M. (1997). *Feasibility study: On-site decontamination of Dutch E&P site*. In: Proceedings of International Symposium on Radiological problems with natural radioactivity in the non-nuclear industry. European Commission - KEMA, Amsterdam, 8-10 September, 1997. 6.4
- Faussat, A., Fernique, J.C. (1994). *The French national inventory of radioactive waste*. In: European Commission (1994), 253-262.
- Faw, R.E., Shultis, J.K. *Radiological Assessment: Sources and Exposures*. PTR Prentice-Hall, Inc. Englewood Cliffs, New Jersey 07632; 1993.
- Ferry, C. (1995). GEOS V1.0: *Transfer of radionuclides through the geosphere from near-surface radioactive waste disposals*. IPSN/DPEI/SERGD/95/14.
- Freeze, R.A., Cherry, J.A. (1979). *Groundwater*. Prentice-Hall Inc.
- Ghilea, S., Coroianu, A., Fekete, F. (1994). *Environmental radioactive contamination caused by uranium ore mining in Romania*. In: European Commission (1994), 143-152.
- Gibbs, K.J., Radium contamination: *An overview of the U.K. Ministry of Defence experience*. In: European Commission (1994), 281-294.
- Goldammer, W., Barthel, R. (1994). *Site specific risk assessment and optimisation procedures applied to the remediation of uranium mining and milling sites in Germany*. In: European Commission (1994), 99-118.
- Gouma, J., Bhasin, A. (1993.) *Alumina production by Nabalco Pty Limited at Gove, NT*. In Australasian Mining and Metallurgy: The Sir Maurice Mawby Memorial Volume. Eds. J.T. Woodcock and J.K. Hamilton. The Australasian Institute of Mining and Metallurgy: Melbourne, Australia. ISBN 0 949106 76 3. Second Edition: Vol. 1; 763-766.
- Hartley, B.M., Hewson, G.S. *Contribution of regulatory programs to radiation risk reduction in the mineral sands industry*. Proceedings of the International Conference on Occupational Health and Safety in the Minerals Industry, Minesafe International 1990. Perth, Western Australia: Chamber of Mines and Energy; 1990, 255-268.
- Harvey, M.P., Hipkin, J., Simmonds, J.R., Mayall, A., Cagianca, T., Fayers, C., Haslam, I. (1994) *Radiological consequences of waste arising with enhanced natural radioactivity content from special metal and ceramic processes*. European Commission: Environment, Nuclear Safety and Civil Protection, Report EUR 15613.
- Hébert, J.P., Daroussin, J.L., Michel, P., Perih, Ch., Lozano Martinez, F., Lopéz Romero, A., Fietz, J., Langer, L., Kahn, A., Litvin, V., Nitsche, H. (1996) *Decommissioning of Old Uranium Ore Extraction and Treatment Installations*. European Commission: Science, Research and Development, report EUR 16885.
- Hedvall. R., Erlandsson, B. (1996) *Radioactivity concentrations in non-nuclear industries*. Journal of Environmental Radioactivity: **32**, 19-32.
- Henze, G. and Weiss, D. (1995). *Radiological impact on the environment due to mining and milling of uranium bearing hard coal in Central Germany (Freital Region, Saxony)*. In: Proceedings of an International Symposium on Environmental Impact on Radioactive Releases, IAEA, Vienna, 8-12 May 1995. IAEA-SM-339/45: 493-501.
- Hewson, G.S., Hartley, B.M. *Radiation research priorities in the mineral sands industry*. Journal of Radiological Protection 3:221-229, 1990.

Hinde, R.A., Mantarelli, D.M. (1993) *Bauxite mining by Worsley Alumina Pty Ltd at Boddington, WA*. In Australasian Mining and Metallurgy: The Sir Maurice Mawby Memorial Volume. Eds. J.T. Woodcock and J.K. Hamilton. The Australasian Institute of Mining and Metallurgy: Melbourne, Australia. ISBN 0 949106 76 3. Second Edition: Vol. 1; 745-748.

International Atomic Energy Agency. *Generic models and parameters for assessing the environmental transfer of radionuclides from routine releases: exposures of critical groups*. IAEA Basic Safety Series No. 57. International Atomic Energy Agency: Vienna, 1982.

International Atomic Energy Agency. *The environmental behaviour of radium. Vol. 2*. IAEA Technical Reports Series No. 310. International Atomic Energy Agency: Vienna, 1990.

International Atomic Energy Agency. *Effects of ionising radiation on plants and animals at levels implied by current radiation protection standards*. IAEA Technical Report Series No. 332. International Atomic Energy Agency: Vienna, 1992.

International Atomic Energy Agency. *Handbook of parameter values for the prediction of radionuclide transfer in temperate environments*. IAEA Basic Technical Report Series No. 364. International Atomic Energy Agency: Vienna, 1994.

International Atomic Energy Agency. *Clearance levels for radionuclides in solid materials: Application of exemption principles (Interim report for comment)*. IAEA-TECDOC-855. International Atomic Energy Agency: Vienna, January 1996.

International Atomic Energy Agency. *International Basic Safety Standards for Protection against Ionising Radiation and for the Safety of Radiation Sources*. IAEA Safety Series No. 115. International Atomic Energy Agency: Vienna, 1996.

International Atomic Energy Agency (1992). *Current Practices for the Management and Confinement of Uranium Mill Tailings*. IAEA, Vienna, Austria. pp 140.

International Atomic Energy Agency (1996a) *Planning for the environmental restoration of radioactively contaminated sites in central and Eastern Europe. Volume 1: Identification and characterisation of contaminated sites*. Proceedings of a workshop held within the Technical Co-operation Project on Environmental Restoration in Central and Eastern Europe in Budapest, Hungary, 4-8 October, 1993. IAEA-TECDOC-865; IAEA, Vienna.

International Atomic Energy Agency (1996b) *Planning for the environmental restoration of radioactively contaminated sites in central and Eastern Europe. Volume 2: Planning for the Environmental Restoration of Contaminated Sites*. Proceedings of a workshop held within the Technical Co-operation Project on Environmental Restoration in Central and Eastern Europe in Piestany, Slovakia, 11-15 April, 1994. IAEA-TECDOC-865; IAEA, Vienna.

International Atomic Energy Agency (1996c) *Planning for the environmental restoration of radioactively contaminated sites in central and Eastern Europe. Volume 3: Technologies for, and the Implementation of, Environmental Restoration of Contaminated Sites*. Proceedings of a workshop held within the Technical Co-operation Project on Environmental Restoration in Central and Eastern Europe in Rez, Czech Republic, 12-16 December, 1994. IAEA-TECDOC-865; IAEA, Vienna.

IMA/CIEMAT and Intera Information Technologies (1993) *Safety assessment comparison methodology for toxic and radioactive wastes, (SACO version 1.0)*. CIEMET/IMA/UCRE/10/93.

Juhasz L. and Erdi-Krausz G. (1996) *Consequences of the Hungarian uranium mining and milling*. In: IAEA 1996a, 151-156.

International Commission on Radiological Protection. *Recommendations of the International Commission on Radiological Protection*. Publication 26, Annals of the ICRP: 1(3), 1-53, 1977.

- International Commission on Radiological Protection. *Limits for intakes of radionuclides by workers*. Publication 30, Annals of the ICRP: 2(3/4), 1-116, 1979.
- International Commission on Radiological Protection. *1990 Recommendations of the International Commission on Radiological Protection: Users' Edition*. Pergamon Press, Oxford; 1992.
- International Commission on Radiological Protection. *Age-dependent doses to members of the public from intake of radionuclides: Part 2 - Ingestion dose coefficients*. Publication 67, Annals of the ICRP: 23(3-4), 1- 167, 1993.
- International Commission on Radiological Protection. *Human respiratory tract model for radiological protection*. Publication 66, Annals of the ICRP: 24(1-3), 1- 482, 1994.
- Jarvis, N.S., Birchall, A., James, A.C., Bailey, M.R., Dorrian, M-D. LUDEP 2.0: *Personal computer program for calculating internal doses using the ICRP Publication 66 respiratory tract model*. National Radiological Protection Board, Chilton: Technical Report NRPB-SR287, 1996.
- Juhasz, L., Erdi-Krausz, G. (1996). *Consequences of the Hungarian uranium mining and milling*. In: IAEA 1996a, 151-156.
- Juhasz, L., Kanyar, B., Fulop, N., Lendvai, Z.S., Csovari, M. (1996a). *Radiohygienic analysis of the radioactive contamination in the region of the uranium mining and milling*. In: IAEA 1996b, 121-134.
- Juhasz, L., Lendvai, Z.S., Csicsak, J. Csovari, M. (1996b). *The restoration work on the Hungarian uranium mining area*. In: IAEA 1996c, 121-134.
- Keating, G.E., McCartney, M., Davidson, C.M. (1996) *Investigation of the technological enhancement of natural decay series radionuclides by the manufacture of phosphates on the Cumbrian coast*. Journal of Environmental Radioactivity: **32**, 53-66.
- Kerrigan, G.C., O'Connor, B.H. *Evaluation of Thorium series disequilibrium in Western Australian monazite*. Health Physics 58:157-163, 1990.
- Krizman, M.J. (1996). *Planning for environmental restoration of contaminated sites in Slovenia*. In: IAEA 1996b, 197-218.
- Krizman, M.J., Logar, Z. (1996). *Technologies for and implementation of environmental restoration project in Slovenia*. In: IAEA 1996c, 225-236.
- Leach, V.A., Lokan, K.A., Martin, L.J., Wise, K.N., Solomon, S.B., O'Brien, R.S. *Measurement of Radiation Parameters in Open-Cut Mining Situations*. International Conference on Radiation Hazards in Mining: Control, Measurement, and Medical Aspects, Colorado School of Mines, Golden, Colorado, October 4-9, pp 465-470, 1981a.
- Leach, V.A., Solomon, S.B., O'Brien, R.S., Wise, K.N. *Atmospheric Dispersion of Radon Gas from Open-pit Uranium Mines*. Second Applied Physics Conference of the Australian Institute of Physics, Royal Melbourne Institute of Technology, December 1981, pp 476-481b.
- Logar, Z. (1996). *Identification and radiological characterisation of contaminated sites in Slovenia*. In: IAEA 1996a, 283-298.
- Lysebo, I., Strand, T. (1997). *NORM in oil production in Norway*. In: Proceedings of International Symposium on Radiological problems with natural radioactivity in the non-nuclear industry. European Commission - KEMA, Amsterdam, 8-10 September, 1997.

- McDonald, K.B., Mandla, R. (1993) *Bauxite mining and beneficiation by Comalco Aluminium Ltd at Weipa, Qld.* In Australasian Mining and Metallurgy: The Sir Maurice Mawby Memorial Volume. Eds. J.T. Woodcock and J.K. Hamilton. The Australasian Institute of Mining and Metallurgy: Melbourne, Australia. ISBN 0 949106 76 3. Second Edition: Vol. 1; 750-754.
- McDonald, P., Baxter, M.S., Scott, E.M. (1996) *Technological enhancement of natural radionuclides in the marine environment.* Journal of Environmental Radioactivity: **32**, 67-90.
- Manolopoulou, M., Papastefanou, C. (1992). *Behaviour of natural radionuclides in lignites and fly ashes.* Journal of Environmental Radioactivity **16**, 261-271.
- Markkanen, M., Annanmäki, M. (1994). *Guidance on building materials and industrial waste containing elevated levels of radionuclides.* In: European Commission (1994)., 223-232.
- Martin, A., Mead, S., Wade, B.O. (1996) *Materials containing natural radionuclides in enhanced concentrations.* B4-370/95/000387/mar/c3.
- Mayall, A. (1995) FARMLAND: *Transfer of radionuclides to fruit.* National Radiological Protection Board, Chilton: Technical Memorandum NRPB-M545.
- Milton M.L.L. (1991). *Radiation at Dalgety Bay.* NRPB Visit Report NRPB/VR/4/1488
- Moroney, J.R. *Pathway analysis concepts for radiological impact assessment.* Australian Radiation Laboratory Technical Report ARL/TR106, 1992. (Invited paper presented to the Workshop on the Land Application of Effluent Water from Uranium Mines in the Alligator Rivers Region, Jabiru, N.T., September 1991.
- Mustonen, R., Pennanen, M., Annanmäki M., Oksanen, E. (1997) *Enhanced Radioactivity of Building Materials.* For the European Commission, Contract No 96-ET-003 (draft final report).
- National Bureau of Standards. U.S. Department of Commerce. *Radon transport through and exhalation from building materials: A review and assessment.* Washington D.C.: NBS; Technical Note 1139; 1981.
- National Health and Medical Research Council. *Code of Practice for the Disposal of Radioactive Wastes by the User (1985).* Canberra, Australia: Australian Government Publishing Service; 1986.
- National Health and Medical Research Council. *Code of practice for the near-surface disposal of radioactive waste in Australia (1992).* Radiation Health Series No. 35. Canberra, Australia: Australian Government Publishing Service; 1993.
- Newchurch, F.N., Galloway, T.J., Moretto, K.E. G.R. (1993) *Alumina production by Worsley Alumina Pty Ltd at Worsley, WA.* In Australasian Mining and Metallurgy: The Sir Maurice Mawby Memorial Volume. Eds. J.T. Woodcock and J.K. Hamilton. The Australasian Institute of Mining and Metallurgy: Melbourne, Australia. ISBN 0 949106 76 3. Second Edition: Vol. 1; 769-772.
- NUKEM (1995). *Assessment of the radiological aspects of the extraction and the processing of metal ores and of coal combustion in Eastern Germany.* European Commission, contract no. ETNU-CT94-0124.
- Oak Ridge National Laboratory. *RSICC Computer Code Collection: RESRAD 5.82; Code System to Implement Residual Radioactive Material Guidelines.* ORNL/CCC-552, June 1998.

- O'Brien, R. S. *Estimates of committed effective dose and annual limit on intake for radioactive dusts using the new ICRP Respiratory tract model*. Presented at the 20th annual conference of the Australian Radiation Protection Society, Brisbane, September 12-16, 1995.
- O'Brien, R.S. *Radioactivity in building materials – effects on indoor radon concentrations and gamma doses*. ACPSEM Conference, Canberra, Australia, October 21-24, 1996.
- O'Brien, R.S. *Gamma doses from phospho-gypsum plaster-board*. Health Physics 72(1):92-96, 1997.
- O'Brien, R.S. *Dose Calculations for Intakes of Ore Dust*. Australian Radiation Laboratory Technical Report ARL/TR127, ISSN 0157-1400, August 1998.
- O'Brien, R.S. *Excretion Calculations for Radionuclide Chains*. Presented at the 24th annual conference of the Australasian Radiation Protection Society, Margaret River, Western Australia, August 23-27, 1999.
- O'Brien, R.S., Aral, H., Peggie, J.R. *Internal and gamma radiation doses from glazed ceramic tiles*. Health Phys. 75(6):630-639, 1998.
- O'Brien, R.S., Cooper, M.B. *Assessment of potential radiological risks associated with the long term management of NORM-contaminated wastes arising from ESSO's oil and gas operations in Victoria*. Contract report to ESSO Australia Ltd., March 2000.
- O'Brien, R.S., Peggie, J.R., Leith, I.S. *Estimates of Inhalation Doses Resulting from the Possible Use of Phospho-gypsum Plaster-board in Australian Homes*. Health Physics 68(4):561-570, 1995.
- O'Keeffe, F.D. (1993) *Bauxite mining by Nabalco Pty Limited at Gove, NT*. In Australasian Mining and Metallurgy: The Sir Maurice Mawby Memorial Volume. Eds. J.T. Woodcock and J.K. Hamilton. The Australasian Institute of Mining and Metallurgy: Melbourne, Australia. ISBN 0 949106 76 3. Second Edition: Vol. 1; 754-755.
- Onishi, Y., Serne, R.J., Arnold, E.M., Cowan, C.E., Thompson, F.L. *Critical Review: Radionuclide transport, sediment transport, and water quality mathematical modelling; and radionuclide adsorption/desorption mechanisms*. NUREG/CR-1322, PNL-2901; Pacific Northwest Laboratory, Richland, Washington, 1981.
- Papastefanou, C. (1996) *Radiological impact from atmospheric releases of Ra-226 from coal-fired power plants*. Journal of Environmental Radioactivity: **32**, 105-114.
- Papastefanou, C., Charalambous, S. (1979). *On the radioactivity of fly ashes from coal power plants*. Zeitung für Naturforschung, **34a**, 533-537
- Penfold J.S.S., Degrange J.-P., Mobbs S.F. and Schneider T. (1997). *Establishment of Reference Levels for Regulatory Control of Workplaces where Minerals are Processed which Contain Enhanced Levels of Naturally Occurring Radionuclides*. 95-ET-009.
- Pérez Estévez, C., Sanchez Delgado, M. (1996a). *Identification and radiological characterisation of contaminated sites in Spain: Andujar uranium mill site*. In: IAEA 1996a, 299-314.
- Pérez Estévez, C., Sanchez Delgado, M. (1996b). *Decommissioning plan for Andujar uranium mill facilities*. In: IAEA 1996b, 219-226.
- Piestrynski, A., Pieczonka, J., Mielniczuk, W., Chrusciel, E., Jodlowski P. (1996). *Effects of uranium mining on the contamination of some areas in Poland*. In: IAEA 1996a, 193-216.
- Putnik, H. (1996). *Identification and radiological characterisation of contaminated sites in Estonia*. In: IAEA 1996a, 137-142.

- Putnik, H., Ehdwall, H., Mustonen, R., Qvale, H., Nosov, V., Salonen, L., Sundblad, B. (1994). *The uranium depository at Sillamäe, Estonia*. In: European Commission (1994)., 131-142.
- Pruppers, M.J.M., Blaauboer, R.O., Janssen, M.P.M., van Tuinen, S.T., Stoop P., Leenhouts, H.P. (1997). *Radiological risks of non-nuclear industries in the Netherlands*. In: Proceedings of International Symposium on Radiological problems with natural radioactivity in the non-nuclear industry. European Commission - KEMA, Amsterdam, 8-10 September, 1997.
- Ravila, A., Holm, E. (1996) *Assessment of the radiation field from radioactive elements in a wood-ash-treated coniferous forest in southwest Sweden*. Journal of Environmental Radioactivity: **32**, 135-156.
- Robertson, D.E., Schilk, A.J., Abel, K.H., Lepel, E.A., Thomas, C.W., Pratt, S.L., Cooper, E.L., Hartwig, P., Killey, R.W.D. *Chemical speciation of radionuclides migrating in groundwaters*. Journal of radioanalytical and Nuclear Chemistry, 194(2), 237-252, 1995.
- Robles, B., Simón, I., Torres, C. (1993) *Desarrollo de un modelo dosimétrico para la evaluación del impacto radiológico por un sistema de almacenamiento de residuos radiactivos*. DOSCAL. CIEMET/IMA/UCRE/17/93.
- Rönsch, W. and Ettenhuber, E. (1994). *Relics of mining and milling in Eastern Germany and their radiological consequences*. In: European Commission (1994)., 119-129.
- Sakamoto, Y., Tanaka, S. (1990) *QAD-CGGP2 and G33-GP2: revised versions of QAD-CGGP and G33-GP*. JAERI-M 90-110, JAERI.
- Saler, A., Barisic, D., Vekic, B., Lulic, S. (1996). *Restoration of radioactively contaminated sites in the Republic of Croatia*. In: IAEA 1996a, 91-112.
- Sandru, P. (1996a). *Consideration on some radioactive areas in Romania: Potential subjects for environmental restoration*. IAEA 1996a, 217-230.
- Sandru, P. (1996b). *Planning for environmental restoration in Romania*. In: IAEA 1996b, 145-152.
- Sandru, P. (1996c). *Technology for restoration of contaminated sites: Review of available experience in the field of environmental restoration in Romania*. In: IAEA 1996c, 181-188.
- Santiago, J.L. (1994). *Remediation of inactive uranium mining and milling sites in Spain*. In: European Commission (1994), 541-562.
- Santucci, P. (1995) *Conceptual and mathematical modelling of the biosphere: ABRICOT version 2.0*. IPSN/DPEI/SERGD/95/04.
- Scholten, L.C. (1996) *Approaches of Regular Management of Large Volumes of Waste Containing Natural Radionuclides in Enhanced Concentrations*. ETNU-CT93-0105
- SENES Consultants Limited (1985) *A study to develop and demonstrate techniques for the probabilistic assessment of the long-term effects of uranium mill tailings in Canada - Phase II*. Research report prepared for the National Uranium Tailings Program, CANMET, EMR, under Supply and Services Canada Contract No. OSQ84-00207.
- SENES Consultants Limited (1986) *Probabilistic model development for the assessment of the long-term effects of uranium mill tailings in Canada - Phase III*. Research Report prepared for the National Tailings Program, CANMET, EMR, under Supply and Services Contract No. OSQ85-00182.

SENES Consultants Limited (1987) *Uranium tailings assessment program (UTAP 3): component model documentation*. Research paper prepared under the National Uranium Tailings Program, CANMET, EMR, under Supply and Services Contract No. 23317-6-1728/01 SQ.

Simmonds, J.R., Lawson, G., Mayall, A. (1995) *Radiation Protection: Methodology for assessing the radiological consequences of routine releases of radionuclides to the environment*. European Commission, Luxembourg: Report EUR 15760 EN.

Skiba, G.R. (1993) *Alumina production by Queensland Alumina Limited, at Gladstone, Qld*. In *Australasian Mining and Metallurgy: The Sir Maurice Mawby Memorial Volume*. Eds. J.T. Woodcock and J.K. Hamilton. The Australasian Institute of Mining and Metallurgy: Melbourne, Australia. ISBN 0 949106 76 3. Second Edition: Vol. 1; 766-768.

Streile, G. (1996) *Multimedia Environment Pollutant Assessment Systems (MEPAS): short-term release formulations*. PNNL 11248, Pacific Northwest National Laboratory, Richland, Washington.

Streng, D.L., Chamberlain, P.J. (1995) *Multimedia Environment Pollutant Assessment Systems (MEPAS): exposure pathway and human health impact assessment models*. PNNL 10523, Pacific Northwest National Laboratory, Richland, Washington.

Subasic, D., Schaller, A., Barisic, D., Lulic, S., Vekic, B., Kovac, J., Lokobauer, N., Marovic, C. (1996a) *Restoration of radioactively contaminated sites in the Republic of Croatia*. In: IAEA 1996b, 55-80.

Subasic, D., Schaller, A., Barisic, D., Lulic, S., Vekic, B., Kovac, J., Lokobauer, N., Marovic, C. (1996b) *Restoration of radioactively contaminated sites in the Republic of Croatia*. In: IAEA 1996c, 87-120.

Sundblad, B., Stiglund, Y. (1994) *The restoration of the uranium mine in Randstad, Sweden. Environmental impact, predictions and monitoring*. In: European Commission (1994), 563-578.

Sundblad, B. (1996). *Planning for the restoration of the closed-down uranium mine in Randstad, Sweden*. In: IAEA 1996b, 227-236.

Sundblad, B., Stiglund, Y. (1996). *Technologies for and implementation of environmental restoration of the uranium mine in Randstad, Sweden*. In: IAEA 1996c, 237-242.

Terry, K.W., Hewson, G.S. *Retention and excretion of thorium by mineral sands industry employees*. Minerals and Energy Research Institute of Western Australia; Report No. 117; 1993.

Testa C., Desideri D., Meli M.A., Roselli C., Bassignani A., Colombo G. and Fantoni R.F. (1994). *Radiation protection and radioactive scales in oil and gas production*. Health Physics, **67(1)**, 34-38.

Till, J.E., Meyer, H.R. (eds). *Radiological assessment: A textbook on environmental dose analysis*. U.S. Nuclear Regulatory Commission, Washington D.C. 20555, NRC FIN B0766, September 1983.

Timmermans, C.W.M., Van der Steen, J. (1996) *Environmental and occupational impacts of natural radioactivity from some non-nuclear industries in The Netherlands*. Journal of Environmental Radioactivity: **32**, 98-104.

United Nations Scientific Committee on the Effects of Atomic Radiation (UNSCEAR). *Sources, effects and risks of ionising radiation*. Report to the General Assembly, with annexes. United Nations, New York, 1982.

United States Environmental Protection Agency (1985). *Report to Congress on Wastes from the Extraction and Beneficiation of Metallic Ores, Phosphate Rock, Asbestos, Overburden from Uranium Mining, and Oil Shale*. EPA 530/S W-85-003.

United States Environmental Protection Agency (USEPA). (1987) PATHRAE-EPA: *A performance assessment code for the land disposal of radioactive wastes - documentation and user's manual*. Office of Radiation Programs, EPA 520/1-87-028.

United States Environmental Protection Agency. (1993) *Diffuse NORM wastes - waste characterization and preliminary risk assessment*. U.S. E.P.A., Washington D.C: Draft Report RAE-9232/1-2, Vol.1.

United States Environmental Protection Agency. (1987) PATHRAE-EPA: *A performance assessment code for the land disposal of radioactive wastes - documentation and user's manual*. Office of Radiation Programs, EPA 520/1-87-028.

United States Environmental Protection Agency (2007). *Technologically Enhanced Naturally Occurring Radioactive Materials from Uranium Mining, Volume I: Mining and Reclamation Background*. EPA-402-R-05-007.

Uranerzbergbau, (1997, Personal Communication) Ruhrmann G., Becker D., Braun R. and Bartz. S. *Preliminary results from inventory of uranium liabilities in Eastern Europe collected in frame of a PHARE-project*.

Vandenhove, H., Zeevaert, Th., Bousher, A., Jackson, D., Lambers B., Hedemann Jensen, P. (2000). *Investigation of a possible basis for a common approach with regard to the restoration of areas affected by lasting radiation exposure as a result of past or old practice or work activity - CARE*, Final report for EC-DG XI-project 96-ET-006. Radiation Protection 115, Luxembourg, Office for Official Publication by the European Communities, printed in Belgium. pp 238.

Van Weers, A.W., Pace, I., Strand, T., Lysebo, I., Watkins, S., Sterker, T., Meijne, E.I.M. (1996) *Current Practice of Dealing with Natural Radioactivity from Oil and Gas Production in EU Member States*. ETNU-CT94-0112, 1996.

Vapirev, E.I., Dimitrov, M., Minev, L., Boshkova, T., Pressyanov, D., Guelev, M.G. (1994). *Radioactive sites in Bulgaria contaminated with radium and uranium*. In: European Commission (1994)., 929-956.

Vapirev, E.I., Dimitrov, M., Minev, L., Boshkova, T., Pressyanov, D., Guelev, M.G. (1996). *Radioactively contaminated sites in Bulgaria*. In: IAEA 1996a, 43-64.

Vels, B., Ruhrmann, G. (1994). *The uranium industry in the former Eastern block countries- Present status and new challenges associated with remediation work*. In Waste Management, 94, Tucson, Arizona, Feb. 27- March 3, 45-49.

Vos, H.A., Williams, G.A., Cooper, M.B. *The Speciation of Radionuclides in Sediments and Soils. Part II. Studies with a Sequential Organic Extraction Procedure*. Technical Report ARL/TR058, ISSN 0157-1400, July 1983.

Watson, I.D., Taylor, R.K. *The development of separate radiation protection regulations for monazite production in Western Australia*. Radiation Protection in Australia 2:17-25, 1984.

Whelan, G., McDonald, J.P. (1996) *Multimedia Environment Pollutant Assessment Systems (MEPAS): Groundwater environment*. PNNL 10907, Pacific Northwest National Laboratory, Richland, Washington.

Wichterey, K. (1994) *The radiological impact of mining and smelting of copper ore in Central Germany (Mansfeld-region)*. In: European Commission (1994), 295-308.

- Wilson J. (1990) *Radiation at Dalgety Bay*. NRPB Visit Report NRPB/VR/4/1477
- Wilson, A.J., Scott, L.M. (1992) *Characterization of radioactive petroleum piping scale with an evaluation of subsequent land contamination*. Health Physics, **63**, 6, 681-685.
- Woodcock, J.T., Hamilton, J.K. (Editors). *Australasian Mining and Metallurgy: The Sir Maurice Mawby Memorial Volume. Second Edition (in two volumes)*. The Australasian Institute of Mining and Metallurgy. Monograph Series, Monograph No. 19. Melbourne, Australia, 1993.
- Yu, C., Gnanapragasam, E., Cheng, J.-J., Biwer, B. *Benchmarking of RESRAD-OFFSITE: Transition from RESRAD (onsite) to RESRAD-OFFSITE and Comparison of the RESRAD-OFFSITE Predictions with Peer Codes*, ANL/EVS/TM/06-3, DOE/EH-0708, May 2006.
- Yu, C., Gnanapragasam, E., Biwer, B.M., Kamboj, S., Cheng, J.-J., Klett, T., LePoire, D., Zielen, A.J., Cheng, S.Y., Williams, W.A., Wallo, A., Domotor, S., Mo, T., Schwartzman, A. *User's Manual for RESRAD-OFFSITE Version 2*. ANL/EVS/TM/07-1, DOE/HS-0005, NUREG/CR-6937. June 2007.
- Yuan, Y.C. (1989) *MILDOS-AREA: an enhanced version of MILDOS for large-area sources*. ANL/ES-161, Argonne National Laboratory, Argonne, Illinois.

LIST OF PARTICIPANTS

Al-Khayat, T.	Ministry of Science and Technology, Iraq
Al-Masri, M.	Atomic Energy Commission of Syria, Syria
Amado, V.	Autoridad Regulatoria Nuclear, Argentina
Birky, B.	Florida Institute of Phosphate Research, United States of America
Cancio, D.	Centro de Investigaciones Energeticas, Mediambientales y Tecnologicas, Spain
Canoba, A.	Autoridad Regulatoria Nuclear, Argentina
García-Tenorio, R.	University of Seville, Spain
Gehrcke, K.	Bundesamt für Strahlenschutz, Germany
Gerler, J.	Bundesamt für Strahlenschutz, Germany
Golovan, O.	Complexny Service, Ukraine
Guetat, P.	Commissariat à l'Energie Atomique, France
Harris, F.	International Atomic Energy Agency
Heling, R.	Nuclear Research and Consultancy Group, Netherlands
Hilton, J.	Aleff Group, United Kingdom
Horyna, J.	State Office for Nuclear Safety, Czech Republic
Ivanova, K.	National Centre of Radiobiology and Radiation Protection, Bulgaria
Koukoulidou, V.	Greek Atomic Energy Commission, Greece
Krizman, M.	Slovenian Nuclear Safety Administration, Slovenia
Magro, L.	Agency for Environmental Protection and Technical Services, Italy
McDonald, P.	Westlakes Scientific Consulting Limited, United Kingdom
Nitzsche, O.	Brenk Systemplanung GmbH, Germany
Nuccetelli, C.	Istituto Superiore di Sanita, Italy
O'Brien, R.	Australian Radiation Protection and Nuclear Safety Agency, Australia
Olyslaegers, G.	Studiezentrum für Kernenergie, Belgium
Organo, C.	Radiological Protection Institute of Ireland, Republic of Ireland
Paganini Fioratti, M.	Agency for Environmental Protection and Technical Services, Italy

Pérez-Sánchez, D.	Centro de Investigaciones Energeticas, Mediambientales y Tecnológicas, Spain
Periáñez, R.	University of Seville, Spain
Quintana, E.	Autoridad Regulatoria Nuclear, Argentina
Rudya, K.	International Chernobyl Centre, Ukraine
Servant-Perrier, A.	Institut de Radioprotection et de Sûreté Nucléaire, France
Setlow, L.	US Environmental Protection Agency, United States of America
Sitnikov, S.	Federal Nuclear and Rad. Safety Authority of Russia, Russian Federation
Torri, G.	Agency for Environmental Protection and Technical Services, Italy
Tsatsi, L.	National Nuclear Regulator, South Africa
Vandenhove, H.	Studiezentrum für Kernenergie, Belgium
Waggitt, P.	International Atomic Energy Agency
Yu, C.	Argonne National Laboratory, United States of America
Zeevaert, T. [†]	Studiezentrum für Kernenergie, Belgium
Zelmer, R.	Atomic Energy of Canada Limited, Canada

[†] Deceased.